

Test & Burn-In PGA Kit Sockets

Pin Grid Arrays

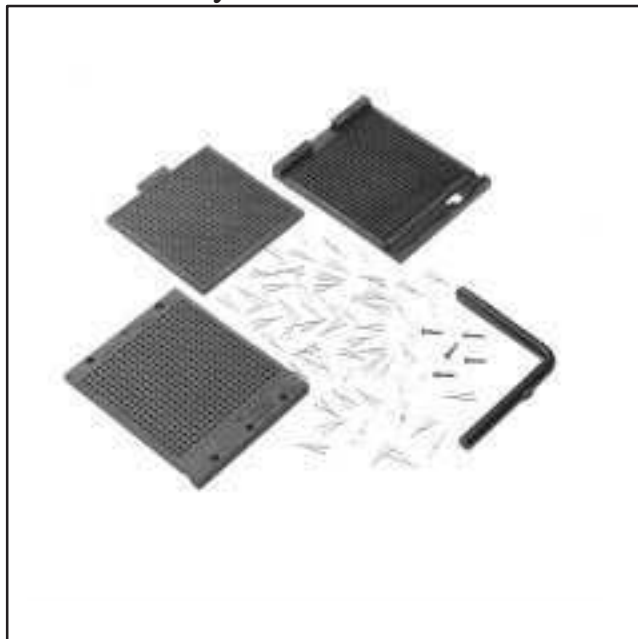

- Available in 10 x 10 matrix through 25 x 25 matrix
- Used when only a few test sockets are needed
- Provides individual components ready for assembly
- Open pattern top plate; load only those contacts needed for your specific device pin pattern

Date Issued: June 20, 2001

TS-0675-09
Sheet 1 of 2

10

Physical

Insulation

Material: Polyethersyfone (PES)
Flammability: UL 94V-0
Color: Black

Marking: 3M Logo & Part Number Identifier

Cam Handle

Material: Stainless Steel

Contact

Material: Beryllium Copper
Plating Options: 30 μ " (0.76 μ m) Gold over 50 μ " (1.3 μ m) Nickel

Electrical

Current Rating: 1 Amp
Insulation Resistance: $> 1 \times 10^{12} \Omega$ at 500 Vdc
Withstanding Voltage: 1000 Vrms at Sea Level

Environmental

Temperature Rating Operating: - 55°C to + 150°C

Mechanical

- A:** When used as a test socket at room temperature 24°C the socket will last 25,000 actuations.
- B:** Based on field experience, under normal burn-in conditions up to a maximum of 150°C, the socket should last an average of four years.

3M Electronic Handling and Protection Division

6801 River Place Blvd.
Austin, TX 78726-9000

For technical, sales or ordering information call **800-328-0411**
or visit our website: <http://www.3M.com/ehpd>

Test & Burn-In PGA Kit Socket

Pin Grid Arrays

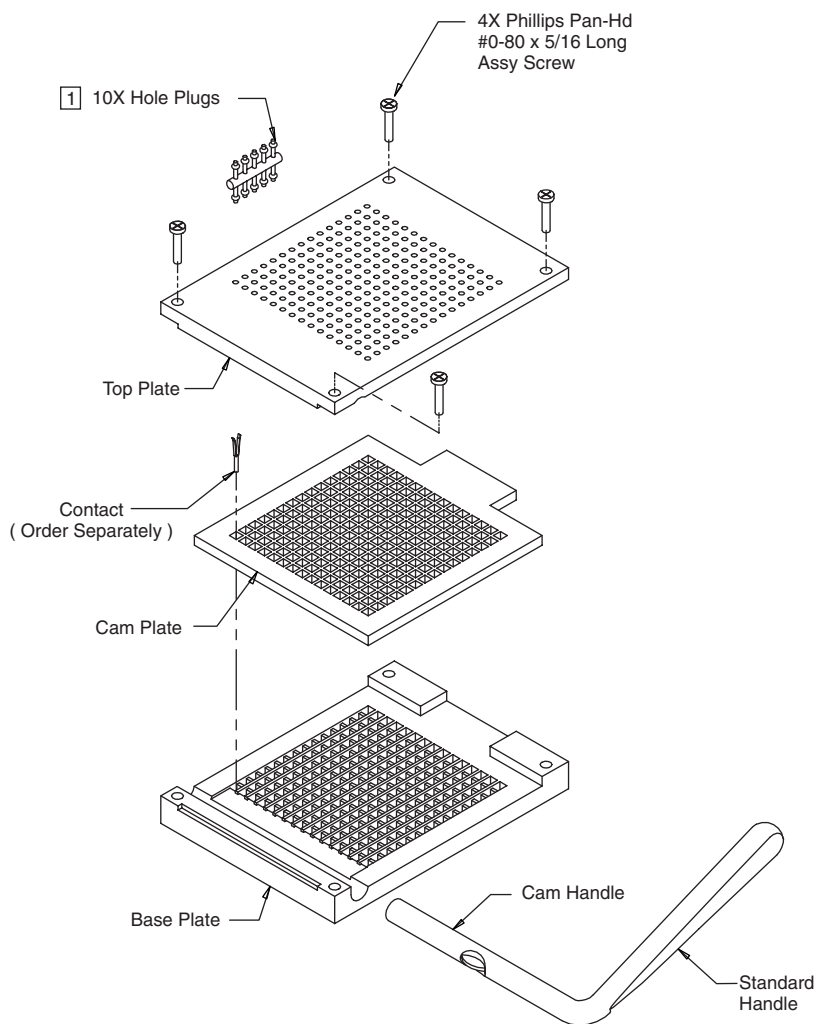

Assembly Instructions

1. Load hole plugs into top plate by pressing fitting into place. Remove from tie bar by cutting with commercially available 6 1/2" flush diagonal cutter pliers.
2. Place cam plate into recessed area of base plate, load contacts in desired locations, being careful that the bent leaf of the contact is loaded in correct position (away from cam handle.)
3. Insert cam handle into position in the base plate.
4. Now make a final check that all contacts are in desired location and that all are fairly even at the top. Also check cam to make sure it is still in position. Now take the top plate and place into position and start to lower over contacts. Start at the rear of the socket and rotate downward toward the front and then snap locating bosses into place. Several very slight back and forth motions may be necessary in order to get contacts to snap into place. Care should be taken that too much downward pressure isn't applied which could bend or damage the contacts. Insert screws and tighten.
5. Now make an operation check by rotating handle 90°. Make a visual check of movement and closure of all contacts. Rotate handle and check the freedom of movement of cam plate and that the moving leaf of the contact clears the entry hole. A continuity check can be made before final soldering by placing device in socket, then closing and making check. Soldering should be done with socket in the open position.

Notes:

- 1 Contact and extra Hole Plugs are ordered separately.
- 2 See Test & Burn-In PGA socket section on page 29 for dimensional information on assembled sockets.

Ordering Information

Part Number	Matrix Size	Description
200-6310-9UN-1900	10 x 10	Socket Kit W/O Contacts
200-6311-9UN-1900	11 x 11	
200-6313-9UN-1900	13 x 13	
200-6315-9UN-1900	15 x 15	
200-6317-9UN-1900	17 x 17	
200-6319-9UN-1900	19 x 19	
200-6321-9UN-1900	21 x 21	
200-6325-9UN-1900	25 x 25	
300-6300-CNA-0002B	Each	Contact-BeCu/Au Plated
200-4660-14-1900	Set of 10	Extra Hole Plugs

TS-0675-09
Sheet 2 of 2

3M Electronic Handling and Protection Division

6801 River Place Blvd.
Austin, TX 78726-9000

For technical, sales or ordering information call **800-328-0411**
or visit our website: <http://www.3M.com/ehpd>