

TOSHIBA TRANSISTOR SILICON NPN EPITAXIAL PLANAR TYPE (PCT PROCESS)

2SC2715

HIGH FREQUENCY AMPLIFIER APPLICATIONS.

Unit in mm

FEATURES :

- High Power Gain : $G_{pe} = 2\text{dB (Typ.) (}f = 10.7\text{MHz)}$
- Recommended for FM IF, OSC Stage and AM CONV. IF Stage.

MAXIMUM RATINGS (Ta = 25°C)

CHARACTERISTIC	SYMBOL	RATING	UNIT
Collector-Base Voltage	V_{CBO}	35	V
Collector-Emitter Voltage	V_{CEO}	30	V
Emitter-Base Voltage	V_{EBO}	4	V
Collector Current	I_C	50	mA
Base Current	I_B	10	mA
Collector Power Dissipation	P_C	150	wA
Junction Temperature	T_j	125	°C
Storage Temperature Range	T_{stg}	-55~125	°C

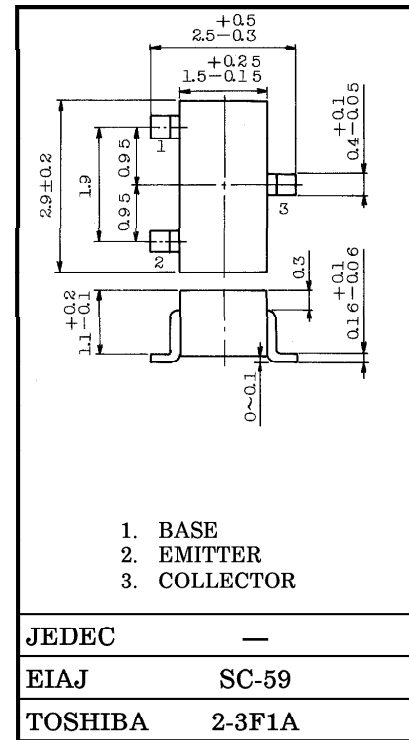

Weight : 0.012g

Marking

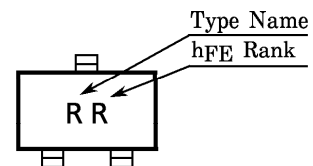

961001EAA2

● TOSHIBA is continually working to improve the quality and the reliability of its products. Nevertheless, semiconductor devices in general can malfunction or fail due to their inherent electrical sensitivity and vulnerability to physical stress. It is the responsibility of the buyer, when utilizing TOSHIBA products, to observe standards of safety, and to avoid situations in which a malfunction or failure of a TOSHIBA product could cause loss of human life, bodily injury or damage to property. In developing your designs, please ensure that TOSHIBA products are used within specified operating ranges as set forth in the most recent products specifications. Also, please keep in mind the precautions and conditions set forth in the TOSHIBA Semiconductor Reliability Handbook.

● The information contained herein is presented only as a guide for the applications of our products. No responsibility is assumed by TOSHIBA CORPORATION for any infringements of intellectual property or other rights of the third parties which may result from its use. No license is granted by implication or otherwise under any intellectual property or other rights of TOSHIBA CORPORATION or others.

● The information contained herein is subject to change without notice.

ELECTRICAL CHARACTERISTICS (Ta = 25°C)

CHARACTERISTIC	SYMBOL	TEST CONDITION	MIN.	TYP.	MAX.	UNIT
Collector Cut-off Current	I_{CBO}	$V_{CB} = 35V, I_E = 0$	—	—	0.1	μA
Emitter Cut-off Current	I_{EBO}	$V_{EB} = 4V, I_C = 0$	—	—	1.0	μA
DC Current Gain	h_{FE} (Note)	$V_{CE} = 12V, I_C = 2mA$	40	—	240	
Collector-Emitter Saturation Voltage	$V_{CE(sat)}$	$I_C = 10mA, I_B = 1mA$	—	—	0.4	V
Base-Emitter Voltage	V_{BE}	$I_C = 10mA, I_B = 1mA$	—	—	1.0	V
Transition Frequency	f_T	$V_{CE} = 10V, I_C = 1mA$	100	—	400	MHz
Collector Output Capacitance	C_{ob}	$V_{CB} = 10V, I_E = 0, f = 1MHz$	—	2.0	3.2	pF
Collector-Base Time Constant	$C_c \cdot r_{bb}'$	$V_{CE} = 10V, I_E = -1mA, f = 30MHz$	—	—	50	ps
Power Gain	G_{pe}	$V_{CC} = 6V, I_E = -1mA, f = 10.7MHz$ (Fig)	27	30	33	dB

Note : h_{FE} Classification R : 40~80, O : 70~140, Y : 120~240

y PARAMETER (Typ.)

(1) (COMMON EMITTER $f = 455MHz, T_a = 25^\circ C$)

CHARACTERISTIC	SYMBOL	2SC2715-R	2SC2715-O	2SC2715-Y	UNIT
Collector-Emitter Voltage	V_{CE}	6	6	6	V
Emitter Current	I_E	-1	-1	-1	mA
Input Conductance	g_{ie}	0.58	0.41	0.26	mS
Input Capacitance	C_{ie}	53	46	38	pF
Output Conductance	g_{oe}	1.9	2.7	4.8	μS
Output Capacitance	C_{oe}	2.6	2.8	3.6	pF
Forward Transfer Admittance	$ y_{fe} $	38	38	38	mS
Phase Angle of Forward Transfer Admittance	θ_{fe}	-0.79	-0.83	-0.92	°
Reverse Transfer Admittance	$ y_{re} $	5.7	5.7	6.2	μS
Phase Angle of Reverse Transfer Admittance	θ_{re}	-90	-90	-90	°

(2) (COMMON EMITTER $f = 10.7\text{MHz}$, $T_a = 25^\circ\text{C}$)

CHARACTERISTIC	SYMBOL	2SC2715-R	2SC2715-O	2SC2715-Y	UNIT
Collector Emitter Voltage	V_{CE}	6	6	6	V
Emitter Current	I_E	-1	-1	-1	mA
Input Conductance	g_{ie}	1.04	0.85	0.65	mS
Input Capacitance	C_{ie}	49	43	36	pF
Output Conductance	g_{oe}	10	15	28	μS
Output Capacitance	C_{oe}	2.7	2.9	3.6	pF
Forward Transfer Admittance	$ y_{fe} $	37	37	37	mS
Phase Angle of Forward Transfer Admittance	θ_{fe}	-9.6	-10.4	-11.5	$^\circ$
Reverse Transfer Admittance	$ y_{re} $	120	120	140	μS
Phase Angle of Reverse Transfer Admittance	θ_{re}	-90	-90	-90	$^\circ$

Fig. NF, G_{pe} TEST CIRCUIT

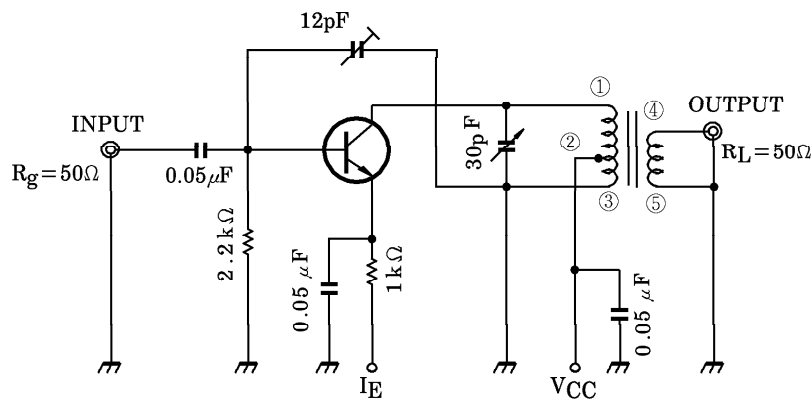

T : ①-② 0.1mm ϕ UEW 20T
 ②-③ 0.1mm ϕ UEW 8T
 ④-⑤ 0.1mm ϕ UEW 2T

