

AVX

A KYOCERA GROUP COMPANY

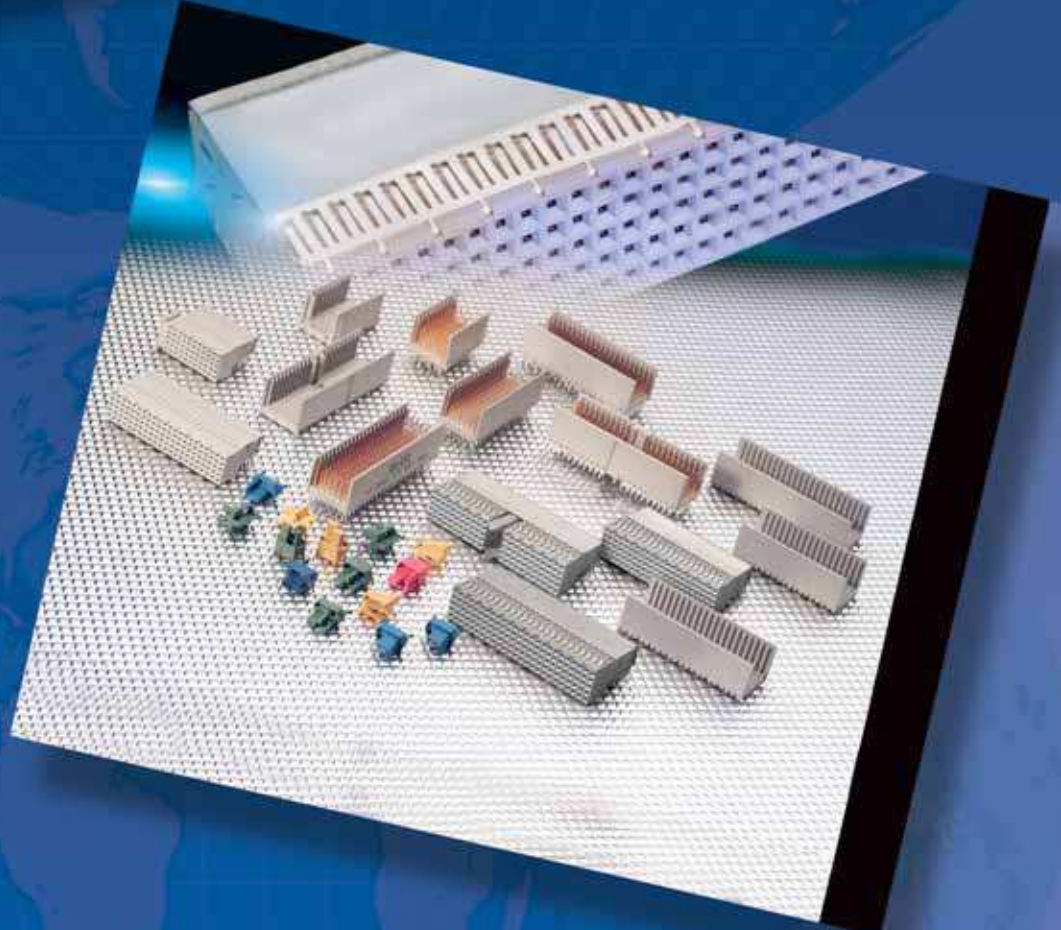

2mm Hard Metric Connectors

<Version 6.1>

Contents



Introduction	1	Vertical Male Style B 19, 133 Contacts, Series 7200	38
Technical Specifications	2	Vertical Male Style C 11, 77 Contacts, Series 7200	40
Multi-Line Module Connectors for CompactPCI® Series 7200	3	Type D Vertical Male for Backplanes, Series 8077	42
Sequential Mating and Contact Length Series 7200 – Types A, B, C	7	Type E Vertical Male for Backplanes, Series 8077	43
Part Number Format Male/Female	8	Type L Vertical Male for Backplanes, Series 8074	44
Right Angle Female, Series 7200 – Shield Types and Selection	9	Type M Vertical Male Feed-To for Backplanes, Series 8075	45
J1/J4 Right Angle Female Series 7200 – Style A 25, 110 Contacts	10	Type A Right Angle Male for Daughter Cards, Series 8072	46
J2/J5 Type B Right Angle Female, Series 7200	12	Type B Right Angle Male for Daughter Cards, Series 8072	47
Right Angle Female Style B 22, 110 Contacts	13	Type C Right Angle Male for Daughter Cards, Series 8072	48
J3 Right Angle Female Series 7200 – Style B 19, 95 Contacts	14	Press-fit Tools	49
Right Angle Female Series 7200 – Style B 25, 125 Contacts	16	Shroud, Type B for Midplane and Rear I/O Assemblies	50
Right Angle Female Series 7200 – Style C 11, 55 Contacts	18	Shroud, Type A and C for Midplane and Rear I/O Assemblies	51
J4 Type A Right Angle Female with Split Shield (Computer Telephony) Series 7200	20	Coding Keys Type A Male (Backplane) / Female (Daughter Card)	52
Right Angle Female with Split Shield (Computer Telephony)	21	High Power Contacts for L, M and N Connectors, Series 8489	54
Type D Right Angle Female for Daughter Cards, Series 8077	22	Coax Contacts for L and M Connectors, Series 8489	55
Type E Right Angle Female for Daughter Cards, Series 8077	23	Special Contacts for L, M and N Connectors	56
Type F Right Angle Female for Daughter Cards, Series 8077	24	Connectors Type A, B, C, 2mm Hard-Metric Custom Design Worksheet – Series 7200	57
Type AB Right Angle Female for Daughter Cards, Series 8071	25	Connectors Type D, E, F, 2mm Hard-Metric Custom Design Worksheet – Series 8075/8077	58
Type L Right Angle Female for Daughter Cards, Series 8074	27	Part Number Index	59
Type M Right Angle Female for Daughter Cards, Series 8075	28		
Type A Vertical Female for Backplanes, Series 8072	30		
Type B Vertical Female for Backplanes, Series 8072	31		
Vertical Male Style A 25, 154 Contacts, Series 7200	32		
Vertical Male Style B 25, 175 Contacts, Series 7200	34		
Vertical Male Style B 22, 154 Contacts, Series 7200	36		

NOTICE: Specifications are subject to change without notice. Contact your nearest AVX Sales Office for the latest specifications. All statements, information and data given herein are believed to be accurate and reliable, but are presented without guarantee, warranty, or responsibility of any kind, expressed or implied. Statements or suggestions concerning possible use of our products are made without representation or warranty that any such use is free of patent infringement and are not recommendations to infringe any patent. The user should not assume that all safety measures are indicated or that other measures may not be required. Specifications are typical and may not apply to all applications.

Connectors according to IEC 61076-4-101

The 2.0mm hard metric connectors made by AVX are developed and produced in accordance to the international engineering standards IEC 61076-4-101. Because of this users all over the world have a standard for the connection of printed circuit boards with high density connectors. The boards can be changed from one system to another without any problems. Important parameters like alignment, shielding and coding

remain compatible beyond the application. This specification has been selected as the CompactPCI® bus architecture by the PCI Industrial Computer Manufacturers Group (PICMG). AVX connectors have been specifically designed to fit in Position P1/P4, J1/J4 and P2/P5; J2/J5 for CompactPCI® applications and P0/J0 in the VME 64 extension format. AVX also offers full custom connector service to meet the specific needs of given markets and systems.

THE AVX ADVANTAGE

- Modular connector system with 2.0mm grid for CompactPCI® backplane and daughter cards.
- Insulators are beveled at each end to guarantee accurate positioning on the printed circuit board.
- Five, seven and eight signal rows plus two shield rows for optimum transmission performance.

CODING

To avoid mixing printed circuit boards Type A connectors use coding keys in accordance with IEC61076-4-101. Coding keys are inserted into the multi-function cavity by hand.

TYPE A MULTI-FUNCTION CAVITY & PRE-ALIGNMENT GUIDES

Type A connectors are equipped with a multi-function cavity and pre-alignment guides. The guides ensure proper alignment between the boards during mating. The cavity accepts coding keys in accordance with IEC61076-4-101 to prevent mis-mating of boards.

RoHs COMPLIANCE

The RoHs directive proposed by the European Commission imposes a ban on the following substances: lead, mercury, cadmium, hexavalent chromium, and PBB and PDBE's (halogenated flame retardants) The RoHs implementation Date is July 1, 2006.

AVX 2MM Hard Metric connectors are fully compliant with Directive 2002/95/EC and do not contain any of the substances Prohibited by RoHs for order entries after March, 1, 2006.

MODULAR SHIELDING

Modular shielding of female connectors enables high speed data transmission in high frequency application. Reduces the crosstalk level and allows an increase of the performance to subnanosecond pulse rise time if used in a differential pair application.

[12 different contact sizes for custom configurations](#)

AVX vertical male hard metric connectors have 3 different lengths at the mating side and 4 lengths at the terminal side. The different lengths are required for certain earliest make last break connections on signal or group contacts.

APPROVALS AND SPECIFICATIONS

AVX hard metric connector system meets the requirements of IEC 61076-4-101.

TELCORDIA (FORMERLY BELLCORE) GR-1217-CORE

AVX hard metric connectors are designed to meet the requirements of Telcordia Technologies (formerly BellCore), GR-1217-Core.

ISO9001

The complete hard metric connector system is manufactured in fully approved ISO9001 and QS9000 facilities.

PICMG®

The hard metric connector system meets the requirements of the CompactPCI® specification as defined by the PCI Industrial Computer Manufacturers Group.



PCI Industrial Computer Manufacturers Group, (PICMG), is a consortium of Industrial Computer Product vendors with the mission of designing specifications for PCI-based systems and boards to be used in industrial and telecommunications applications. For more information on PICMG visit their website at www.picmg.org

Multi-Line Module Connectors For CompactPCI®



TECHNICAL SPECIFICATIONS

Contact Spacing		2.0mm grid
Current Rating		1.0A/contact / 70°C
Voltage Rating		250V maximum
Dielectric Withstanding Voltage		750VAC rms/minute
Insulation Resistance	contact / contact	10 ⁴ M Ω minimum
	contact / shielding	10 ⁴ M Ω minimum
Contact Resistance		20m Ω maximum
Insertion Force	contact	n x 0.75 N maximum
	inclusive shielding	n x 1.00 N maximum
Separation Force	contact	n x 0.15 N minimum
	inclusive shielding	n x 0.15 N minimum
Operating Temperature		-55° to +125°C

MATERIAL

Contact	Plug	Phosphor Bronze
	Receptacle	Phosphor Bronze
Insulator	Plug	PBT 30% Glass Filled, UL 94V-0 Rated
	Receptacle	PBT 30% Glass Filled, UL 94V-0 Rated
Shroud		PBT 30% Glass Filled, UL 94V-0 Rated
Code Key		Glass Filled Polyester, UL 94V-0 Rated
Ground Return Shields		Phosphor Bronze



FINISH SERIES 7200

Finish Code		Class	Mating Cycle	Mating Area	Second Mating	Press-fit Area
001 / 004	male	1	>500	Au 1.27µm min.	Au 1.27µm min.	Ni 2-4µm min.
002 / 005	male	2	>250	Au 0.80µm min.	Au 0.80µm min.	Ni 2-4µm min.
001	female	1	>500	Au 1.27µm min.		Ni 2-4µm min.
002	female	2	>250	Au 0.80µm min.		Ni 2-4µm min.

FINISH SERIES 8071, 8072, 8077

Finish Code		Class	Mating Cycle	Mating Area	Other Area	Press-fit Area
833	male female	2	≥250	Pd/Ni 0.65µm min. Gold 0.1µm min.	Au 0.05µm	See individual page
863/517	male female	2	≥250	Au 0.76µm min.	Au 0.05µm	See individual page

COMPLIANT PINS

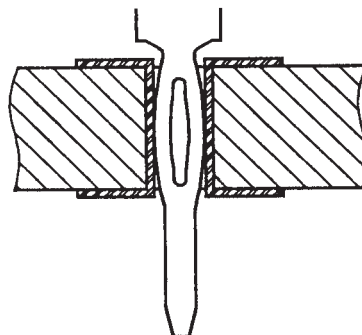

AVX Multi-Line Module Connectors utilize the original VARIPIN™ press-fit technology for reliable solderless applications.

Type D Right Angle Female for Daughter Cards

Series 8077

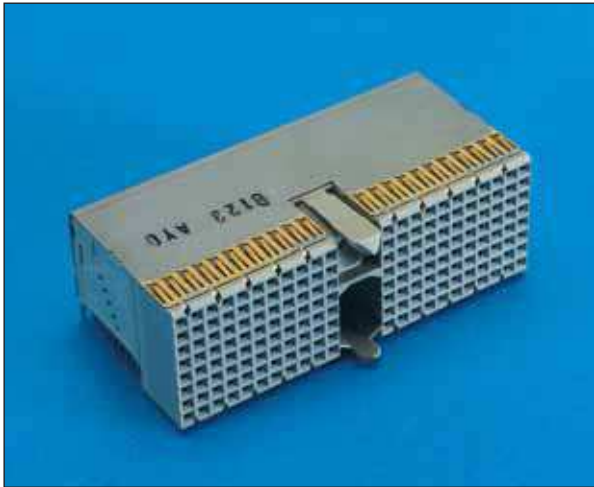

- 176 contacts in a 8 x 25 position configuration
- Center cavity with pre-alignment guides and keying option (uses 3 positions)
- See pages 52 and 53 for keying options
- Designed for gas tight press-fit installation
- Available with or without upper ground return shield
- This connector can be used by itself or in conjunction with Style E or F connectors



27 8077 176 001 863+ = Type D Right Angle Female without top shield

27 8077 176 011 863+ = Type D Right Angle Female with top shield

Plating Code	Contact Area	Press-fit Area	Under Coat
863	0.76µm min. Au	1.5-3.0µm Sn	1.2-3.0µm Ni

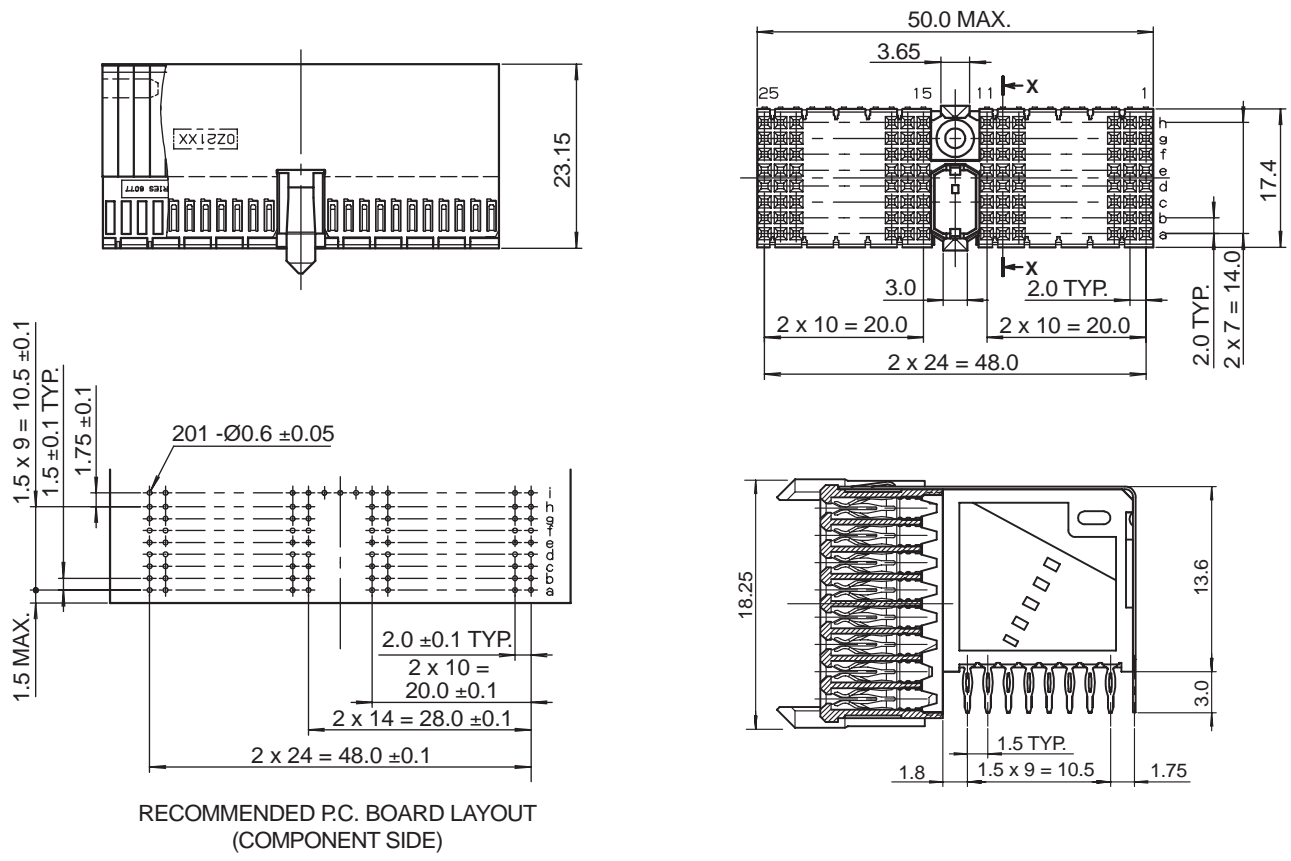

Type E Right Angle Female for Daughter Cards

Series 8077

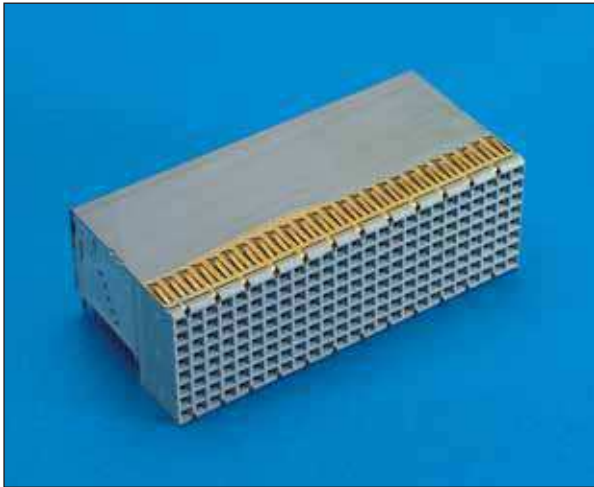

- 200 contacts in a 8 x 25 position configuration
- Designed for gas tight press-fit installation
- Available with or without upper ground return shield
- This connector should be used in conjunction with a Type D style to ensure proper mating alignment



27 8077 200 000 863+ = Type E Right Angle Female without top shield
27 8077 200 010 863+ = Type E Right Angle Female with top shield

Plating Code	Contact Area	Press-fit Area	Under Coat
863	0.76µm min. Au	1.5-3.0µm Sn	1.2-3.0µm Ni

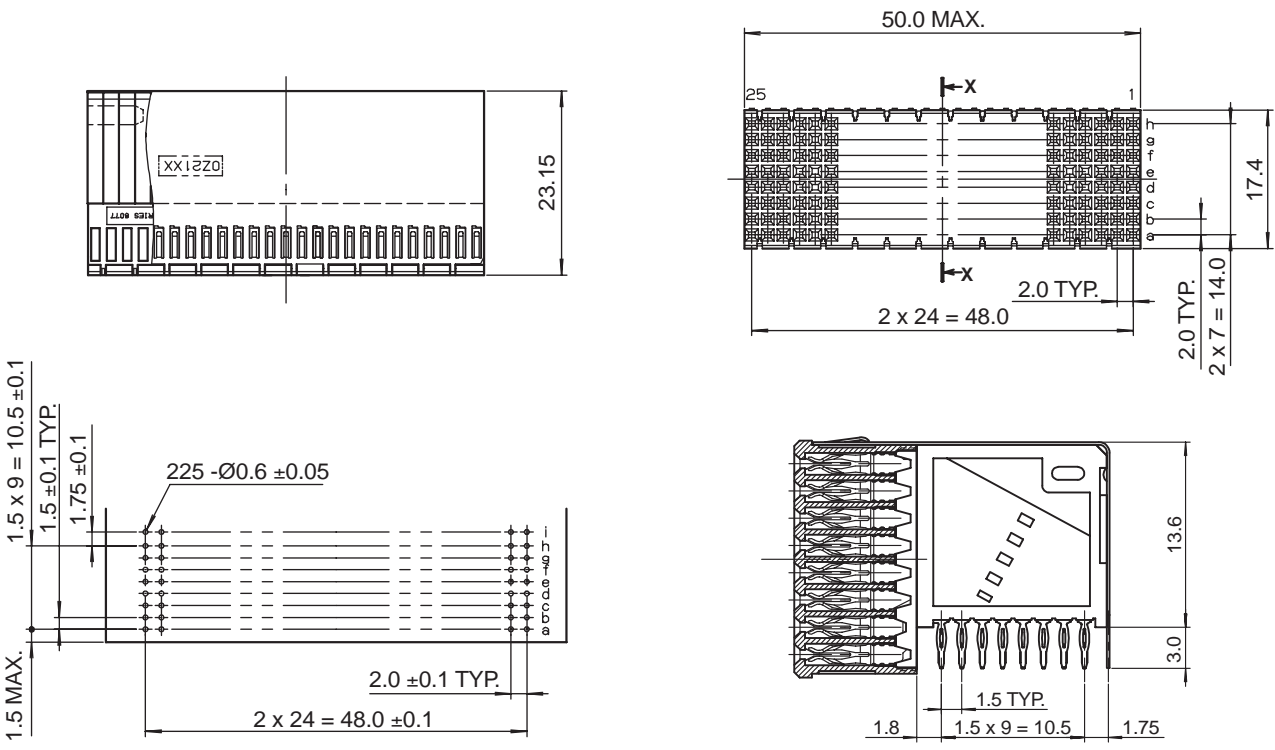

RECOMMENDED P.C. BOARD LAYOUT (COMPONENT SIDE)

Type F Right Angle Female for Daughter Cards

Series 8077

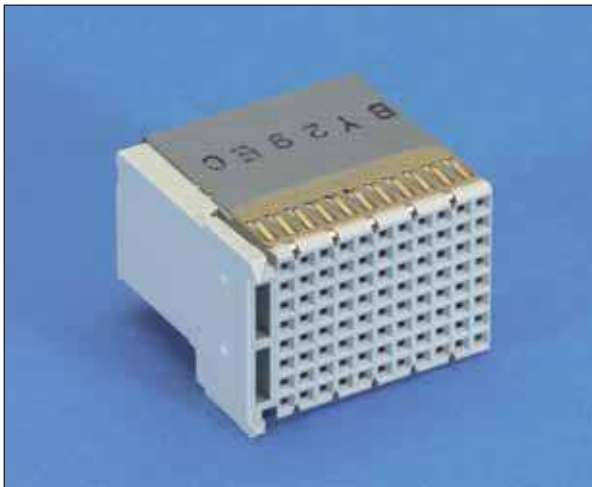

- 88 contacts in a 8 x 11 position configuration
- Designed for gas tight press-fit installation
- Available with or without upper ground return shield
- This connector can be used by itself or in conjunction with a Type D connector
- Should be used in end positions only



27 8077 088 001 863+ = Type F Right Angle Female without top shield
27 8077 088 011 863+ = Type F Right Angle Female with top shield

Plating Code	Contact Area	Press-fit Area	Under Coat
863	0.76µm min. Au	1.5-3.0µm Sn	1.2-3.0µm Ni

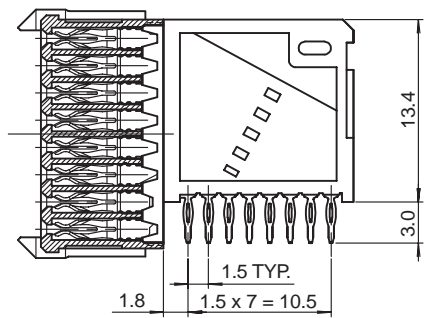
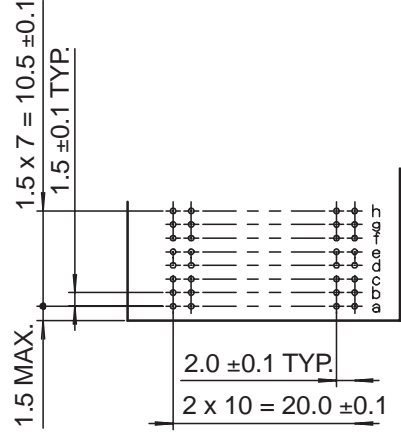
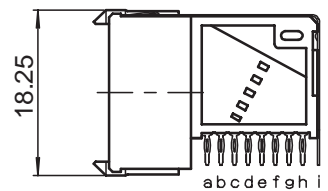
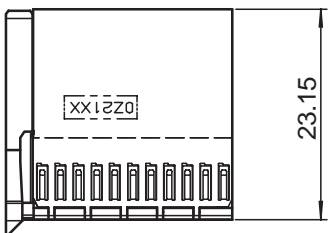
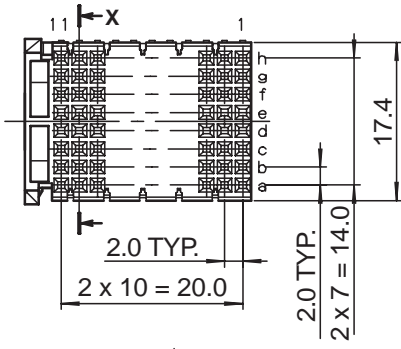

RECOMMENDED P.C. BOARD LAYOUT
(COMPONENT SIDE)

Type AB Right Angle Female for Daughter Cards

Series 8071

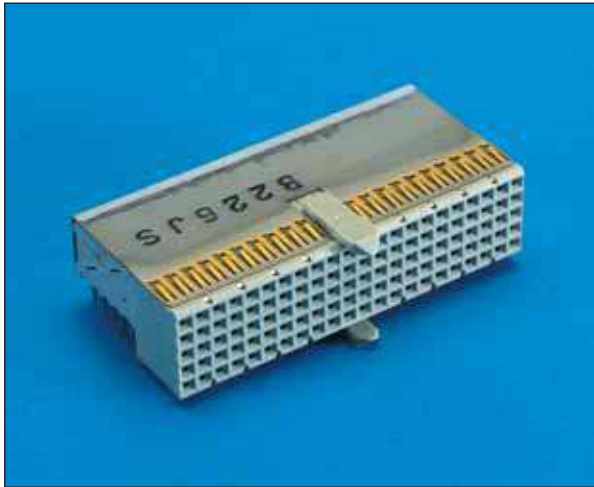

- 110 contacts in a 5 x 22 configuration
- Available with or without upper shield
- Designed for gas tight press-fit installation
- Available with or without upper ground return shield
- Prealignment guides
- This connector can be used by itself or in conjunction with a Type A, B, C female connector



27 8071 110 003 XXX+ = Type B 22 Vertical Female without upper shield

27 8071 110 013 XXX+ = Type B 22 Vertical Female with upper shield

XXX =

Plating Code	Contact Area	Press-fit Area	Under Coat
833	0.1µm min. Au.65µm Pd/Ni	1.5-3.0µm Sn	Nickel 1.2-3.0µm Ni
863	0.76µm min. Au	1.5-3.0µm Sn	Nickel 1.2-3.0µm Ni

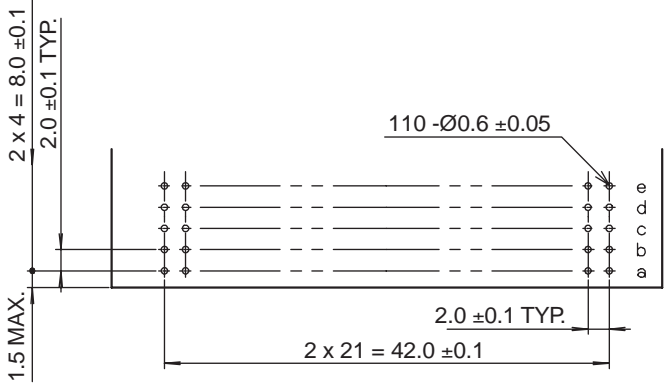
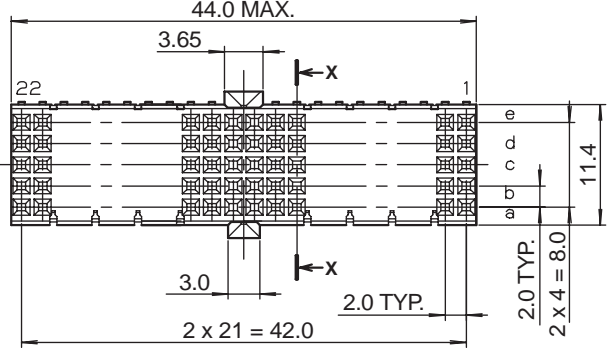
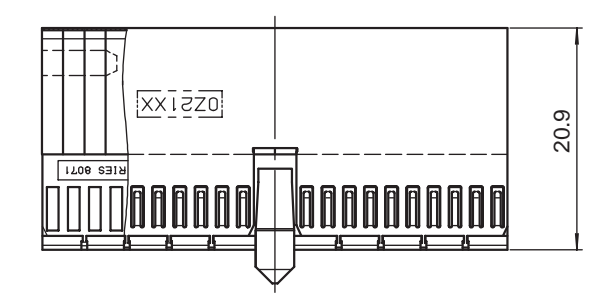

RECOMMENDED P.C. BOARD LAYOUT (COMPONENT SIDE)

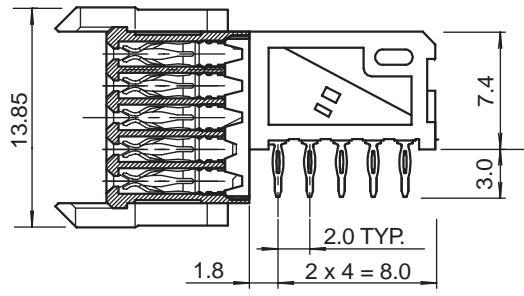

Type AB Right Angle Female for Daughter Cards

Series 8071

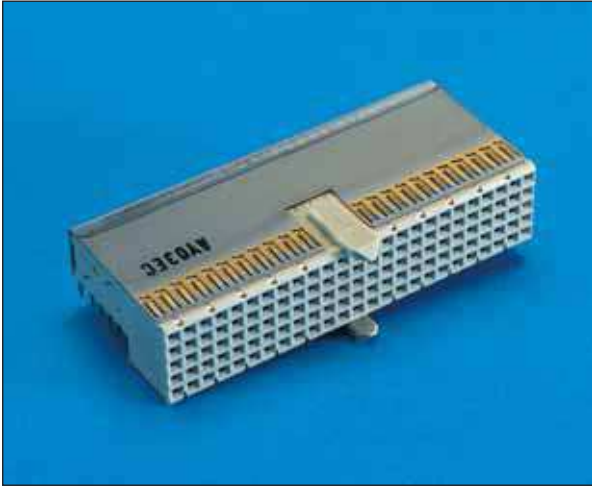

- 125 contacts in a 5 x 25 configuration
- Available with or without upper shield
- Designed for gas tight press-fit installation
- Available with or without upper ground return shield
- Prealignment guides
- This connector can be used by itself or in conjunction with Type A, B & C female connectors



27 8071 125 003 863+ = Type AB Right Angle Female without upper shield

27 8071 125 013 863+ = Type AB Right Angle Female with upper shield

Plating Code	Contact Area	Press-fit Area	Under Coat
863	0.76µm min. Au	1.5-3.0µm Sn	1.2-3.0µm Ni

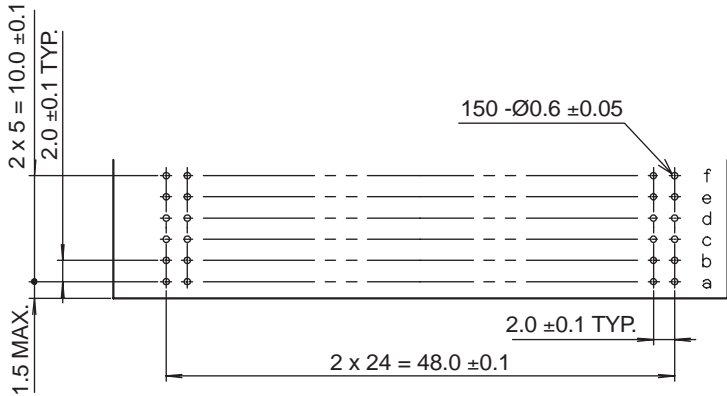
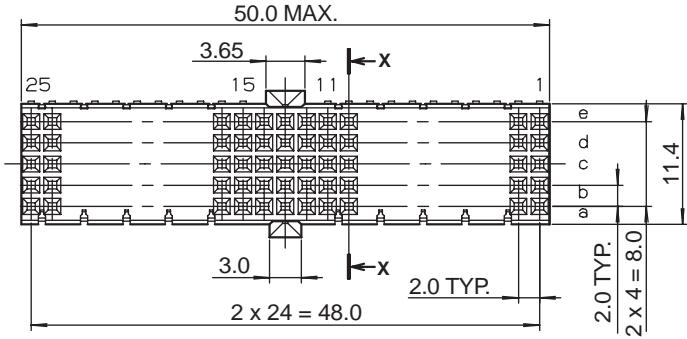
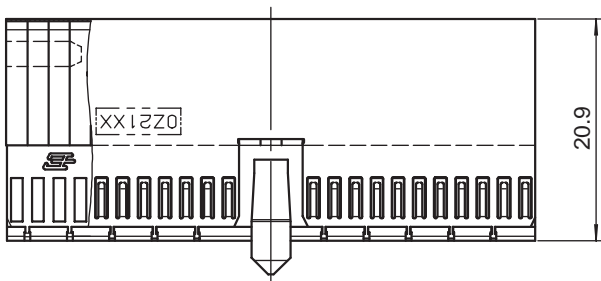

RECOMMENDED P.C. BOARD LAYOUT (COMPONENT SIDE)

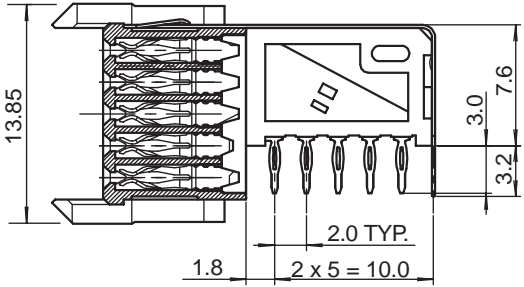

Type L Right Angle Female for Daughter Cards



Series 8074



- 6 power or coax contact cavities configuration
- Center cavity with prealignment guides and keying option
- See pages 52 and 53 for keying options
- Available with or without board locating pegs
- This connector can be used by itself or in conjunction with Style B, C, or M connectors
- Contacts are ordered separately
- See pages 54 and 55 for available contacts



62 8074 006 011 007+ = Type L Right Angle Female with mounting peg

62 8074 006 111 007+ = Type L Right Angle Female without mounting peg

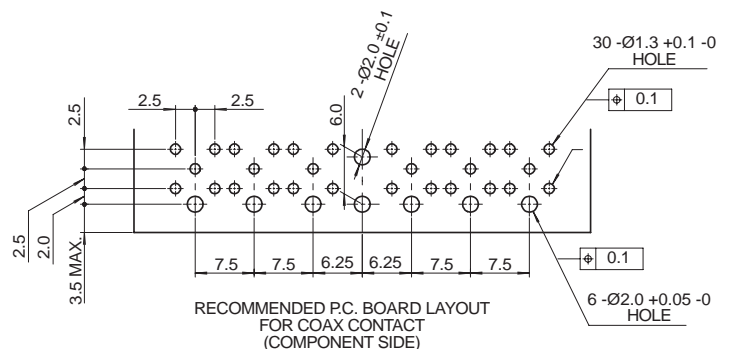
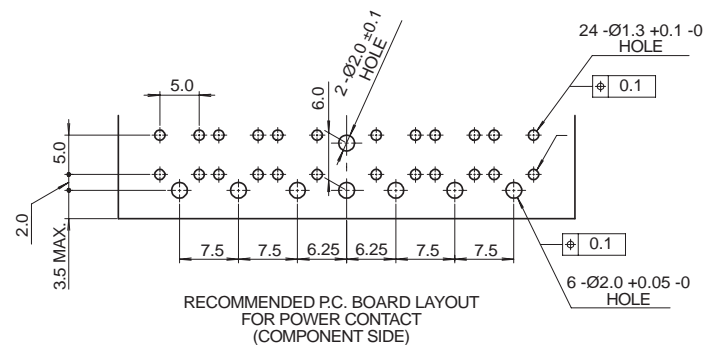
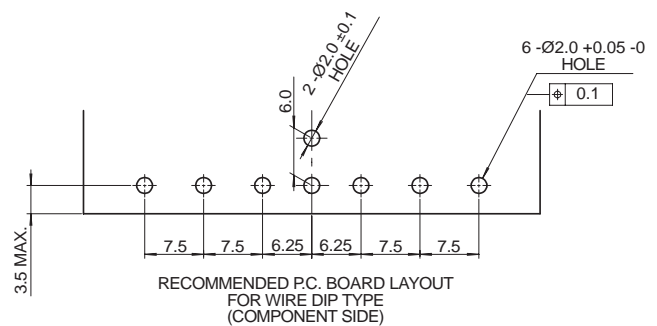
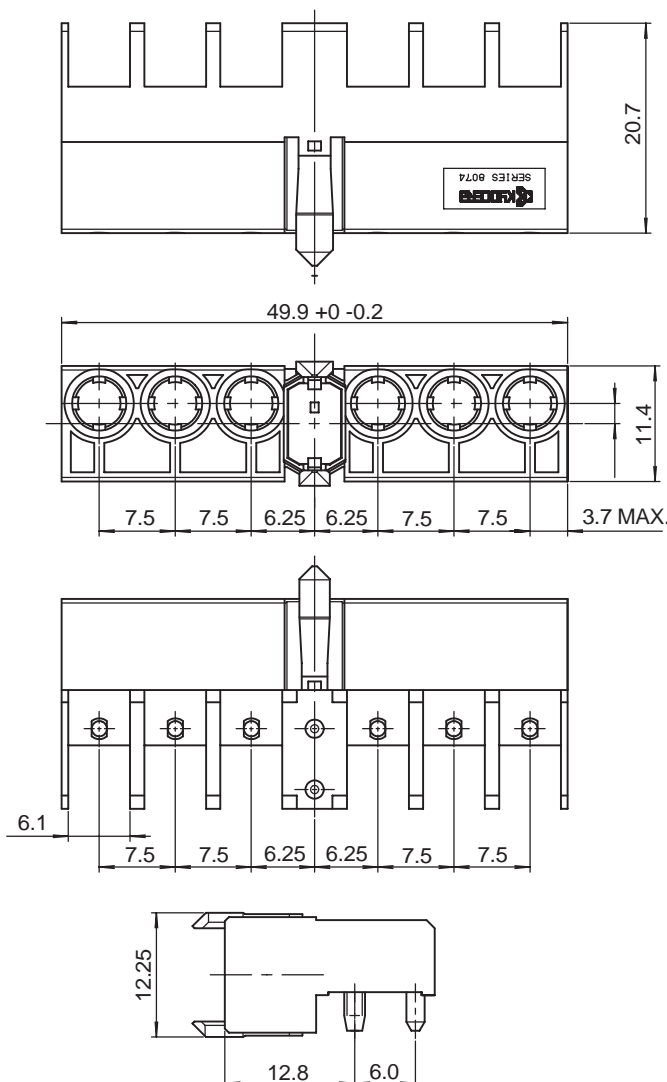

Type M Right Angle Female for Daughter Cards

Series 8075

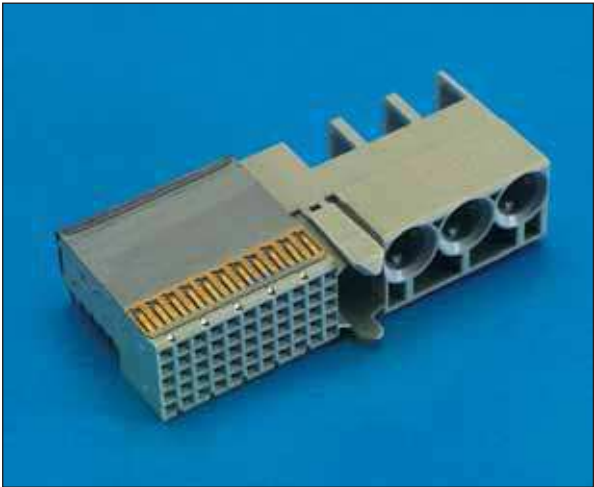

- 55 signal contacts in a 5 x 11 position configuration
- 3 positions for power or coax contacts
- Center cavity with prealignment guides and keying option
- See pages 52 and 53 for keying options
- Designed for gas tight press-fit installation
- This connector can be used by itself or in conjunction with Style A, B, C, or L connectors
- See pages 54 and 55 for available contacts



27 8075 355 011 XXX+ = Type M Right Angle Female with shield, with peg

27 8075 355 012 XXX+ = Type M Right Angle Female with shield, without peg

XXX =

Plating Code	Contact Area	Press-fit Area	Under Coat
833	0.1µm min. Au.65µm Pd/Ni	1.5-3.0µm Sn	1.2-3.0µm Ni
863	0.76µm min. Au	1.5-3.0µm Sn	1.2-3.0µm Ni

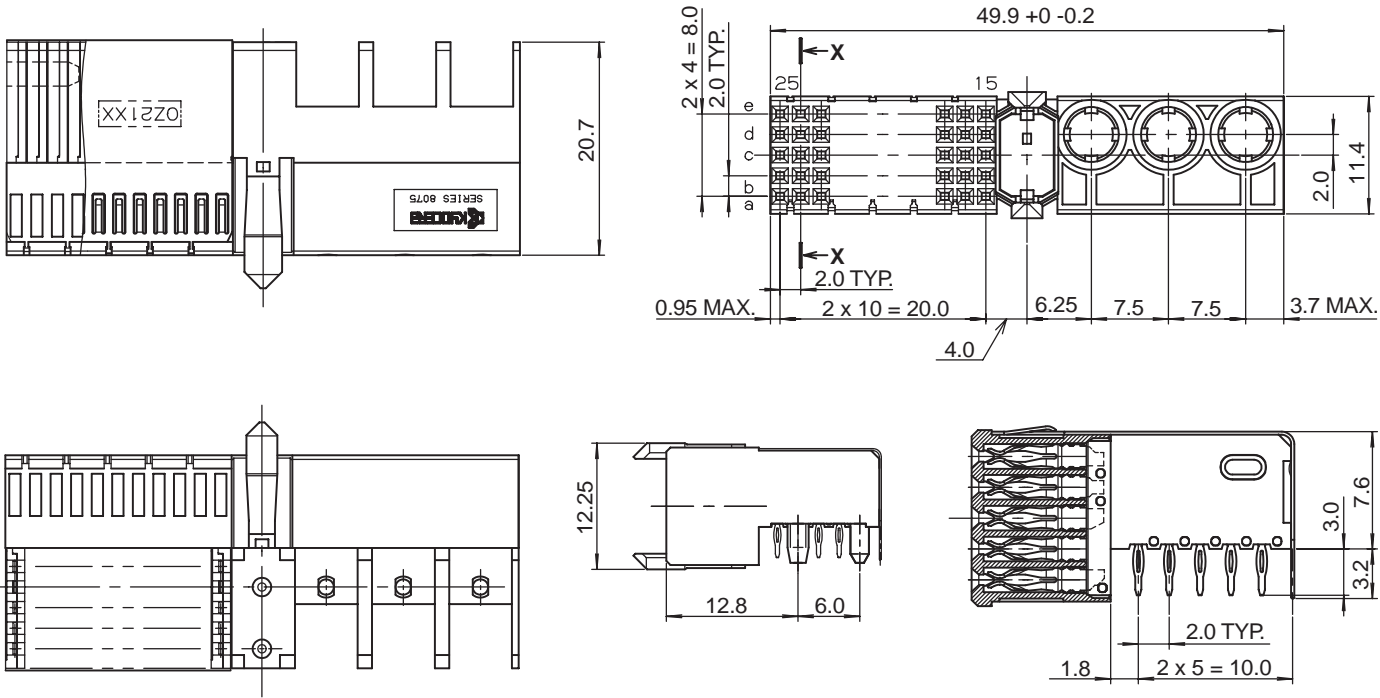

Type M Right Angle Female for Daughter Cards



Series 8075

BOARD LAYOUT

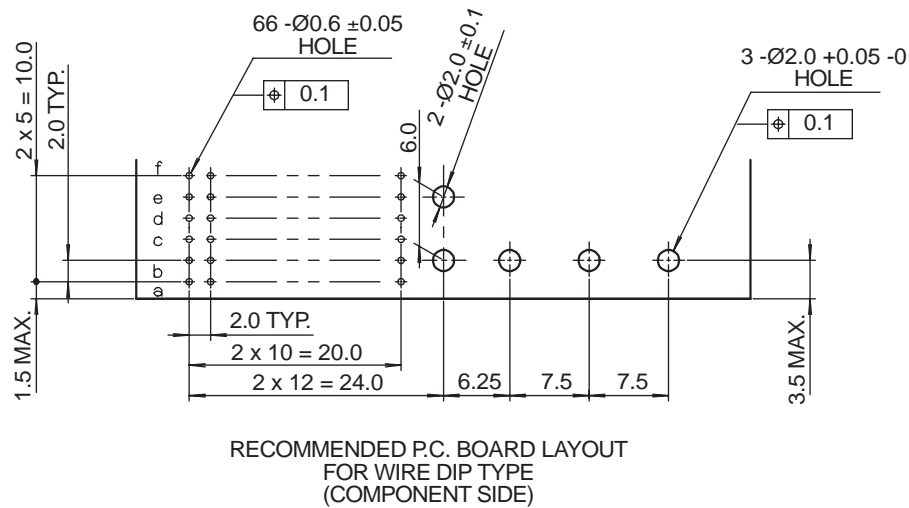
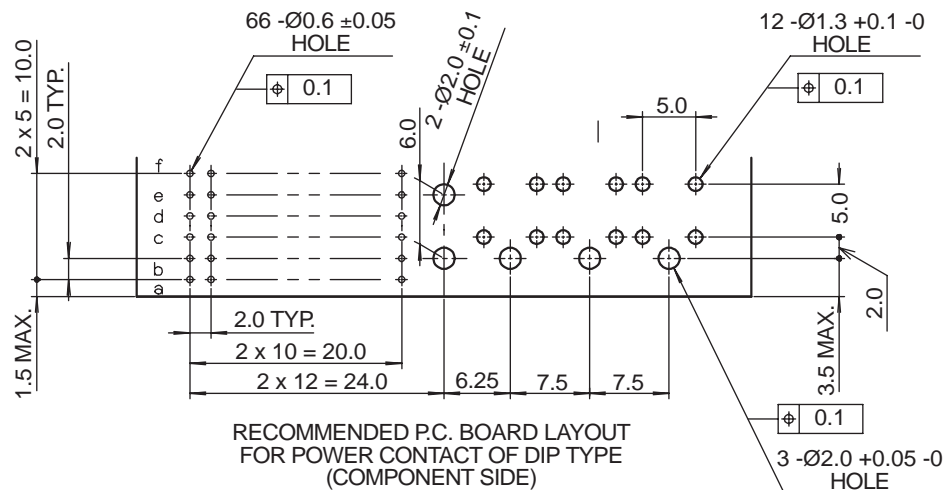
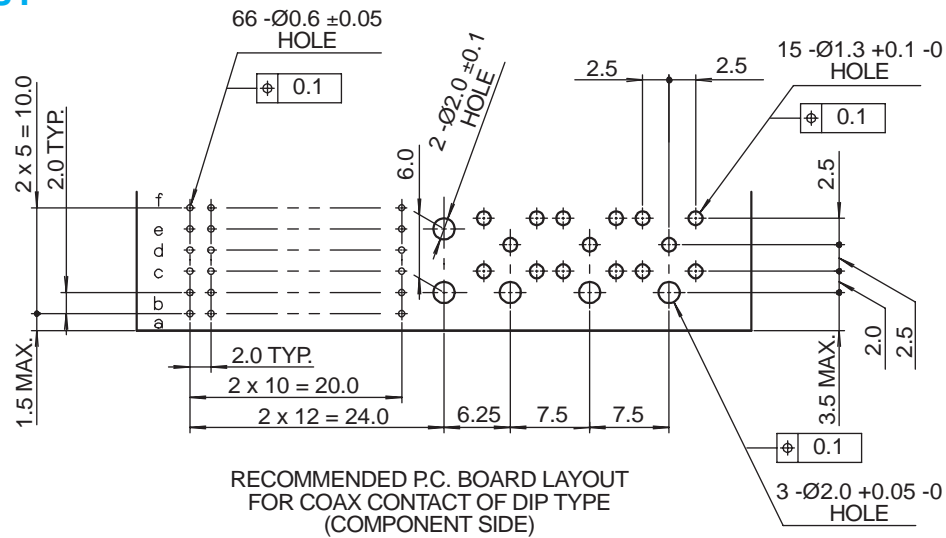

Type A Vertical Female for Backplanes

Series 8072

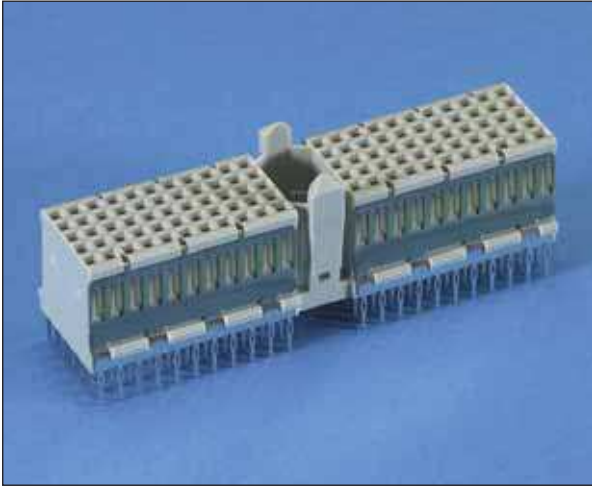

- 110 contacts in a 5 x 25 configuration
- Center cavity with prealignment guides and keying option (uses 3 positions)
- See pages 52 and 53 for keying options
- Available with or without side shields
- Designed for gas tight press-fit installation
- Can be used by itself or in conjunction with Type B & C vertical females



27 8072 110 001 863+ = Type A Vertical Female without side shields

27 8072 110 011 863+ = Type A Vertical Female with side shields

Plating Code	Contact Area	Press-fit Area	Under Coat
863	0.76µm min. Au	1.5-3.0µm Sn	1.2-3.0µm Ni

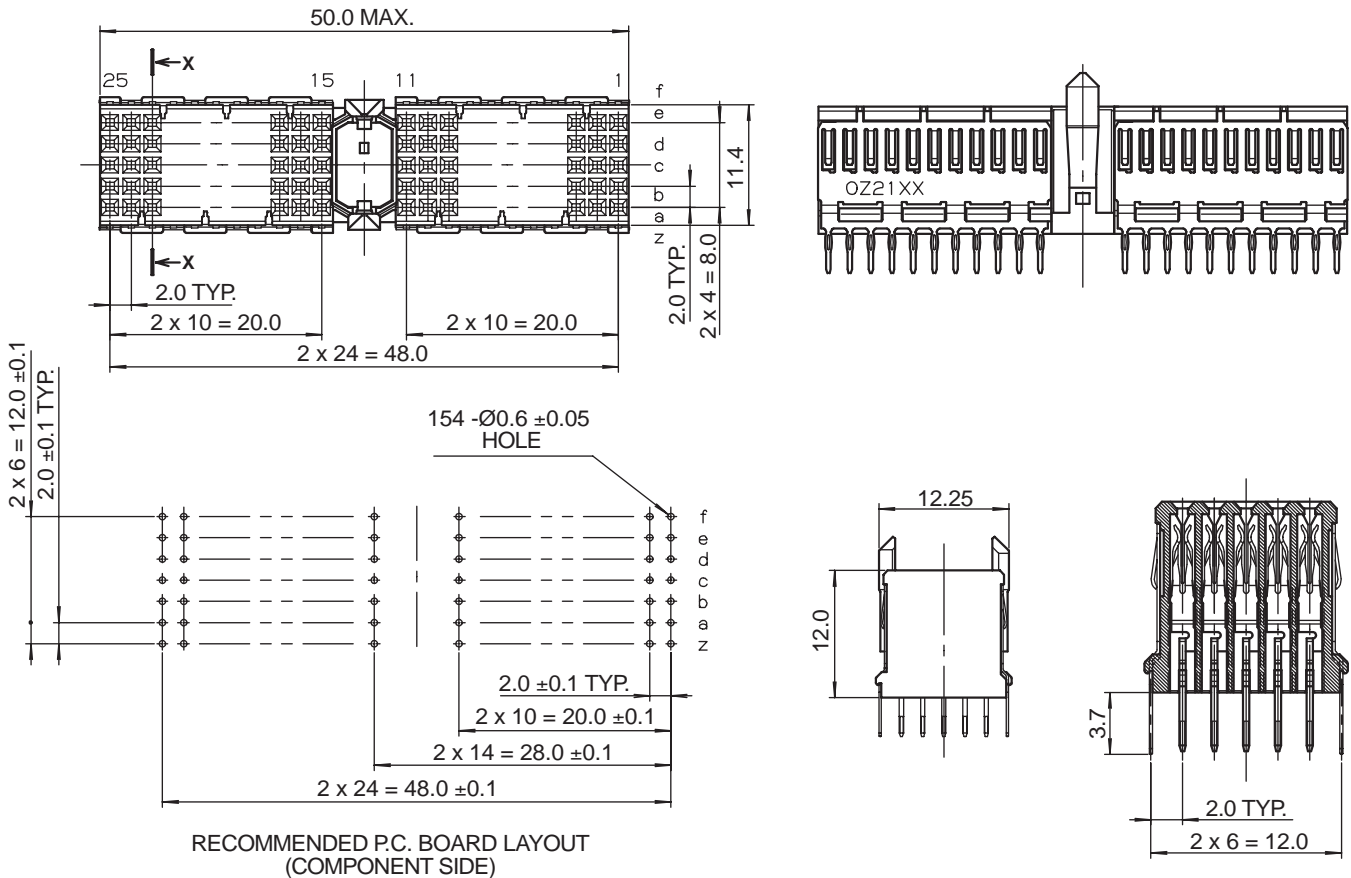

Type B Vertical Female for Backplanes



Series 8072

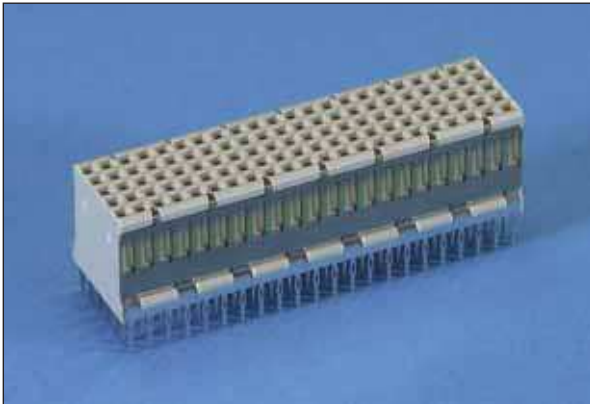

- 95, 110, 125 contacts in a 5 x 19, 5 x 22 or 5 x 25 configuration
- Available with or without side shields
- Designed for gas tight press-fit installation
- These connectors should be used in conjunction with a Type A Vertical Female connector



- 27 8072 095 001 XXX+** = Type B19 Vertical Female without side shields
- 27 8072 095 011 XXX+** = Type B19 Vertical Female with side shields
- 27 8072 110 000 XXX+** = Type B22 Vertical Female without side shields
- 27 8072 110 010 XXX+** = Type B22 Vertical Female with side shields
- 27 8072 125 000 863+** = Type B25 Vertical Female without side shields
- 27 8072 125 010 863+** = Type B25 Vertical Female with side shields

XXX =

Plating Code	Contact Area	Press-fit Area	Under Coat
833	0.1µm min. Au.65µm Pd/Ni	1.5-3.0µm Sn	1.2-3.0µm Ni
863	0.76µm min. Au	1.5-3.0µm Sn	1.2-3.0µm Ni

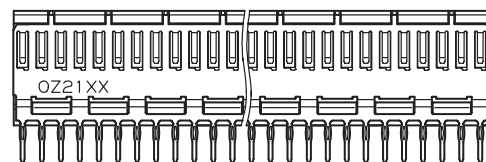
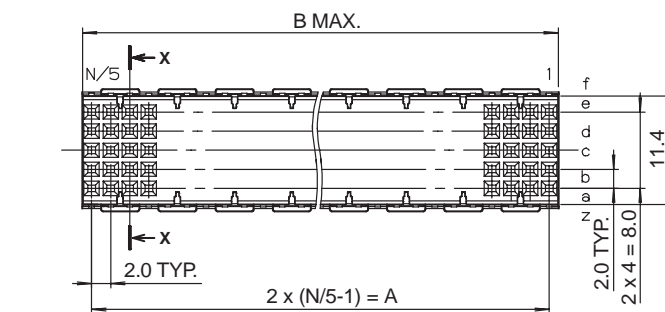

NO. OF POSITIONS	A	B
95	36.0	38.0
110	42.0	44.0
125	48.0	50.0

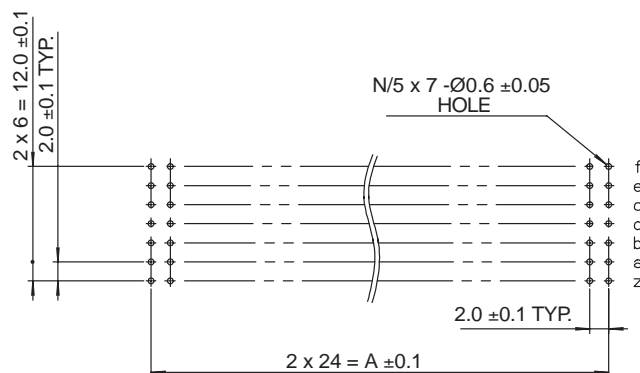

RECOMMENDED PC. BOARD LAYOUT (COMPONENT SIDE)

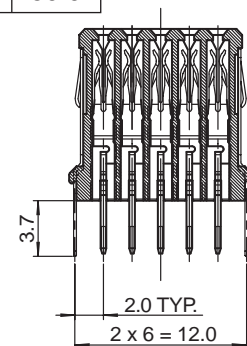
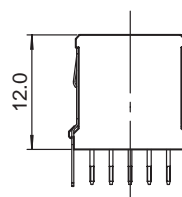

Vertical Male

Series 7200 – Style A 25, 154 Contacts

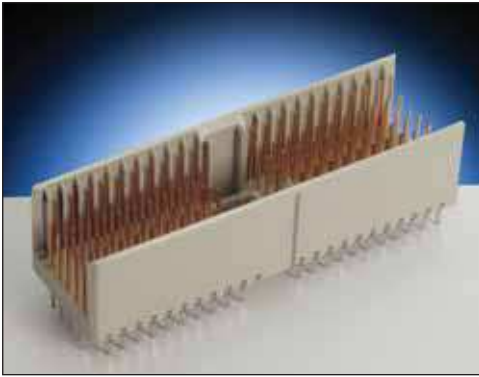

- Up to 110 signal contacts and 44 ground shield contacts in 5 or 5+2 rows of 25 positions
- Center cavity with keying option (uses 3 positions)
- See pages 52 and 53 for keying options
- Designed for gas tight press-fit installations
- This connector can be used by itself or in conjunction with Style B or C connectors
- Twelve different contact styles are available for customizing connector to exact specifications (complete form on page 57)
- Used in positions P1 and P4 of CompactPCI® specification
- Prealignment guides



DIMENSIONS: millimeters (inches)

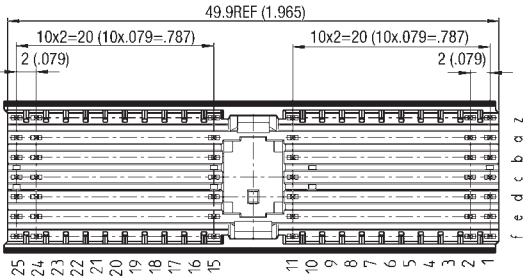
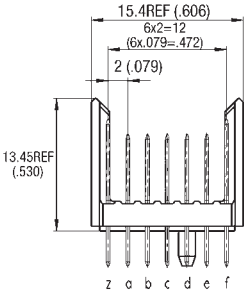
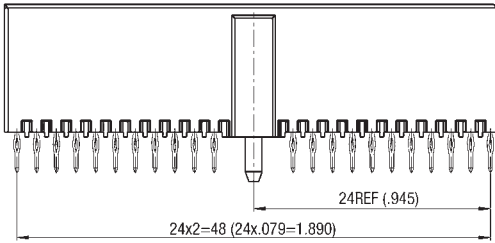

LAYOUT

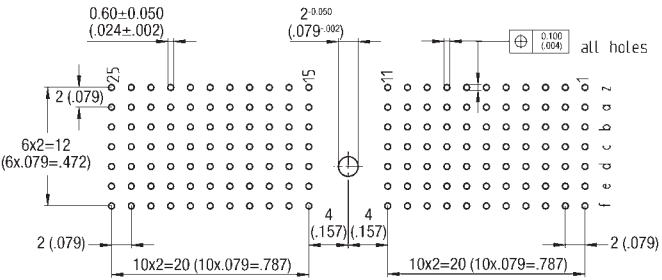

Vertical Male

Style A 25 – 154 Contacts



Pin Loading	Contacts	Performance Class	Part Number																																																																																																																																																																																																															
<table border="1"> <tr><td>25</td><td>24</td><td>23</td><td>22</td><td>21</td><td>20</td><td>19</td><td>18</td><td>17</td><td>16</td><td>15</td><td>14</td><td>13</td><td>12</td><td>11</td><td>10</td><td>9</td><td>8</td><td>7</td><td>6</td><td>5</td><td>4</td><td>3</td><td>2</td><td>1</td></tr> <tr><td>C</td><td>C</td><td>C</td><td>C</td><td>C</td><td>C</td><td>C</td><td>C</td><td>C</td><td>C</td><td>C</td><td>C</td><td>C</td><td>C</td><td>C</td><td>C</td><td>C</td><td>C</td><td>C</td><td>C</td><td>C</td><td>C</td><td>C</td><td>C</td><td>C</td><td>z</td></tr> <tr><td>A</td><td>A</td><td>A</td><td>A</td><td>A</td><td>A</td><td>A</td><td>A</td><td>A</td><td>A</td><td>A</td><td>A</td><td>A</td><td>A</td><td>A</td><td>A</td><td>A</td><td>A</td><td>A</td><td>A</td><td>A</td><td>A</td><td>A</td><td>A</td><td>A</td><td>a</td></tr> <tr><td>A</td><td>A</td><td>A</td><td>A</td><td>A</td><td>A</td><td>A</td><td>A</td><td>A</td><td>A</td><td>A</td><td>A</td><td>A</td><td>A</td><td>A</td><td>A</td><td>A</td><td>A</td><td>A</td><td>A</td><td>A</td><td>A</td><td>A</td><td>A</td><td>A</td><td>b</td></tr> <tr><td>A</td><td>A</td><td>A</td><td>A</td><td>A</td><td>A</td><td>A</td><td>A</td><td>A</td><td>A</td><td>A</td><td>A</td><td>A</td><td>A</td><td>A</td><td>A</td><td>A</td><td>A</td><td>A</td><td>A</td><td>A</td><td>A</td><td>A</td><td>A</td><td>A</td><td>c</td></tr> <tr><td>A</td><td>A</td><td>A</td><td>A</td><td>A</td><td>A</td><td>A</td><td>A</td><td>A</td><td>A</td><td>A</td><td>A</td><td>A</td><td>A</td><td>A</td><td>A</td><td>A</td><td>A</td><td>A</td><td>A</td><td>A</td><td>A</td><td>A</td><td>A</td><td>A</td><td>d</td></tr> <tr><td>A</td><td>A</td><td>A</td><td>A</td><td>A</td><td>A</td><td>A</td><td>A</td><td>A</td><td>A</td><td>A</td><td>A</td><td>A</td><td>A</td><td>A</td><td>A</td><td>A</td><td>A</td><td>A</td><td>A</td><td>A</td><td>A</td><td>A</td><td>A</td><td>A</td><td>e</td></tr> <tr><td>C</td><td>C</td><td>C</td><td>C</td><td>C</td><td>C</td><td>C</td><td>C</td><td>C</td><td>C</td><td>C</td><td>C</td><td>C</td><td>C</td><td>C</td><td>C</td><td>C</td><td>C</td><td>C</td><td>C</td><td>C</td><td>C</td><td>C</td><td>C</td><td>C</td><td>f</td></tr> </table>	25	24	23	22	21	20	19	18	17	16	15	14	13	12	11	10	9	8	7	6	5	4	3	2	1	C	C	C	C	C	C	C	C	C	C	C	C	C	C	C	C	C	C	C	C	C	C	C	C	C	z	A	A	A	A	A	A	A	A	A	A	A	A	A	A	A	A	A	A	A	A	A	A	A	A	A	a	A	A	A	A	A	A	A	A	A	A	A	A	A	A	A	A	A	A	A	A	A	A	A	A	A	b	A	A	A	A	A	A	A	A	A	A	A	A	A	A	A	A	A	A	A	A	A	A	A	A	A	c	A	A	A	A	A	A	A	A	A	A	A	A	A	A	A	A	A	A	A	A	A	A	A	A	A	d	A	A	A	A	A	A	A	A	A	A	A	A	A	A	A	A	A	A	A	A	A	A	A	A	A	e	C	C	C	C	C	C	C	C	C	C	C	C	C	C	C	C	C	C	C	C	C	C	C	C	C	f	154	2	17 7200 154 000 002
25	24	23	22	21	20	19	18	17	16	15	14	13	12	11	10	9	8	7	6	5	4	3	2	1																																																																																																																																																																																										
C	C	C	C	C	C	C	C	C	C	C	C	C	C	C	C	C	C	C	C	C	C	C	C	C	z																																																																																																																																																																																									
A	A	A	A	A	A	A	A	A	A	A	A	A	A	A	A	A	A	A	A	A	A	A	A	A	a																																																																																																																																																																																									
A	A	A	A	A	A	A	A	A	A	A	A	A	A	A	A	A	A	A	A	A	A	A	A	A	b																																																																																																																																																																																									
A	A	A	A	A	A	A	A	A	A	A	A	A	A	A	A	A	A	A	A	A	A	A	A	A	c																																																																																																																																																																																									
A	A	A	A	A	A	A	A	A	A	A	A	A	A	A	A	A	A	A	A	A	A	A	A	A	d																																																																																																																																																																																									
A	A	A	A	A	A	A	A	A	A	A	A	A	A	A	A	A	A	A	A	A	A	A	A	A	e																																																																																																																																																																																									
C	C	C	C	C	C	C	C	C	C	C	C	C	C	C	C	C	C	C	C	C	C	C	C	C	f																																																																																																																																																																																									
<table border="1"> <tr><td>25</td><td>24</td><td>23</td><td>22</td><td>21</td><td>20</td><td>19</td><td>18</td><td>17</td><td>16</td><td>15</td><td>14</td><td>13</td><td>12</td><td>11</td><td>10</td><td>9</td><td>8</td><td>7</td><td>6</td><td>5</td><td>4</td><td>3</td><td>2</td><td>1</td></tr> <tr><td>C</td><td>C</td><td>C</td><td>C</td><td>C</td><td>C</td><td>C</td><td>C</td><td>C</td><td>C</td><td>C</td><td>C</td><td>C</td><td>C</td><td>C</td><td>C</td><td>C</td><td>C</td><td>C</td><td>C</td><td>C</td><td>C</td><td>C</td><td>C</td><td>C</td><td>z</td></tr> <tr><td>B</td><td>B</td><td>B</td><td>B</td><td>B</td><td>B</td><td>B</td><td>B</td><td>B</td><td>B</td><td>B</td><td>B</td><td>B</td><td>B</td><td>B</td><td>B</td><td>B</td><td>B</td><td>B</td><td>B</td><td>B</td><td>B</td><td>B</td><td>B</td><td>B</td><td>a</td></tr> <tr><td>B</td><td>B</td><td>B</td><td>B</td><td>B</td><td>B</td><td>B</td><td>B</td><td>B</td><td>B</td><td>B</td><td>B</td><td>B</td><td>B</td><td>B</td><td>B</td><td>B</td><td>B</td><td>B</td><td>B</td><td>B</td><td>B</td><td>B</td><td>B</td><td>B</td><td>b</td></tr> <tr><td>B</td><td>B</td><td>B</td><td>B</td><td>B</td><td>B</td><td>B</td><td>B</td><td>B</td><td>B</td><td>B</td><td>B</td><td>B</td><td>B</td><td>B</td><td>B</td><td>B</td><td>B</td><td>B</td><td>B</td><td>B</td><td>B</td><td>B</td><td>B</td><td>B</td><td>c</td></tr> <tr><td>B</td><td>B</td><td>B</td><td>B</td><td>B</td><td>B</td><td>B</td><td>B</td><td>B</td><td>B</td><td>B</td><td>B</td><td>B</td><td>B</td><td>B</td><td>B</td><td>B</td><td>B</td><td>B</td><td>B</td><td>B</td><td>B</td><td>B</td><td>B</td><td>B</td><td>d</td></tr> <tr><td>B</td><td>B</td><td>B</td><td>B</td><td>B</td><td>B</td><td>B</td><td>B</td><td>B</td><td>B</td><td>B</td><td>B</td><td>B</td><td>B</td><td>B</td><td>B</td><td>B</td><td>B</td><td>B</td><td>B</td><td>B</td><td>B</td><td>B</td><td>B</td><td>B</td><td>e</td></tr> <tr><td>C</td><td>C</td><td>C</td><td>C</td><td>C</td><td>C</td><td>C</td><td>C</td><td>C</td><td>C</td><td>C</td><td>C</td><td>C</td><td>C</td><td>C</td><td>C</td><td>C</td><td>C</td><td>C</td><td>C</td><td>C</td><td>C</td><td>C</td><td>C</td><td>C</td><td>f</td></tr> </table>	25	24	23	22	21	20	19	18	17	16	15	14	13	12	11	10	9	8	7	6	5	4	3	2	1	C	C	C	C	C	C	C	C	C	C	C	C	C	C	C	C	C	C	C	C	C	C	C	C	C	z	B	B	B	B	B	B	B	B	B	B	B	B	B	B	B	B	B	B	B	B	B	B	B	B	B	a	B	B	B	B	B	B	B	B	B	B	B	B	B	B	B	B	B	B	B	B	B	B	B	B	B	b	B	B	B	B	B	B	B	B	B	B	B	B	B	B	B	B	B	B	B	B	B	B	B	B	B	c	B	B	B	B	B	B	B	B	B	B	B	B	B	B	B	B	B	B	B	B	B	B	B	B	B	d	B	B	B	B	B	B	B	B	B	B	B	B	B	B	B	B	B	B	B	B	B	B	B	B	B	e	C	C	C	C	C	C	C	C	C	C	C	C	C	C	C	C	C	C	C	C	C	C	C	C	C	f	154	2	17 7200 154 001 002
25	24	23	22	21	20	19	18	17	16	15	14	13	12	11	10	9	8	7	6	5	4	3	2	1																																																																																																																																																																																										
C	C	C	C	C	C	C	C	C	C	C	C	C	C	C	C	C	C	C	C	C	C	C	C	C	z																																																																																																																																																																																									
B	B	B	B	B	B	B	B	B	B	B	B	B	B	B	B	B	B	B	B	B	B	B	B	B	a																																																																																																																																																																																									
B	B	B	B	B	B	B	B	B	B	B	B	B	B	B	B	B	B	B	B	B	B	B	B	B	b																																																																																																																																																																																									
B	B	B	B	B	B	B	B	B	B	B	B	B	B	B	B	B	B	B	B	B	B	B	B	B	c																																																																																																																																																																																									
B	B	B	B	B	B	B	B	B	B	B	B	B	B	B	B	B	B	B	B	B	B	B	B	B	d																																																																																																																																																																																									
B	B	B	B	B	B	B	B	B	B	B	B	B	B	B	B	B	B	B	B	B	B	B	B	B	e																																																																																																																																																																																									
C	C	C	C	C	C	C	C	C	C	C	C	C	C	C	C	C	C	C	C	C	C	C	C	C	f																																																																																																																																																																																									
<p align="center">CompactPCI®</p> <table border="1"> <tr><td>25</td><td>24</td><td>23</td><td>22</td><td>21</td><td>20</td><td>19</td><td>18</td><td>17</td><td>16</td><td>15</td><td>14</td><td>13</td><td>12</td><td>11</td><td>10</td><td>9</td><td>8</td><td>7</td><td>6</td><td>5</td><td>4</td><td>3</td><td>2</td><td>1</td></tr> <tr><td>T</td><td>T</td><td>T</td><td>T</td><td>T</td><td>T</td><td>T</td><td>T</td><td>T</td><td>T</td><td>T</td><td>T</td><td>T</td><td>T</td><td>T</td><td>T</td><td>T</td><td>T</td><td>T</td><td>T</td><td>T</td><td>T</td><td>T</td><td>T</td><td>T</td><td>z</td></tr> <tr><td>P</td><td>P</td><td>P</td><td>P</td><td>P</td><td>P</td><td>P</td><td>P</td><td>P</td><td>P</td><td>P</td><td>P</td><td>P</td><td>P</td><td>P</td><td>P</td><td>P</td><td>P</td><td>P</td><td>P</td><td>P</td><td>P</td><td>P</td><td>P</td><td>P</td><td>a</td></tr> <tr><td>P</td><td>P</td><td>P</td><td>P</td><td>P</td><td>P</td><td>P</td><td>P</td><td>P</td><td>P</td><td>P</td><td>P</td><td>P</td><td>P</td><td>P</td><td>P</td><td>P</td><td>P</td><td>P</td><td>P</td><td>P</td><td>P</td><td>P</td><td>P</td><td>P</td><td>b</td></tr> <tr><td>P</td><td>P</td><td>P</td><td>P</td><td>P</td><td>P</td><td>P</td><td>P</td><td>P</td><td>P</td><td>P</td><td>P</td><td>P</td><td>P</td><td>P</td><td>P</td><td>P</td><td>P</td><td>P</td><td>P</td><td>P</td><td>P</td><td>P</td><td>P</td><td>P</td><td>c</td></tr> <tr><td>P</td><td>P</td><td>P</td><td>P</td><td>P</td><td>P</td><td>P</td><td>P</td><td>P</td><td>P</td><td>P</td><td>P</td><td>P</td><td>P</td><td>P</td><td>P</td><td>P</td><td>P</td><td>P</td><td>P</td><td>P</td><td>P</td><td>P</td><td>P</td><td>P</td><td>d</td></tr> <tr><td>P</td><td>P</td><td>P</td><td>P</td><td>P</td><td>P</td><td>P</td><td>P</td><td>P</td><td>P</td><td>P</td><td>P</td><td>P</td><td>P</td><td>P</td><td>P</td><td>P</td><td>P</td><td>P</td><td>P</td><td>P</td><td>P</td><td>P</td><td>P</td><td>P</td><td>e</td></tr> <tr><td>T</td><td>T</td><td>T</td><td>T</td><td>T</td><td>T</td><td>T</td><td>T</td><td>T</td><td>T</td><td>T</td><td>T</td><td>T</td><td>T</td><td>T</td><td>T</td><td>T</td><td>T</td><td>T</td><td>T</td><td>T</td><td>T</td><td>T</td><td>T</td><td>T</td><td>f</td></tr> </table>	25	24	23	22	21	20	19	18	17	16	15	14	13	12	11	10	9	8	7	6	5	4	3	2	1	T	T	T	T	T	T	T	T	T	T	T	T	T	T	T	T	T	T	T	T	T	T	T	T	T	z	P	P	P	P	P	P	P	P	P	P	P	P	P	P	P	P	P	P	P	P	P	P	P	P	P	a	P	P	P	P	P	P	P	P	P	P	P	P	P	P	P	P	P	P	P	P	P	P	P	P	P	b	P	P	P	P	P	P	P	P	P	P	P	P	P	P	P	P	P	P	P	P	P	P	P	P	P	c	P	P	P	P	P	P	P	P	P	P	P	P	P	P	P	P	P	P	P	P	P	P	P	P	P	d	P	P	P	P	P	P	P	P	P	P	P	P	P	P	P	P	P	P	P	P	P	P	P	P	P	e	T	T	T	T	T	T	T	T	T	T	T	T	T	T	T	T	T	T	T	T	T	T	T	T	T	f	154	2	17 7200 154 002 005
25	24	23	22	21	20	19	18	17	16	15	14	13	12	11	10	9	8	7	6	5	4	3	2	1																																																																																																																																																																																										
T	T	T	T	T	T	T	T	T	T	T	T	T	T	T	T	T	T	T	T	T	T	T	T	T	z																																																																																																																																																																																									
P	P	P	P	P	P	P	P	P	P	P	P	P	P	P	P	P	P	P	P	P	P	P	P	P	a																																																																																																																																																																																									
P	P	P	P	P	P	P	P	P	P	P	P	P	P	P	P	P	P	P	P	P	P	P	P	P	b																																																																																																																																																																																									
P	P	P	P	P	P	P	P	P	P	P	P	P	P	P	P	P	P	P	P	P	P	P	P	P	c																																																																																																																																																																																									
P	P	P	P	P	P	P	P	P	P	P	P	P	P	P	P	P	P	P	P	P	P	P	P	P	d																																																																																																																																																																																									
P	P	P	P	P	P	P	P	P	P	P	P	P	P	P	P	P	P	P	P	P	P	P	P	P	e																																																																																																																																																																																									
T	T	T	T	T	T	T	T	T	T	T	T	T	T	T	T	T	T	T	T	T	T	T	T	T	f																																																																																																																																																																																									
<p align="center">CompactPCI®</p> <table border="1"> <tr><td>25</td><td>24</td><td>23</td><td>22</td><td>21</td><td>20</td><td>19</td><td>18</td><td>17</td><td>16</td><td>15</td><td>14</td><td>13</td><td>12</td><td>11</td><td>10</td><td>9</td><td>8</td><td>7</td><td>6</td><td>5</td><td>4</td><td>3</td><td>2</td><td>1</td></tr> <tr><td>T</td><td>T</td><td>T</td><td>T</td><td>T</td><td>T</td><td>T</td><td>T</td><td>T</td><td>T</td><td>T</td><td>T</td><td>T</td><td>T</td><td>T</td><td>T</td><td>T</td><td>T</td><td>T</td><td>T</td><td>T</td><td>T</td><td>T</td><td>T</td><td>T</td><td>z</td></tr> <tr><td>R</td><td>R</td><td>R</td><td>R</td><td>R</td><td>R</td><td>R</td><td>R</td><td>R</td><td>R</td><td>R</td><td>R</td><td>R</td><td>R</td><td>R</td><td>R</td><td>R</td><td>R</td><td>R</td><td>R</td><td>R</td><td>R</td><td>R</td><td>R</td><td>R</td><td>a</td></tr> <tr><td>R</td><td>R</td><td>R</td><td>R</td><td>R</td><td>R</td><td>R</td><td>R</td><td>R</td><td>R</td><td>R</td><td>R</td><td>R</td><td>R</td><td>R</td><td>R</td><td>R</td><td>R</td><td>R</td><td>R</td><td>R</td><td>R</td><td>R</td><td>R</td><td>R</td><td>b</td></tr> <tr><td>R</td><td>R</td><td>R</td><td>R</td><td>R</td><td>R</td><td>R</td><td>R</td><td>R</td><td>R</td><td>R</td><td>R</td><td>R</td><td>R</td><td>R</td><td>R</td><td>R</td><td>R</td><td>R</td><td>R</td><td>R</td><td>R</td><td>R</td><td>R</td><td>R</td><td>c</td></tr> <tr><td>R</td><td>R</td><td>R</td><td>R</td><td>R</td><td>R</td><td>R</td><td>R</td><td>R</td><td>R</td><td>R</td><td>R</td><td>R</td><td>R</td><td>R</td><td>R</td><td>R</td><td>R</td><td>R</td><td>R</td><td>R</td><td>R</td><td>R</td><td>R</td><td>R</td><td>d</td></tr> <tr><td>R</td><td>R</td><td>R</td><td>R</td><td>R</td><td>R</td><td>R</td><td>R</td><td>R</td><td>R</td><td>R</td><td>R</td><td>R</td><td>R</td><td>R</td><td>R</td><td>R</td><td>R</td><td>R</td><td>R</td><td>R</td><td>R</td><td>R</td><td>R</td><td>R</td><td>e</td></tr> <tr><td>T</td><td>T</td><td>T</td><td>T</td><td>T</td><td>T</td><td>T</td><td>T</td><td>T</td><td>T</td><td>T</td><td>T</td><td>T</td><td>T</td><td>T</td><td>T</td><td>T</td><td>T</td><td>T</td><td>T</td><td>T</td><td>T</td><td>T</td><td>T</td><td>T</td><td>f</td></tr> </table>	25	24	23	22	21	20	19	18	17	16	15	14	13	12	11	10	9	8	7	6	5	4	3	2	1	T	T	T	T	T	T	T	T	T	T	T	T	T	T	T	T	T	T	T	T	T	T	T	T	T	z	R	R	R	R	R	R	R	R	R	R	R	R	R	R	R	R	R	R	R	R	R	R	R	R	R	a	R	R	R	R	R	R	R	R	R	R	R	R	R	R	R	R	R	R	R	R	R	R	R	R	R	b	R	R	R	R	R	R	R	R	R	R	R	R	R	R	R	R	R	R	R	R	R	R	R	R	R	c	R	R	R	R	R	R	R	R	R	R	R	R	R	R	R	R	R	R	R	R	R	R	R	R	R	d	R	R	R	R	R	R	R	R	R	R	R	R	R	R	R	R	R	R	R	R	R	R	R	R	R	e	T	T	T	T	T	T	T	T	T	T	T	T	T	T	T	T	T	T	T	T	T	T	T	T	T	f	154	2	17 7200 154 003 005
25	24	23	22	21	20	19	18	17	16	15	14	13	12	11	10	9	8	7	6	5	4	3	2	1																																																																																																																																																																																										
T	T	T	T	T	T	T	T	T	T	T	T	T	T	T	T	T	T	T	T	T	T	T	T	T	z																																																																																																																																																																																									
R	R	R	R	R	R	R	R	R	R	R	R	R	R	R	R	R	R	R	R	R	R	R	R	R	a																																																																																																																																																																																									
R	R	R	R	R	R	R	R	R	R	R	R	R	R	R	R	R	R	R	R	R	R	R	R	R	b																																																																																																																																																																																									
R	R	R	R	R	R	R	R	R	R	R	R	R	R	R	R	R	R	R	R	R	R	R	R	R	c																																																																																																																																																																																									
R	R	R	R	R	R	R	R	R	R	R	R	R	R	R	R	R	R	R	R	R	R	R	R	R	d																																																																																																																																																																																									
R	R	R	R	R	R	R	R	R	R	R	R	R	R	R	R	R	R	R	R	R	R	R	R	R	e																																																																																																																																																																																									
T	T	T	T	T	T	T	T	T	T	T	T	T	T	T	T	T	T	T	T	T	T	T	T	T	f																																																																																																																																																																																									
<table border="1"> <tr><td>25</td><td>24</td><td>23</td><td>22</td><td>21</td><td>20</td><td>19</td><td>18</td><td>17</td><td>16</td><td>15</td><td>14</td><td>13</td><td>12</td><td>11</td><td>10</td><td>9</td><td>8</td><td>7</td><td>6</td><td>5</td><td>4</td><td>3</td><td>2</td><td>1</td></tr> <tr><td>T</td><td>T</td><td>T</td><td>T</td><td>T</td><td>T</td><td>T</td><td>T</td><td>T</td><td>T</td><td>T</td><td>T</td><td>T</td><td>T</td><td>T</td><td>T</td><td>T</td><td>T</td><td>T</td><td>T</td><td>T</td><td>T</td><td>T</td><td>T</td><td>T</td><td>z</td></tr> <tr><td>K</td><td>K</td><td>K</td><td>K</td><td>K</td><td>K</td><td>K</td><td>K</td><td>K</td><td>K</td><td>K</td><td>K</td><td>K</td><td>K</td><td>K</td><td>K</td><td>K</td><td>K</td><td>K</td><td>K</td><td>K</td><td>K</td><td>K</td><td>K</td><td>K</td><td>a</td></tr> <tr><td>K</td><td>K</td><td>K</td><td>K</td><td>K</td><td>K</td><td>K</td><td>K</td><td>K</td><td>K</td><td>K</td><td>K</td><td>K</td><td>K</td><td>K</td><td>K</td><td>K</td><td>K</td><td>K</td><td>K</td><td>K</td><td>K</td><td>K</td><td>K</td><td>K</td><td>b</td></tr> <tr><td>K</td><td>K</td><td>K</td><td>K</td><td>K</td><td>K</td><td>K</td><td>K</td><td>K</td><td>K</td><td>K</td><td>K</td><td>K</td><td>K</td><td>K</td><td>K</td><td>K</td><td>K</td><td>K</td><td>K</td><td>K</td><td>K</td><td>K</td><td>K</td><td>K</td><td>c</td></tr> <tr><td>K</td><td>K</td><td>K</td><td>K</td><td>K</td><td>K</td><td>K</td><td>K</td><td>K</td><td>K</td><td>K</td><td>K</td><td>K</td><td>K</td><td>K</td><td>K</td><td>K</td><td>K</td><td>K</td><td>K</td><td>K</td><td>K</td><td>K</td><td>K</td><td>K</td><td>d</td></tr> <tr><td>K</td><td>K</td><td>K</td><td>K</td><td>K</td><td>K</td><td>K</td><td>K</td><td>K</td><td>K</td><td>K</td><td>K</td><td>K</td><td>K</td><td>K</td><td>K</td><td>K</td><td>K</td><td>K</td><td>K</td><td>K</td><td>K</td><td>K</td><td>K</td><td>K</td><td>e</td></tr> <tr><td>T</td><td>T</td><td>T</td><td>T</td><td>T</td><td>T</td><td>T</td><td>T</td><td>T</td><td>T</td><td>T</td><td>T</td><td>T</td><td>T</td><td>T</td><td>T</td><td>T</td><td>T</td><td>T</td><td>T</td><td>T</td><td>T</td><td>T</td><td>T</td><td>T</td><td>f</td></tr> </table>	25	24	23	22	21	20	19	18	17	16	15	14	13	12	11	10	9	8	7	6	5	4	3	2	1	T	T	T	T	T	T	T	T	T	T	T	T	T	T	T	T	T	T	T	T	T	T	T	T	T	z	K	K	K	K	K	K	K	K	K	K	K	K	K	K	K	K	K	K	K	K	K	K	K	K	K	a	K	K	K	K	K	K	K	K	K	K	K	K	K	K	K	K	K	K	K	K	K	K	K	K	K	b	K	K	K	K	K	K	K	K	K	K	K	K	K	K	K	K	K	K	K	K	K	K	K	K	K	c	K	K	K	K	K	K	K	K	K	K	K	K	K	K	K	K	K	K	K	K	K	K	K	K	K	d	K	K	K	K	K	K	K	K	K	K	K	K	K	K	K	K	K	K	K	K	K	K	K	K	K	e	T	T	T	T	T	T	T	T	T	T	T	T	T	T	T	T	T	T	T	T	T	T	T	T	T	f	154	2	17 7200 154 004 005
25	24	23	22	21	20	19	18	17	16	15	14	13	12	11	10	9	8	7	6	5	4	3	2	1																																																																																																																																																																																										
T	T	T	T	T	T	T	T	T	T	T	T	T	T	T	T	T	T	T	T	T	T	T	T	T	z																																																																																																																																																																																									
K	K	K	K	K	K	K	K	K	K	K	K	K	K	K	K	K	K	K	K	K	K	K	K	K	a																																																																																																																																																																																									
K	K	K	K	K	K	K	K	K	K	K	K	K	K	K	K	K	K	K	K	K	K	K	K	K	b																																																																																																																																																																																									
K	K	K	K	K	K	K	K	K	K	K	K	K	K	K	K	K	K	K	K	K	K	K	K	K	c																																																																																																																																																																																									
K	K	K	K	K	K	K	K	K	K	K	K	K	K	K	K	K	K	K	K	K	K	K	K	K	d																																																																																																																																																																																									
K	K	K	K	K	K	K	K	K	K	K	K	K	K	K	K	K	K	K	K	K	K	K	K	K	e																																																																																																																																																																																									
T	T	T	T	T	T	T	T	T	T	T	T	T	T	T	T	T	T	T	T	T	T	T	T	T	f																																																																																																																																																																																									
<p align="center">CompactPCI® P1 / P4</p> <table border="1"> <tr><td>25</td><td>24</td><td>23</td><td>22</td><td>21</td><td>20</td><td>19</td><td>18</td><td>17</td><td>16</td><td>15</td><td>14</td><td>13</td><td>12</td><td>11</td><td>10</td><td>9</td><td>8</td><td>7</td><td>6</td><td>5</td><td>4</td><td>3</td><td>2</td><td>1</td></tr> <tr><td>C</td><td>C</td><td>C</td><td>C</td><td>C</td><td>C</td><td>C</td><td>C</td><td>C</td><td>C</td><td>C</td><td>C</td><td>C</td><td>C</td><td>C</td><td>C</td><td>C</td><td>C</td><td>C</td><td>C</td><td>C</td><td>C</td><td>C</td><td>C</td><td>C</td><td>z</td></tr> <tr><td>B</td><td>B</td><td>B</td><td>B</td><td>B</td><td>B</td><td>B</td><td>B</td><td>B</td><td>B</td><td>B</td><td>B</td><td>B</td><td>B</td><td>B</td><td>B</td><td>B</td><td>B</td><td>B</td><td>B</td><td>B</td><td>B</td><td>B</td><td>B</td><td>B</td><td>a</td></tr> <tr><td>B</td><td>B</td><td>B</td><td>B</td><td>B</td><td>B</td><td>B</td><td>B</td><td>B</td><td>B</td><td>B</td><td>B</td><td>B</td><td>B</td><td>B</td><td>B</td><td>B</td><td>B</td><td>B</td><td>B</td><td>B</td><td>B</td><td>B</td><td>B</td><td>B</td><td>b</td></tr> <tr><td>B</td><td>B</td><td>B</td><td>B</td><td>B</td><td>B</td><td>B</td><td>B</td><td>B</td><td>B</td><td>B</td><td>B</td><td>B</td><td>B</td><td>B</td><td>B</td><td>B</td><td>B</td><td>B</td><td>B</td><td>B</td><td>B</td><td>B</td><td>B</td><td>B</td><td>c</td></tr> <tr><td>B</td><td>B</td><td>B</td><td>B</td><td>B</td><td>B</td><td>B</td><td>B</td><td>B</td><td>B</td><td>B</td><td>B</td><td>B</td><td>B</td><td>B</td><td>B</td><td>B</td><td>B</td><td>B</td><td>B</td><td>B</td><td>B</td><td>B</td><td>B</td><td>B</td><td>d</td></tr> <tr><td>B</td><td>B</td><td>B</td><td>B</td><td>B</td><td>B</td><td>B</td><td>B</td><td>B</td><td>B</td><td>B</td><td>B</td><td>B</td><td>B</td><td>B</td><td>B</td><td>B</td><td>B</td><td>B</td><td>B</td><td>B</td><td>B</td><td>B</td><td>B</td><td>B</td><td>e</td></tr> <tr><td>C</td><td>C</td><td>C</td><td>C</td><td>C</td><td>C</td><td>C</td><td>C</td><td>C</td><td>C</td><td>C</td><td>C</td><td>C</td><td>C</td><td>C</td><td>C</td><td>C</td><td>C</td><td>C</td><td>C</td><td>C</td><td>C</td><td>C</td><td>C</td><td>C</td><td>f</td></tr> </table>	25	24	23	22	21	20	19	18	17	16	15	14	13	12	11	10	9	8	7	6	5	4	3	2	1	C	C	C	C	C	C	C	C	C	C	C	C	C	C	C	C	C	C	C	C	C	C	C	C	C	z	B	B	B	B	B	B	B	B	B	B	B	B	B	B	B	B	B	B	B	B	B	B	B	B	B	a	B	B	B	B	B	B	B	B	B	B	B	B	B	B	B	B	B	B	B	B	B	B	B	B	B	b	B	B	B	B	B	B	B	B	B	B	B	B	B	B	B	B	B	B	B	B	B	B	B	B	B	c	B	B	B	B	B	B	B	B	B	B	B	B	B	B	B	B	B	B	B	B	B	B	B	B	B	d	B	B	B	B	B	B	B	B	B	B	B	B	B	B	B	B	B	B	B	B	B	B	B	B	B	e	C	C	C	C	C	C	C	C	C	C	C	C	C	C	C	C	C	C	C	C	C	C	C	C	C	f	154	2	17 7200 154 005 002
25	24	23	22	21	20	19	18	17	16	15	14	13	12	11	10	9	8	7	6	5	4	3	2	1																																																																																																																																																																																										
C	C	C	C	C	C	C	C	C	C	C	C	C	C	C	C	C	C	C	C	C	C	C	C	C	z																																																																																																																																																																																									
B	B	B	B	B	B	B	B	B	B	B	B	B	B	B	B	B	B	B	B	B	B	B	B	B	a																																																																																																																																																																																									
B	B	B	B	B	B	B	B	B	B	B	B	B	B	B	B	B	B	B	B	B	B	B	B	B	b																																																																																																																																																																																									
B	B	B	B	B	B	B	B	B	B	B	B	B	B	B	B	B	B	B	B	B	B	B	B	B	c																																																																																																																																																																																									
B	B	B	B	B	B	B	B	B	B	B	B	B	B	B	B	B	B	B	B	B	B	B	B	B	d																																																																																																																																																																																									
B	B	B	B	B	B	B	B	B	B	B	B	B	B	B	B	B	B	B	B	B	B	B	B	B	e																																																																																																																																																																																									
C	C	C	C	C	C	C	C	C	C	C	C	C	C	C	C	C	C	C	C	C	C	C	C	C	f																																																																																																																																																																																									
<p align="center">CompactPCI® Hot Swap</p> <table border="1"> <tr><td>25</td><td>24</td><td>23</td><td>22</td><td>21</td><td>20</td><td>19</td><td>18</td><td>17</td><td>16</td><td>15</td><td>14</td><td>13</td><td>12</td><td>11</td><td>10</td><td>9</td><td>8</td><td>7</td><td>6</td><td>5</td><td>4</td><td>3</td><td>2</td><td>1</td></tr> <tr><td>C</td><td>C</td><td>C</td><td>C</td><td>C</td><td>C</td><td>C</td><td>C</td><td>C</td><td>C</td><td>C</td><td>C</td><td>C</td><td>C</td><td>C</td><td>C</td><td>C</td><td>C</td><td>C</td><td>C</td><td>C</td><td>C</td><td>C</td><td>C</td><td>C</td><td>z</td></tr> <tr><td>B</td><td>B</td><td>B</td><td>B</td><td>B</td><td>B</td><td>B</td><td>B</td><td>B</td><td>B</td><td>B</td><td>B</td><td>B</td><td>B</td><td>B</td><td>B</td><td>B</td><td>B</td><td>B</td><td>B</td><td>B</td><td>B</td><td>B</td><td>B</td><td>B</td><td>a</td></tr> <tr><td>B</td><td>B</td><td>B</td><td>B</td><td>B</td><td>B</td><td>B</td><td>B</td><td>B</td><td>B</td><td>B</td><td>B</td><td>B</td><td>B</td><td>B</td><td>B</td><td>B</td><td>B</td><td>B</td><td>B</td><td>B</td><td>B</td><td>B</td><td>B</td><td>B</td><td>b</td></tr> <tr><td>B</td><td>B</td><td>B</td><td>C</td><td>B</td><td>C</td><td>B</td><td>C</td><td>B</td><td>B</td><td>B</td><td>B</td><td>B</td><td>B</td><td>B</td><td>B</td><td>B</td><td>B</td><td>B</td><td>B</td><td>B</td><td>B</td><td>C</td><td>B</td><td>C</td><td>c</td></tr> <tr><td>B</td><td>B</td><td>C</td><td>B</td><td>C</td><td>B</td><td>C</td><td>B</td><td>C</td><td>B</td><td>B</td><td>B</td><td>B</td><td>B</td><td>B</td><td>B</td><td>B</td><td>B</td><td>B</td><td>B</td><td>B</td><td>A</td><td>B</td><td>C</td><td>B</td><td>d</td></tr> <tr><td>B</td><td>B</td><td>B</td><td>B</td><td>B</td><td>B</td><td>B</td><td>B</td><td>B</td><td>B</td><td>B</td><td>B</td><td>B</td><td>B</td><td>B</td><td>B</td><td>B</td><td>B</td><td>B</td><td>B</td><td>B</td><td>B</td><td>B</td><td>B</td><td>B</td><td>e</td></tr> <tr><td>C</td><td>C</td><td>C</td><td>C</td><td>C</td><td>C</td><td>C</td><td>C</td><td>C</td><td>C</td><td>C</td><td>C</td><td>C</td><td>C</td><td>C</td><td>C</td><td>C</td><td>C</td><td>C</td><td>C</td><td>C</td><td>C</td><td>C</td><td>C</td><td>C</td><td>f</td></tr> </table>	25	24	23	22	21	20	19	18	17	16	15	14	13	12	11	10	9	8	7	6	5	4	3	2	1	C	C	C	C	C	C	C	C	C	C	C	C	C	C	C	C	C	C	C	C	C	C	C	C	C	z	B	B	B	B	B	B	B	B	B	B	B	B	B	B	B	B	B	B	B	B	B	B	B	B	B	a	B	B	B	B	B	B	B	B	B	B	B	B	B	B	B	B	B	B	B	B	B	B	B	B	B	b	B	B	B	C	B	C	B	C	B	B	B	B	B	B	B	B	B	B	B	B	B	B	C	B	C	c	B	B	C	B	C	B	C	B	C	B	B	B	B	B	B	B	B	B	B	B	B	A	B	C	B	d	B	B	B	B	B	B	B	B	B	B	B	B	B	B	B	B	B	B	B	B	B	B	B	B	B	e	C	C	C	C	C	C	C	C	C	C	C	C	C	C	C	C	C	C	C	C	C	C	C	C	C	f	154	2	17 7200 154 006 002
25	24	23	22	21	20	19	18	17	16	15	14	13	12	11	10	9	8	7	6	5	4	3	2	1																																																																																																																																																																																										
C	C	C	C	C	C	C	C	C	C	C	C	C	C	C	C	C	C	C	C	C	C	C	C	C	z																																																																																																																																																																																									
B	B	B	B	B	B	B	B	B	B	B	B	B	B	B	B	B	B	B	B	B	B	B	B	B	a																																																																																																																																																																																									
B	B	B	B	B	B	B	B	B	B	B	B	B	B	B	B	B	B	B	B	B	B	B	B	B	b																																																																																																																																																																																									
B	B	B	C	B	C	B	C	B	B	B	B	B	B	B	B	B	B	B	B	B	B	C	B	C	c																																																																																																																																																																																									
B	B	C	B	C	B	C	B	C	B	B	B	B	B	B	B	B	B	B	B	B	A	B	C	B	d																																																																																																																																																																																									
B	B	B	B	B	B	B	B	B	B	B	B	B	B	B	B	B	B	B	B	B	B	B	B	B	e																																																																																																																																																																																									
C	C	C	C	C	C	C	C	C	C	C	C	C	C	C	C	C	C	C	C	C	C	C	C	C	f																																																																																																																																																																																									
<p align="center">CompactPCI® Computer Telephony</p> <table border="1"> <tr><td>25</td><td>24</td><td>23</td><td>22</td><td>21</td><td>20</td><td>19</td><td>18</td><td>17</td><td>16</td><td>15</td><td>14</td><td>13</td><td>12</td><td>11</td><td>10</td><td>9</td><td>8</td><td>7</td><td>6</td><td>5</td><td>4</td><td>3</td><td>2</td><td>1</td></tr> <tr><td>B</td><td>B</td><td>B</td><td>B</td><td>B</td><td>B</td><td>B</td><td>B</td><td>B</td><td>B</td><td>B</td><td>B</td><td>B</td><td>B</td><td>B</td><td>B</td><td>B</td><td>B</td><td>B</td><td>B</td><td>B</td><td>B</td><td>B</td><td>B</td><td>B</td><td>z</td></tr> <tr><td>B</td><td>B</td><td>B</td><td>B</td><td>B</td><td>B</td><td>B</td><td>B</td><td>B</td><td>B</td><td>B</td><td>B</td><td>B</td><td>B</td><td>B</td><td>B</td><td>B</td><td>B</td><td>B</td><td>B</td><td>B</td><td>B</td><td>B</td><td>B</td><td>B</td><td>a</td></tr> <tr><td>B</td><td>B</td><td>B</td><td>B</td><td>B</td><td>B</td><td>B</td><td>B</td><td>B</td><td>B</td><td>B</td><td>B</td><td>B</td><td>B</td><td>B</td><td>B</td><td>B</td><td>B</td><td>B</td><td>B</td><td>B</td><td>B</td><td>B</td><td>B</td><td>B</td><td>b</td></tr> <tr><td>B</td><td>B</td><td>C</td><td>C</td><td>C</td><td>C</td><td>C</td><td>C</td><td>C</td><td>C</td><td>C</td><td>C</td><td>C</td><td>C</td><td>C</td><td>C</td><td>C</td><td>C</td><td>C</td><td>C</td><td>C</td><td>B</td><td>B</td><td>B</td><td>B</td><td>c</td></tr> <tr><td>B</td><td>C</td><td>B</td><td>B</td><td>B</td><td>B</td><td>B</td><td>B</td><td>B</td><td>B</td><td>B</td><td>B</td><td>B</td><td>B</td><td>B</td><td>B</td><td>B</td><td>B</td><td>B</td><td>B</td><td>B</td><td>C</td><td>B</td><td>B</td><td>B</td><td>d</td></tr> <tr><td>C</td><td>C</td><td>C</td><td>C</td><td>C</td><td>C</td><td>C</td><td>C</td><td>C</td><td>C</td><td>C</td><td>C</td><td>C</td><td>C</td><td>C</td><td>C</td><td>C</td><td>C</td><td>C</td><td>C</td><td>C</td><td>C</td><td>C</td><td>C</td><td>C</td><td>e</td></tr> <tr><td>C</td><td>C</td><td>C</td><td>C</td><td>C</td><td>C</td><td>C</td><td>C</td><td>C</td><td>C</td><td>C</td><td>C</td><td>C</td><td>C</td><td>C</td><td>C</td><td>C</td><td>C</td><td>C</td><td>C</td><td>C</td><td>C</td><td>C</td><td>C</td><td>C</td><td>f</td></tr> </table>	25	24	23	22	21	20	19	18	17	16	15	14	13	12	11	10	9	8	7	6	5	4	3	2	1	B	B	B	B	B	B	B	B	B	B	B	B	B	B	B	B	B	B	B	B	B	B	B	B	B	z	B	B	B	B	B	B	B	B	B	B	B	B	B	B	B	B	B	B	B	B	B	B	B	B	B	a	B	B	B	B	B	B	B	B	B	B	B	B	B	B	B	B	B	B	B	B	B	B	B	B	B	b	B	B	C	C	C	C	C	C	C	C	C	C	C	C	C	C	C	C	C	C	C	B	B	B	B	c	B	C	B	B	B	B	B	B	B	B	B	B	B	B	B	B	B	B	B	B	B	C	B	B	B	d	C	C	C	C	C	C	C	C	C	C	C	C	C	C	C	C	C	C	C	C	C	C	C	C	C	e	C	C	C	C	C	C	C	C	C	C	C	C	C	C	C	C	C	C	C	C	C	C	C	C	C	f	100	2	17 7200 100 008 002
25	24	23	22	21	20	19	18	17	16	15	14	13	12	11	10	9	8	7	6	5	4	3	2	1																																																																																																																																																																																										
B	B	B	B	B	B	B	B	B	B	B	B	B	B	B	B	B	B	B	B	B	B	B	B	B	z																																																																																																																																																																																									
B	B	B	B	B	B	B	B	B	B	B	B	B	B	B	B	B	B	B	B	B	B	B	B	B	a																																																																																																																																																																																									
B	B	B	B	B	B	B	B	B	B	B	B	B	B	B	B	B	B	B	B	B	B	B	B	B	b																																																																																																																																																																																									
B	B	C	C	C	C	C	C	C	C	C	C	C	C	C	C	C	C	C	C	C	B	B	B	B	c																																																																																																																																																																																									
B	C	B	B	B	B	B	B	B	B	B	B	B	B	B	B	B	B	B	B	B	C	B	B	B	d																																																																																																																																																																																									
C	C	C	C	C	C	C	C	C	C	C	C	C	C	C	C	C	C	C	C	C	C	C	C	C	e																																																																																																																																																																																									
C	C	C	C	C	C	C	C	C	C	C	C	C	C	C	C	C	C	C	C	C	C	C	C	C	f																																																																																																																																																																																									

Technical description and dimensions see page 32

AVX will custom load connectors with any combination of the contacts in the table on page 35. Complete the form on page 57 and fax it to the number shown.

Vertical Male

Series 7200 – Style B 25, 175 Contacts

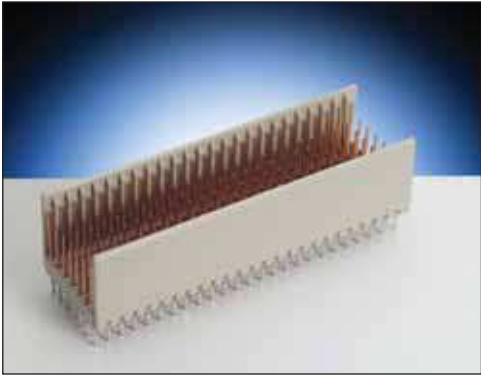

- Up to 125 signal contacts and 50 ground shield contacts in 5 or 5+2 rows of 25 positions
- Designed for gas tight press-fit installations
- This connector should be used in conjunction with Style A connector
- Twelve different contact styles are available for customizing connector to exact specifications (complete form on page 57)



DIMENSIONS: millimeters (inches)

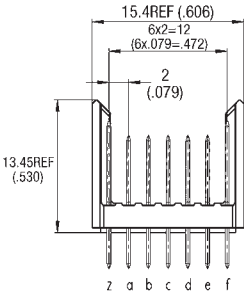
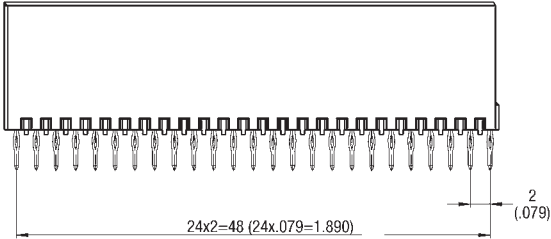

LAYOUT

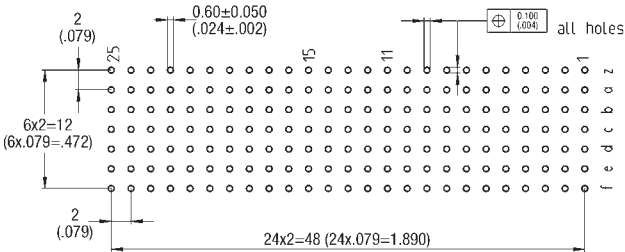
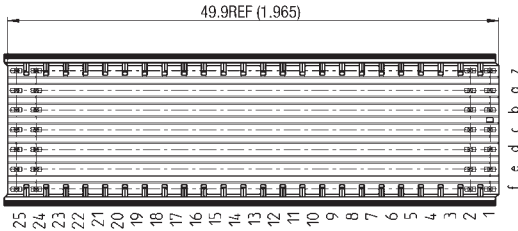

Vertical Male

Style B 25 – 175 Contacts



Pin Loading	Contacts	Performance Class	Part Number
	175	2	17 7200 175 100 002
	175	2	17 7200 175 101 002
	175	2	17 7200 175 102 005
	175	2	17 7200 175 103 005
	175	2	17 7200 175 104 005
	125	2	17 7200 125 100 012

Technical description and dimensions see page 34

AVX will custom load connectors with any combination of the contacts in the table below. Complete the form on page 57 and fax it to the number shown.

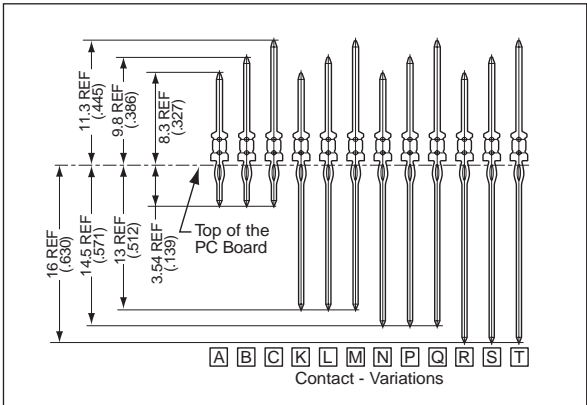

Vertical Male

Series 7200 – Style B 22, 154 Contacts



- Up to 110 signal contacts and 44 ground shield contacts in 5 or 5+2 rows of 22 positions
- Designed for gas tight press-fit installations
- Used in position P2 and P5 of the CompactPCI® specification
- Should be used in conjunction with a type A or AB connector
- Twelve different contact styles are available for customizing connector to exact specifications (complete form on page 57)



DIMENSIONS: millimeters (inches)

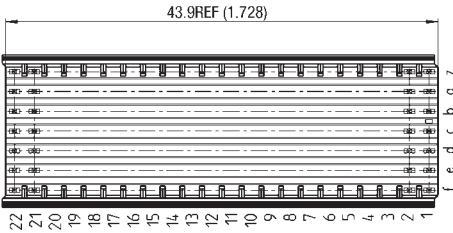
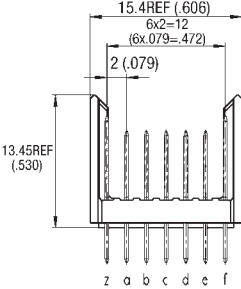
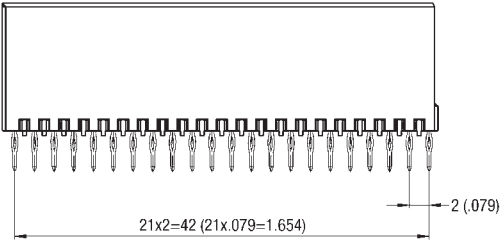

LAYOUT

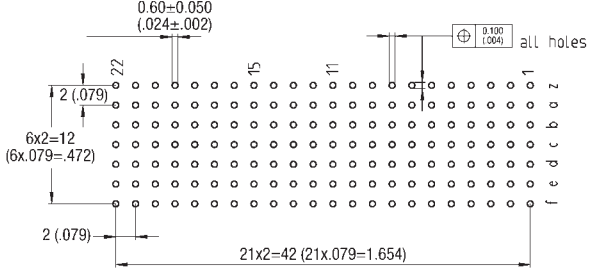

Vertical Male

Style B 22 – 154 Contacts



Pin Loading	Contacts	Performance Class	Part Number																																																																																																																																																																																							
<table border="1"> <tr><td>22</td><td>21</td><td>20</td><td>19</td><td>18</td><td>17</td><td>16</td><td>15</td><td>14</td><td>13</td><td>12</td><td>11</td><td>10</td><td>9</td><td>8</td><td>7</td><td>6</td><td>5</td><td>4</td><td>3</td><td>2</td><td>1</td></tr> <tr><td>C</td><td>C</td><td>C</td><td>C</td><td>C</td><td>C</td><td>C</td><td>C</td><td>C</td><td>C</td><td>C</td><td>C</td><td>C</td><td>C</td><td>C</td><td>C</td><td>C</td><td>C</td><td>C</td><td>C</td><td>C</td><td>C</td><td>z</td></tr> <tr><td>A</td><td>A</td><td>A</td><td>A</td><td>A</td><td>A</td><td>A</td><td>A</td><td>A</td><td>A</td><td>A</td><td>A</td><td>A</td><td>A</td><td>A</td><td>A</td><td>A</td><td>A</td><td>A</td><td>A</td><td>A</td><td>A</td><td>a</td></tr> <tr><td>A</td><td>A</td><td>A</td><td>A</td><td>A</td><td>A</td><td>A</td><td>A</td><td>A</td><td>A</td><td>A</td><td>A</td><td>A</td><td>A</td><td>A</td><td>A</td><td>A</td><td>A</td><td>A</td><td>A</td><td>A</td><td>A</td><td>b</td></tr> <tr><td>A</td><td>A</td><td>A</td><td>A</td><td>A</td><td>A</td><td>A</td><td>A</td><td>A</td><td>A</td><td>A</td><td>A</td><td>A</td><td>A</td><td>A</td><td>A</td><td>A</td><td>A</td><td>A</td><td>A</td><td>A</td><td>A</td><td>c</td></tr> <tr><td>A</td><td>A</td><td>A</td><td>A</td><td>A</td><td>A</td><td>A</td><td>A</td><td>A</td><td>A</td><td>A</td><td>A</td><td>A</td><td>A</td><td>A</td><td>A</td><td>A</td><td>A</td><td>A</td><td>A</td><td>A</td><td>A</td><td>d</td></tr> <tr><td>A</td><td>A</td><td>A</td><td>A</td><td>A</td><td>A</td><td>A</td><td>A</td><td>A</td><td>A</td><td>A</td><td>A</td><td>A</td><td>A</td><td>A</td><td>A</td><td>A</td><td>A</td><td>A</td><td>A</td><td>A</td><td>A</td><td>e</td></tr> <tr><td>C</td><td>C</td><td>C</td><td>C</td><td>C</td><td>C</td><td>C</td><td>C</td><td>C</td><td>C</td><td>C</td><td>C</td><td>C</td><td>C</td><td>C</td><td>C</td><td>C</td><td>C</td><td>C</td><td>C</td><td>C</td><td>C</td><td>f</td></tr> </table>	22	21	20	19	18	17	16	15	14	13	12	11	10	9	8	7	6	5	4	3	2	1	C	C	C	C	C	C	C	C	C	C	C	C	C	C	C	C	C	C	C	C	C	C	z	A	A	A	A	A	A	A	A	A	A	A	A	A	A	A	A	A	A	A	A	A	A	a	A	A	A	A	A	A	A	A	A	A	A	A	A	A	A	A	A	A	A	A	A	A	b	A	A	A	A	A	A	A	A	A	A	A	A	A	A	A	A	A	A	A	A	A	A	c	A	A	A	A	A	A	A	A	A	A	A	A	A	A	A	A	A	A	A	A	A	A	d	A	A	A	A	A	A	A	A	A	A	A	A	A	A	A	A	A	A	A	A	A	A	e	C	C	C	C	C	C	C	C	C	C	C	C	C	C	C	C	C	C	C	C	C	C	f	154	2	17 7200 154 200 002
22	21	20	19	18	17	16	15	14	13	12	11	10	9	8	7	6	5	4	3	2	1																																																																																																																																																																					
C	C	C	C	C	C	C	C	C	C	C	C	C	C	C	C	C	C	C	C	C	C	z																																																																																																																																																																				
A	A	A	A	A	A	A	A	A	A	A	A	A	A	A	A	A	A	A	A	A	A	a																																																																																																																																																																				
A	A	A	A	A	A	A	A	A	A	A	A	A	A	A	A	A	A	A	A	A	A	b																																																																																																																																																																				
A	A	A	A	A	A	A	A	A	A	A	A	A	A	A	A	A	A	A	A	A	A	c																																																																																																																																																																				
A	A	A	A	A	A	A	A	A	A	A	A	A	A	A	A	A	A	A	A	A	A	d																																																																																																																																																																				
A	A	A	A	A	A	A	A	A	A	A	A	A	A	A	A	A	A	A	A	A	A	e																																																																																																																																																																				
C	C	C	C	C	C	C	C	C	C	C	C	C	C	C	C	C	C	C	C	C	C	f																																																																																																																																																																				
<table border="1"> <tr><td>22</td><td>21</td><td>20</td><td>19</td><td>18</td><td>17</td><td>16</td><td>15</td><td>14</td><td>13</td><td>12</td><td>11</td><td>10</td><td>9</td><td>8</td><td>7</td><td>6</td><td>5</td><td>4</td><td>3</td><td>2</td><td>1</td></tr> <tr><td>C</td><td>C</td><td>C</td><td>C</td><td>C</td><td>C</td><td>C</td><td>C</td><td>C</td><td>C</td><td>C</td><td>C</td><td>C</td><td>C</td><td>C</td><td>C</td><td>C</td><td>C</td><td>C</td><td>C</td><td>C</td><td>C</td><td>z</td></tr> <tr><td>B</td><td>B</td><td>B</td><td>B</td><td>B</td><td>B</td><td>B</td><td>B</td><td>B</td><td>B</td><td>B</td><td>B</td><td>B</td><td>B</td><td>B</td><td>B</td><td>B</td><td>B</td><td>B</td><td>B</td><td>B</td><td>B</td><td>a</td></tr> <tr><td>B</td><td>B</td><td>B</td><td>B</td><td>B</td><td>B</td><td>B</td><td>B</td><td>B</td><td>B</td><td>B</td><td>B</td><td>B</td><td>B</td><td>B</td><td>B</td><td>B</td><td>B</td><td>B</td><td>B</td><td>B</td><td>B</td><td>b</td></tr> <tr><td>B</td><td>B</td><td>B</td><td>B</td><td>B</td><td>B</td><td>B</td><td>B</td><td>B</td><td>B</td><td>B</td><td>B</td><td>B</td><td>B</td><td>B</td><td>B</td><td>B</td><td>B</td><td>B</td><td>B</td><td>B</td><td>B</td><td>c</td></tr> <tr><td>B</td><td>B</td><td>B</td><td>B</td><td>B</td><td>B</td><td>B</td><td>B</td><td>B</td><td>B</td><td>B</td><td>B</td><td>B</td><td>B</td><td>B</td><td>B</td><td>B</td><td>B</td><td>B</td><td>B</td><td>B</td><td>B</td><td>d</td></tr> <tr><td>B</td><td>B</td><td>B</td><td>B</td><td>B</td><td>B</td><td>B</td><td>B</td><td>B</td><td>B</td><td>B</td><td>B</td><td>B</td><td>B</td><td>B</td><td>B</td><td>B</td><td>B</td><td>B</td><td>B</td><td>B</td><td>B</td><td>e</td></tr> <tr><td>C</td><td>C</td><td>C</td><td>C</td><td>C</td><td>C</td><td>C</td><td>C</td><td>C</td><td>C</td><td>C</td><td>C</td><td>C</td><td>C</td><td>C</td><td>C</td><td>C</td><td>C</td><td>C</td><td>C</td><td>C</td><td>C</td><td>f</td></tr> </table>	22	21	20	19	18	17	16	15	14	13	12	11	10	9	8	7	6	5	4	3	2	1	C	C	C	C	C	C	C	C	C	C	C	C	C	C	C	C	C	C	C	C	C	C	z	B	B	B	B	B	B	B	B	B	B	B	B	B	B	B	B	B	B	B	B	B	B	a	B	B	B	B	B	B	B	B	B	B	B	B	B	B	B	B	B	B	B	B	B	B	b	B	B	B	B	B	B	B	B	B	B	B	B	B	B	B	B	B	B	B	B	B	B	c	B	B	B	B	B	B	B	B	B	B	B	B	B	B	B	B	B	B	B	B	B	B	d	B	B	B	B	B	B	B	B	B	B	B	B	B	B	B	B	B	B	B	B	B	B	e	C	C	C	C	C	C	C	C	C	C	C	C	C	C	C	C	C	C	C	C	C	C	f	154	2	17 7200 154 201 002
22	21	20	19	18	17	16	15	14	13	12	11	10	9	8	7	6	5	4	3	2	1																																																																																																																																																																					
C	C	C	C	C	C	C	C	C	C	C	C	C	C	C	C	C	C	C	C	C	C	z																																																																																																																																																																				
B	B	B	B	B	B	B	B	B	B	B	B	B	B	B	B	B	B	B	B	B	B	a																																																																																																																																																																				
B	B	B	B	B	B	B	B	B	B	B	B	B	B	B	B	B	B	B	B	B	B	b																																																																																																																																																																				
B	B	B	B	B	B	B	B	B	B	B	B	B	B	B	B	B	B	B	B	B	B	c																																																																																																																																																																				
B	B	B	B	B	B	B	B	B	B	B	B	B	B	B	B	B	B	B	B	B	B	d																																																																																																																																																																				
B	B	B	B	B	B	B	B	B	B	B	B	B	B	B	B	B	B	B	B	B	B	e																																																																																																																																																																				
C	C	C	C	C	C	C	C	C	C	C	C	C	C	C	C	C	C	C	C	C	C	f																																																																																																																																																																				
<p>P2/ P5 CompactPCI®</p> <table border="1"> <tr><td>22</td><td>21</td><td>20</td><td>19</td><td>18</td><td>17</td><td>16</td><td>15</td><td>14</td><td>13</td><td>12</td><td>11</td><td>10</td><td>9</td><td>8</td><td>7</td><td>6</td><td>5</td><td>4</td><td>3</td><td>2</td><td>1</td></tr> <tr><td>T</td><td>T</td><td>T</td><td>T</td><td>T</td><td>T</td><td>T</td><td>T</td><td>T</td><td>T</td><td>T</td><td>T</td><td>T</td><td>T</td><td>T</td><td>T</td><td>T</td><td>T</td><td>T</td><td>T</td><td>T</td><td>T</td><td>z</td></tr> <tr><td>P</td><td>P</td><td>P</td><td>P</td><td>P</td><td>P</td><td>P</td><td>P</td><td>P</td><td>P</td><td>P</td><td>P</td><td>P</td><td>P</td><td>P</td><td>P</td><td>P</td><td>P</td><td>P</td><td>P</td><td>P</td><td>P</td><td>a</td></tr> <tr><td>P</td><td>P</td><td>P</td><td>P</td><td>P</td><td>P</td><td>P</td><td>P</td><td>P</td><td>P</td><td>P</td><td>P</td><td>P</td><td>P</td><td>P</td><td>P</td><td>P</td><td>P</td><td>P</td><td>P</td><td>P</td><td>P</td><td>b</td></tr> <tr><td>P</td><td>P</td><td>P</td><td>P</td><td>P</td><td>P</td><td>P</td><td>P</td><td>P</td><td>P</td><td>P</td><td>P</td><td>P</td><td>P</td><td>P</td><td>P</td><td>P</td><td>P</td><td>P</td><td>P</td><td>P</td><td>P</td><td>c</td></tr> <tr><td>P</td><td>P</td><td>P</td><td>P</td><td>P</td><td>P</td><td>P</td><td>P</td><td>P</td><td>P</td><td>P</td><td>P</td><td>P</td><td>P</td><td>P</td><td>P</td><td>P</td><td>P</td><td>P</td><td>P</td><td>P</td><td>P</td><td>d</td></tr> <tr><td>P</td><td>P</td><td>P</td><td>P</td><td>P</td><td>P</td><td>P</td><td>P</td><td>P</td><td>P</td><td>P</td><td>P</td><td>P</td><td>P</td><td>P</td><td>P</td><td>P</td><td>P</td><td>P</td><td>P</td><td>P</td><td>P</td><td>e</td></tr> <tr><td>T</td><td>T</td><td>T</td><td>T</td><td>T</td><td>T</td><td>T</td><td>T</td><td>T</td><td>T</td><td>T</td><td>T</td><td>T</td><td>T</td><td>T</td><td>T</td><td>T</td><td>T</td><td>T</td><td>T</td><td>T</td><td>T</td><td>f</td></tr> </table>	22	21	20	19	18	17	16	15	14	13	12	11	10	9	8	7	6	5	4	3	2	1	T	T	T	T	T	T	T	T	T	T	T	T	T	T	T	T	T	T	T	T	T	T	z	P	P	P	P	P	P	P	P	P	P	P	P	P	P	P	P	P	P	P	P	P	P	a	P	P	P	P	P	P	P	P	P	P	P	P	P	P	P	P	P	P	P	P	P	P	b	P	P	P	P	P	P	P	P	P	P	P	P	P	P	P	P	P	P	P	P	P	P	c	P	P	P	P	P	P	P	P	P	P	P	P	P	P	P	P	P	P	P	P	P	P	d	P	P	P	P	P	P	P	P	P	P	P	P	P	P	P	P	P	P	P	P	P	P	e	T	T	T	T	T	T	T	T	T	T	T	T	T	T	T	T	T	T	T	T	T	T	f	154	2	17 7200 154 202 005
22	21	20	19	18	17	16	15	14	13	12	11	10	9	8	7	6	5	4	3	2	1																																																																																																																																																																					
T	T	T	T	T	T	T	T	T	T	T	T	T	T	T	T	T	T	T	T	T	T	z																																																																																																																																																																				
P	P	P	P	P	P	P	P	P	P	P	P	P	P	P	P	P	P	P	P	P	P	a																																																																																																																																																																				
P	P	P	P	P	P	P	P	P	P	P	P	P	P	P	P	P	P	P	P	P	P	b																																																																																																																																																																				
P	P	P	P	P	P	P	P	P	P	P	P	P	P	P	P	P	P	P	P	P	P	c																																																																																																																																																																				
P	P	P	P	P	P	P	P	P	P	P	P	P	P	P	P	P	P	P	P	P	P	d																																																																																																																																																																				
P	P	P	P	P	P	P	P	P	P	P	P	P	P	P	P	P	P	P	P	P	P	e																																																																																																																																																																				
T	T	T	T	T	T	T	T	T	T	T	T	T	T	T	T	T	T	T	T	T	T	f																																																																																																																																																																				
<p>P2/ P5 CompactPCI®</p> <table border="1"> <tr><td>22</td><td>21</td><td>20</td><td>19</td><td>18</td><td>17</td><td>16</td><td>15</td><td>14</td><td>13</td><td>12</td><td>11</td><td>10</td><td>9</td><td>8</td><td>7</td><td>6</td><td>5</td><td>4</td><td>3</td><td>2</td><td>1</td></tr> <tr><td>T</td><td>T</td><td>T</td><td>T</td><td>T</td><td>T</td><td>T</td><td>T</td><td>T</td><td>T</td><td>T</td><td>T</td><td>T</td><td>T</td><td>T</td><td>T</td><td>T</td><td>T</td><td>T</td><td>T</td><td>T</td><td>T</td><td>z</td></tr> <tr><td>R</td><td>R</td><td>R</td><td>R</td><td>R</td><td>R</td><td>R</td><td>R</td><td>R</td><td>R</td><td>R</td><td>R</td><td>R</td><td>R</td><td>R</td><td>R</td><td>R</td><td>R</td><td>R</td><td>R</td><td>R</td><td>R</td><td>a</td></tr> <tr><td>R</td><td>R</td><td>R</td><td>R</td><td>R</td><td>R</td><td>R</td><td>R</td><td>R</td><td>R</td><td>R</td><td>R</td><td>R</td><td>R</td><td>R</td><td>R</td><td>R</td><td>R</td><td>R</td><td>R</td><td>R</td><td>R</td><td>b</td></tr> <tr><td>R</td><td>R</td><td>R</td><td>R</td><td>R</td><td>R</td><td>R</td><td>R</td><td>R</td><td>R</td><td>R</td><td>R</td><td>R</td><td>R</td><td>R</td><td>R</td><td>R</td><td>R</td><td>R</td><td>R</td><td>R</td><td>R</td><td>c</td></tr> <tr><td>R</td><td>R</td><td>R</td><td>R</td><td>R</td><td>R</td><td>R</td><td>R</td><td>R</td><td>R</td><td>R</td><td>R</td><td>R</td><td>R</td><td>R</td><td>R</td><td>R</td><td>R</td><td>R</td><td>R</td><td>R</td><td>R</td><td>d</td></tr> <tr><td>R</td><td>R</td><td>R</td><td>R</td><td>R</td><td>R</td><td>R</td><td>R</td><td>R</td><td>R</td><td>R</td><td>R</td><td>R</td><td>R</td><td>R</td><td>R</td><td>R</td><td>R</td><td>R</td><td>R</td><td>R</td><td>R</td><td>e</td></tr> <tr><td>T</td><td>T</td><td>T</td><td>T</td><td>T</td><td>T</td><td>T</td><td>T</td><td>T</td><td>T</td><td>T</td><td>T</td><td>T</td><td>T</td><td>T</td><td>T</td><td>T</td><td>T</td><td>T</td><td>T</td><td>T</td><td>T</td><td>f</td></tr> </table>	22	21	20	19	18	17	16	15	14	13	12	11	10	9	8	7	6	5	4	3	2	1	T	T	T	T	T	T	T	T	T	T	T	T	T	T	T	T	T	T	T	T	T	T	z	R	R	R	R	R	R	R	R	R	R	R	R	R	R	R	R	R	R	R	R	R	R	a	R	R	R	R	R	R	R	R	R	R	R	R	R	R	R	R	R	R	R	R	R	R	b	R	R	R	R	R	R	R	R	R	R	R	R	R	R	R	R	R	R	R	R	R	R	c	R	R	R	R	R	R	R	R	R	R	R	R	R	R	R	R	R	R	R	R	R	R	d	R	R	R	R	R	R	R	R	R	R	R	R	R	R	R	R	R	R	R	R	R	R	e	T	T	T	T	T	T	T	T	T	T	T	T	T	T	T	T	T	T	T	T	T	T	f	154	2	17 7200 154 203 005
22	21	20	19	18	17	16	15	14	13	12	11	10	9	8	7	6	5	4	3	2	1																																																																																																																																																																					
T	T	T	T	T	T	T	T	T	T	T	T	T	T	T	T	T	T	T	T	T	T	z																																																																																																																																																																				
R	R	R	R	R	R	R	R	R	R	R	R	R	R	R	R	R	R	R	R	R	R	a																																																																																																																																																																				
R	R	R	R	R	R	R	R	R	R	R	R	R	R	R	R	R	R	R	R	R	R	b																																																																																																																																																																				
R	R	R	R	R	R	R	R	R	R	R	R	R	R	R	R	R	R	R	R	R	R	c																																																																																																																																																																				
R	R	R	R	R	R	R	R	R	R	R	R	R	R	R	R	R	R	R	R	R	R	d																																																																																																																																																																				
R	R	R	R	R	R	R	R	R	R	R	R	R	R	R	R	R	R	R	R	R	R	e																																																																																																																																																																				
T	T	T	T	T	T	T	T	T	T	T	T	T	T	T	T	T	T	T	T	T	T	f																																																																																																																																																																				
<p>P2/ P5 CompactPCI®</p> <table border="1"> <tr><td>22</td><td>21</td><td>20</td><td>19</td><td>18</td><td>17</td><td>16</td><td>15</td><td>14</td><td>13</td><td>12</td><td>11</td><td>10</td><td>9</td><td>8</td><td>7</td><td>6</td><td>5</td><td>4</td><td>3</td><td>2</td><td>1</td></tr> <tr><td>T</td><td>T</td><td>T</td><td>T</td><td>T</td><td>T</td><td>T</td><td>T</td><td>T</td><td>T</td><td>T</td><td>T</td><td>T</td><td>T</td><td>T</td><td>T</td><td>T</td><td>T</td><td>T</td><td>T</td><td>T</td><td>T</td><td>z</td></tr> <tr><td>K</td><td>K</td><td>K</td><td>K</td><td>K</td><td>K</td><td>K</td><td>K</td><td>K</td><td>K</td><td>K</td><td>K</td><td>K</td><td>K</td><td>K</td><td>K</td><td>K</td><td>K</td><td>K</td><td>K</td><td>K</td><td>K</td><td>a</td></tr> <tr><td>K</td><td>K</td><td>K</td><td>K</td><td>K</td><td>K</td><td>K</td><td>K</td><td>K</td><td>K</td><td>K</td><td>K</td><td>K</td><td>K</td><td>K</td><td>K</td><td>K</td><td>K</td><td>K</td><td>K</td><td>K</td><td>K</td><td>b</td></tr> <tr><td>K</td><td>K</td><td>K</td><td>K</td><td>K</td><td>K</td><td>K</td><td>K</td><td>K</td><td>K</td><td>K</td><td>K</td><td>K</td><td>K</td><td>K</td><td>K</td><td>K</td><td>K</td><td>K</td><td>K</td><td>K</td><td>K</td><td>c</td></tr> <tr><td>K</td><td>K</td><td>K</td><td>K</td><td>K</td><td>K</td><td>K</td><td>K</td><td>K</td><td>K</td><td>K</td><td>K</td><td>K</td><td>K</td><td>K</td><td>K</td><td>K</td><td>K</td><td>K</td><td>K</td><td>K</td><td>K</td><td>d</td></tr> <tr><td>K</td><td>K</td><td>K</td><td>K</td><td>K</td><td>K</td><td>K</td><td>K</td><td>K</td><td>K</td><td>K</td><td>K</td><td>K</td><td>K</td><td>K</td><td>K</td><td>K</td><td>K</td><td>K</td><td>K</td><td>K</td><td>K</td><td>e</td></tr> <tr><td>T</td><td>T</td><td>T</td><td>T</td><td>T</td><td>T</td><td>T</td><td>T</td><td>T</td><td>T</td><td>T</td><td>T</td><td>T</td><td>T</td><td>T</td><td>T</td><td>T</td><td>T</td><td>T</td><td>T</td><td>T</td><td>T</td><td>f</td></tr> </table>	22	21	20	19	18	17	16	15	14	13	12	11	10	9	8	7	6	5	4	3	2	1	T	T	T	T	T	T	T	T	T	T	T	T	T	T	T	T	T	T	T	T	T	T	z	K	K	K	K	K	K	K	K	K	K	K	K	K	K	K	K	K	K	K	K	K	K	a	K	K	K	K	K	K	K	K	K	K	K	K	K	K	K	K	K	K	K	K	K	K	b	K	K	K	K	K	K	K	K	K	K	K	K	K	K	K	K	K	K	K	K	K	K	c	K	K	K	K	K	K	K	K	K	K	K	K	K	K	K	K	K	K	K	K	K	K	d	K	K	K	K	K	K	K	K	K	K	K	K	K	K	K	K	K	K	K	K	K	K	e	T	T	T	T	T	T	T	T	T	T	T	T	T	T	T	T	T	T	T	T	T	T	f	154	2	17 7200 154 204 005
22	21	20	19	18	17	16	15	14	13	12	11	10	9	8	7	6	5	4	3	2	1																																																																																																																																																																					
T	T	T	T	T	T	T	T	T	T	T	T	T	T	T	T	T	T	T	T	T	T	z																																																																																																																																																																				
K	K	K	K	K	K	K	K	K	K	K	K	K	K	K	K	K	K	K	K	K	K	a																																																																																																																																																																				
K	K	K	K	K	K	K	K	K	K	K	K	K	K	K	K	K	K	K	K	K	K	b																																																																																																																																																																				
K	K	K	K	K	K	K	K	K	K	K	K	K	K	K	K	K	K	K	K	K	K	c																																																																																																																																																																				
K	K	K	K	K	K	K	K	K	K	K	K	K	K	K	K	K	K	K	K	K	K	d																																																																																																																																																																				
K	K	K	K	K	K	K	K	K	K	K	K	K	K	K	K	K	K	K	K	K	K	e																																																																																																																																																																				
T	T	T	T	T	T	T	T	T	T	T	T	T	T	T	T	T	T	T	T	T	T	f																																																																																																																																																																				
<table border="1"> <tr><td>22</td><td>21</td><td>20</td><td>19</td><td>18</td><td>17</td><td>16</td><td>15</td><td>14</td><td>13</td><td>12</td><td>11</td><td>10</td><td>9</td><td>8</td><td>7</td><td>6</td><td>5</td><td>4</td><td>3</td><td>2</td><td>1</td></tr> <tr><td>T</td><td>T</td><td>T</td><td>T</td><td>T</td><td>T</td><td>T</td><td>T</td><td>T</td><td>T</td><td>T</td><td>T</td><td>T</td><td>T</td><td>T</td><td>T</td><td>T</td><td>T</td><td>T</td><td>T</td><td>T</td><td>T</td><td>z</td></tr> <tr><td>A</td><td>A</td><td>A</td><td>A</td><td>A</td><td>A</td><td>A</td><td>A</td><td>A</td><td>A</td><td>A</td><td>A</td><td>A</td><td>A</td><td>A</td><td>A</td><td>A</td><td>A</td><td>A</td><td>A</td><td>A</td><td>A</td><td>a</td></tr> <tr><td>A</td><td>A</td><td>A</td><td>A</td><td>A</td><td>A</td><td>A</td><td>A</td><td>A</td><td>A</td><td>A</td><td>A</td><td>A</td><td>A</td><td>A</td><td>A</td><td>A</td><td>A</td><td>A</td><td>A</td><td>A</td><td>A</td><td>b</td></tr> <tr><td>A</td><td>A</td><td>A</td><td>A</td><td>A</td><td>A</td><td>A</td><td>A</td><td>A</td><td>A</td><td>A</td><td>A</td><td>A</td><td>A</td><td>A</td><td>A</td><td>A</td><td>A</td><td>A</td><td>A</td><td>A</td><td>A</td><td>c</td></tr> <tr><td>A</td><td>A</td><td>A</td><td>A</td><td>A</td><td>A</td><td>A</td><td>A</td><td>A</td><td>A</td><td>A</td><td>A</td><td>A</td><td>A</td><td>A</td><td>A</td><td>A</td><td>A</td><td>A</td><td>A</td><td>A</td><td>A</td><td>d</td></tr> <tr><td>A</td><td>A</td><td>A</td><td>A</td><td>A</td><td>A</td><td>A</td><td>A</td><td>A</td><td>A</td><td>A</td><td>A</td><td>A</td><td>A</td><td>A</td><td>A</td><td>A</td><td>A</td><td>A</td><td>A</td><td>A</td><td>A</td><td>e</td></tr> <tr><td>T</td><td>T</td><td>T</td><td>T</td><td>T</td><td>T</td><td>T</td><td>T</td><td>T</td><td>T</td><td>T</td><td>T</td><td>T</td><td>T</td><td>T</td><td>T</td><td>T</td><td>T</td><td>T</td><td>T</td><td>T</td><td>T</td><td>f</td></tr> </table>	22	21	20	19	18	17	16	15	14	13	12	11	10	9	8	7	6	5	4	3	2	1	T	T	T	T	T	T	T	T	T	T	T	T	T	T	T	T	T	T	T	T	T	T	z	A	A	A	A	A	A	A	A	A	A	A	A	A	A	A	A	A	A	A	A	A	A	a	A	A	A	A	A	A	A	A	A	A	A	A	A	A	A	A	A	A	A	A	A	A	b	A	A	A	A	A	A	A	A	A	A	A	A	A	A	A	A	A	A	A	A	A	A	c	A	A	A	A	A	A	A	A	A	A	A	A	A	A	A	A	A	A	A	A	A	A	d	A	A	A	A	A	A	A	A	A	A	A	A	A	A	A	A	A	A	A	A	A	A	e	T	T	T	T	T	T	T	T	T	T	T	T	T	T	T	T	T	T	T	T	T	T	f	110	2	17 7200 110 200 012
22	21	20	19	18	17	16	15	14	13	12	11	10	9	8	7	6	5	4	3	2	1																																																																																																																																																																					
T	T	T	T	T	T	T	T	T	T	T	T	T	T	T	T	T	T	T	T	T	T	z																																																																																																																																																																				
A	A	A	A	A	A	A	A	A	A	A	A	A	A	A	A	A	A	A	A	A	A	a																																																																																																																																																																				
A	A	A	A	A	A	A	A	A	A	A	A	A	A	A	A	A	A	A	A	A	A	b																																																																																																																																																																				
A	A	A	A	A	A	A	A	A	A	A	A	A	A	A	A	A	A	A	A	A	A	c																																																																																																																																																																				
A	A	A	A	A	A	A	A	A	A	A	A	A	A	A	A	A	A	A	A	A	A	d																																																																																																																																																																				
A	A	A	A	A	A	A	A	A	A	A	A	A	A	A	A	A	A	A	A	A	A	e																																																																																																																																																																				
T	T	T	T	T	T	T	T	T	T	T	T	T	T	T	T	T	T	T	T	T	T	f																																																																																																																																																																				
<p>CompactPCI® Computer Telephony</p> <table border="1"> <tr><td>22</td><td>21</td><td>20</td><td>19</td><td>18</td><td>17</td><td>16</td><td>15</td><td>14</td><td>13</td><td>12</td><td>11</td><td>10</td><td>9</td><td>8</td><td>7</td><td>6</td><td>5</td><td>4</td><td>3</td><td>2</td><td>1</td></tr> <tr><td></td><td></td><td></td><td></td><td></td><td></td><td></td><td></td><td></td><td></td><td></td><td></td><td></td><td></td><td></td><td></td><td></td><td></td><td></td><td></td><td></td><td></td><td>z</td></tr> <tr><td>B</td><td>B</td><td>B</td><td>B</td><td>A</td><td>A</td><td>A</td><td>A</td><td>A</td><td>A</td><td>A</td><td>A</td><td>A</td><td>A</td><td>A</td><td>A</td><td>A</td><td>A</td><td>A</td><td>A</td><td>A</td><td>A</td><td>a</td></tr> <tr><td>B</td><td>B</td><td>B</td><td>B</td><td>A</td><td>A</td><td>A</td><td>A</td><td>A</td><td>A</td><td>A</td><td>A</td><td>A</td><td>A</td><td>A</td><td>A</td><td>A</td><td>A</td><td>A</td><td>A</td><td>A</td><td>A</td><td>b</td></tr> <tr><td>B</td><td>B</td><td>B</td><td>B</td><td>A</td><td>A</td><td>A</td><td>A</td><td>A</td><td>A</td><td>A</td><td>A</td><td>A</td><td>A</td><td>A</td><td>A</td><td>A</td><td>A</td><td>A</td><td>A</td><td>A</td><td>A</td><td>c</td></tr> <tr><td>B</td><td>B</td><td>B</td><td>B</td><td>A</td><td>A</td><td>A</td><td>A</td><td>A</td><td>A</td><td>A</td><td>A</td><td>A</td><td>A</td><td>A</td><td>A</td><td>A</td><td>A</td><td>A</td><td>A</td><td>A</td><td>A</td><td>d</td></tr> <tr><td>B</td><td>B</td><td>B</td><td>B</td><td>A</td><td>A</td><td>A</td><td>A</td><td>A</td><td>A</td><td>A</td><td>A</td><td>A</td><td>A</td><td>A</td><td>A</td><td>A</td><td>A</td><td>A</td><td>A</td><td>A</td><td>A</td><td>e</td></tr> <tr><td>C</td><td>C</td><td>C</td><td>C</td><td>C</td><td>C</td><td>C</td><td>C</td><td>C</td><td>C</td><td>C</td><td>C</td><td>C</td><td>C</td><td>C</td><td>C</td><td>C</td><td>C</td><td>C</td><td>C</td><td>C</td><td>C</td><td>f</td></tr> </table>	22	21	20	19	18	17	16	15	14	13	12	11	10	9	8	7	6	5	4	3	2	1																							z	B	B	B	B	A	A	A	A	A	A	A	A	A	A	A	A	A	A	A	A	A	A	a	B	B	B	B	A	A	A	A	A	A	A	A	A	A	A	A	A	A	A	A	A	A	b	B	B	B	B	A	A	A	A	A	A	A	A	A	A	A	A	A	A	A	A	A	A	c	B	B	B	B	A	A	A	A	A	A	A	A	A	A	A	A	A	A	A	A	A	A	d	B	B	B	B	A	A	A	A	A	A	A	A	A	A	A	A	A	A	A	A	A	A	e	C	C	C	C	C	C	C	C	C	C	C	C	C	C	C	C	C	C	C	C	C	C	f	132	2	17 7200 132 211 002
22	21	20	19	18	17	16	15	14	13	12	11	10	9	8	7	6	5	4	3	2	1																																																																																																																																																																					
																						z																																																																																																																																																																				
B	B	B	B	A	A	A	A	A	A	A	A	A	A	A	A	A	A	A	A	A	A	a																																																																																																																																																																				
B	B	B	B	A	A	A	A	A	A	A	A	A	A	A	A	A	A	A	A	A	A	b																																																																																																																																																																				
B	B	B	B	A	A	A	A	A	A	A	A	A	A	A	A	A	A	A	A	A	A	c																																																																																																																																																																				
B	B	B	B	A	A	A	A	A	A	A	A	A	A	A	A	A	A	A	A	A	A	d																																																																																																																																																																				
B	B	B	B	A	A	A	A	A	A	A	A	A	A	A	A	A	A	A	A	A	A	e																																																																																																																																																																				
C	C	C	C	C	C	C	C	C	C	C	C	C	C	C	C	C	C	C	C	C	C	f																																																																																																																																																																				

Technical description and dimensions see page 36

AVX will custom load connectors with any combination of the contacts in the table on page 39. Complete the form on page 57 and fax it to the number shown.

Vertical Male

Series 7200 – Style B 19, 133 Contacts

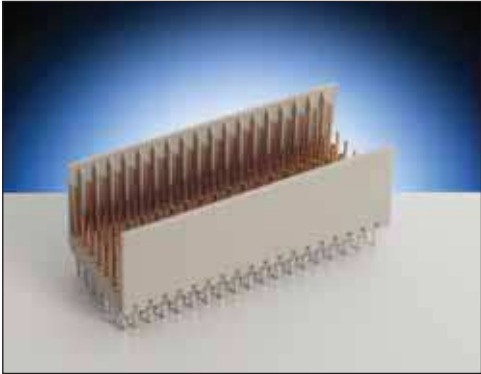

- Up to 95 signal contacts and 38 ground shield contacts in 5 or 5+2 rows of 19 positions
- Designed for gas tight press-fit installations
- This connector fills position P3 of the CompactPCI® specification and should be used with a type A or AB connector
- Twelve different contact styles are available for customizing connector to exact specifications (complete form on page 58)
- This connector also fills position J0 of the VME64 Extension Specification



DIMENSIONS: millimeters (inches)

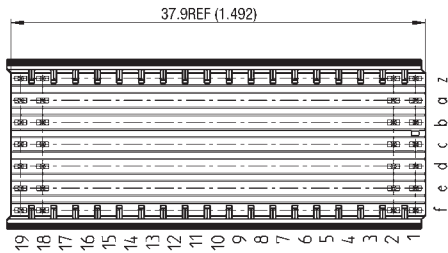
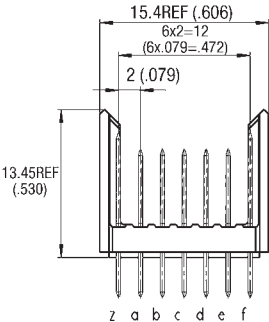
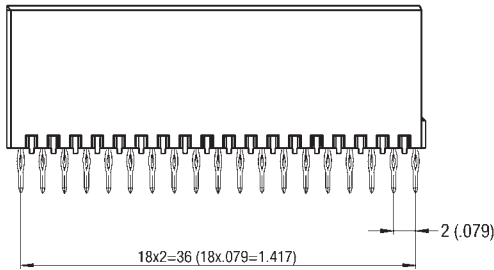

LAYOUT

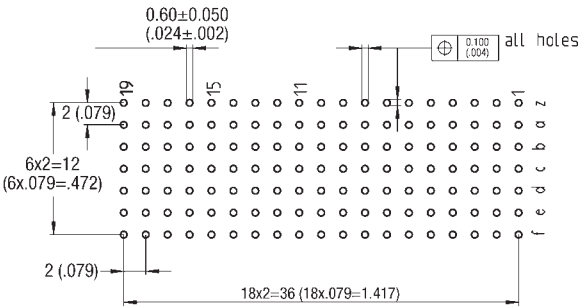

Vertical Male

Style B 19 – 133 Contacts



Pin Loading	Contacts	Performance Class	Part Number
<p>P3 CompactPCI®</p>	133	2	17 7200 133 300 002
<p>P3 CompactPCI®</p>	133	2	17 7200 133 301 002
<p>P3 CompactPCI®</p>	133	2	17 7200 133 302 005
<p>P3 CompactPCI®</p>	133	2	17 7200 133 303 005
<p>P3 CompactPCI®</p>	133	2	17 7200 133 304 005
	95	2	17 7200 095 300 012

Technical description and dimensions see page 38

AVX will custom load connectors with any combination of the contacts in the table below. Complete the form on page 57 and fax it to the number shown.

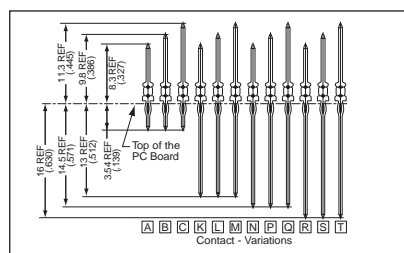

Vertical Male

Series 7200 – Style C 11, 77 Contacts

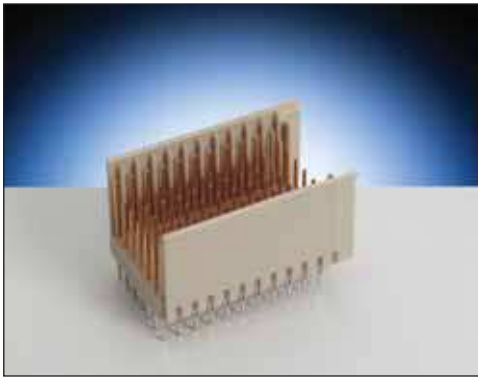

- Up to 55 signal contacts and 22 ground shield contacts in 5 or 5+2 rows of 11 positions
- This connector is designed for end positions only
- Designed for gas tight press-fit installations
- Twelve different contact styles are available for customizing connector to exact specifications (complete form on page 57)
- This connector should be used in conjunction with a Style A or AB connector



DIMENSIONS: millimeters (inches)

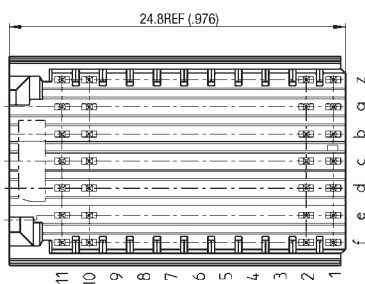
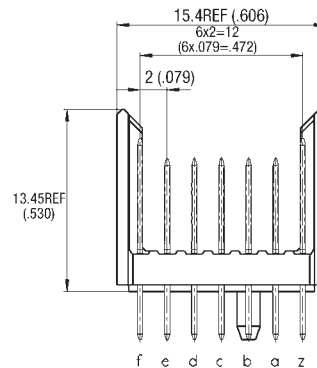
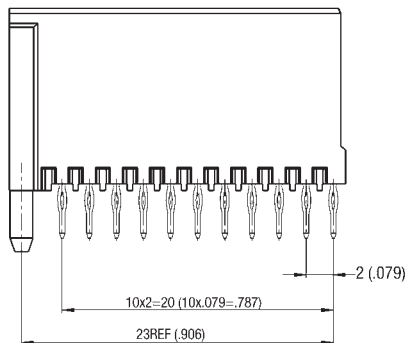

LAYOUT

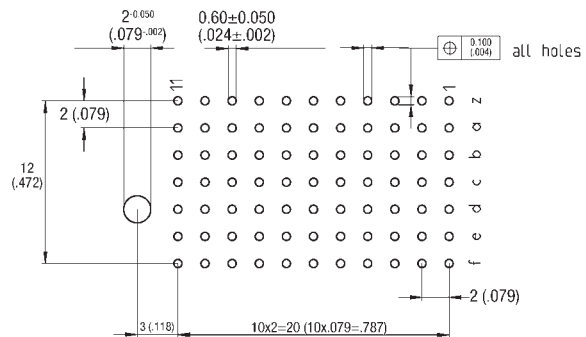

Vertical Male

Style C 11 – 77 Contacts



Pin Loading	Contacts	Performance Class	Part Number																																																																																																
<table border="1"> <tr><td>11</td><td>10</td><td>9</td><td>8</td><td>7</td><td>6</td><td>5</td><td>4</td><td>3</td><td>2</td><td>1</td><td></td></tr> <tr><td>C</td><td>C</td><td>C</td><td>C</td><td>C</td><td>C</td><td>C</td><td>C</td><td>C</td><td>C</td><td>C</td><td>z</td></tr> <tr><td>A</td><td>A</td><td>A</td><td>A</td><td>A</td><td>A</td><td>A</td><td>A</td><td>A</td><td>A</td><td>A</td><td>a</td></tr> <tr><td>A</td><td>A</td><td>A</td><td>A</td><td>A</td><td>A</td><td>A</td><td>A</td><td>A</td><td>A</td><td>A</td><td>b</td></tr> <tr><td>A</td><td>A</td><td>A</td><td>A</td><td>A</td><td>A</td><td>A</td><td>A</td><td>A</td><td>A</td><td>A</td><td>c</td></tr> <tr><td>A</td><td>A</td><td>A</td><td>A</td><td>A</td><td>A</td><td>A</td><td>A</td><td>A</td><td>A</td><td>A</td><td>d</td></tr> <tr><td>A</td><td>A</td><td>A</td><td>A</td><td>A</td><td>A</td><td>A</td><td>A</td><td>A</td><td>A</td><td>A</td><td>e</td></tr> <tr><td>C</td><td>C</td><td>C</td><td>C</td><td>C</td><td>C</td><td>C</td><td>C</td><td>C</td><td>C</td><td>C</td><td>f</td></tr> </table>	11	10	9	8	7	6	5	4	3	2	1		C	C	C	C	C	C	C	C	C	C	C	z	A	A	A	A	A	A	A	A	A	A	A	a	A	A	A	A	A	A	A	A	A	A	A	b	A	A	A	A	A	A	A	A	A	A	A	c	A	A	A	A	A	A	A	A	A	A	A	d	A	A	A	A	A	A	A	A	A	A	A	e	C	C	C	C	C	C	C	C	C	C	C	f	77	2	17 7200 077 400 002
11	10	9	8	7	6	5	4	3	2	1																																																																																									
C	C	C	C	C	C	C	C	C	C	C	z																																																																																								
A	A	A	A	A	A	A	A	A	A	A	a																																																																																								
A	A	A	A	A	A	A	A	A	A	A	b																																																																																								
A	A	A	A	A	A	A	A	A	A	A	c																																																																																								
A	A	A	A	A	A	A	A	A	A	A	d																																																																																								
A	A	A	A	A	A	A	A	A	A	A	e																																																																																								
C	C	C	C	C	C	C	C	C	C	C	f																																																																																								
<table border="1"> <tr><td>11</td><td>10</td><td>9</td><td>8</td><td>7</td><td>6</td><td>5</td><td>4</td><td>3</td><td>2</td><td>1</td><td></td></tr> <tr><td>C</td><td>C</td><td>C</td><td>C</td><td>C</td><td>C</td><td>C</td><td>C</td><td>C</td><td>C</td><td>C</td><td>z</td></tr> <tr><td>B</td><td>B</td><td>B</td><td>B</td><td>B</td><td>B</td><td>B</td><td>B</td><td>B</td><td>B</td><td>B</td><td>a</td></tr> <tr><td>B</td><td>B</td><td>B</td><td>B</td><td>B</td><td>B</td><td>B</td><td>B</td><td>B</td><td>B</td><td>B</td><td>b</td></tr> <tr><td>B</td><td>B</td><td>B</td><td>B</td><td>B</td><td>B</td><td>B</td><td>B</td><td>B</td><td>B</td><td>B</td><td>c</td></tr> <tr><td>B</td><td>B</td><td>B</td><td>B</td><td>B</td><td>B</td><td>B</td><td>B</td><td>B</td><td>B</td><td>B</td><td>d</td></tr> <tr><td>B</td><td>B</td><td>B</td><td>B</td><td>B</td><td>B</td><td>B</td><td>B</td><td>B</td><td>B</td><td>B</td><td>e</td></tr> <tr><td>C</td><td>C</td><td>C</td><td>C</td><td>C</td><td>C</td><td>C</td><td>C</td><td>C</td><td>C</td><td>C</td><td>f</td></tr> </table>	11	10	9	8	7	6	5	4	3	2	1		C	C	C	C	C	C	C	C	C	C	C	z	B	B	B	B	B	B	B	B	B	B	B	a	B	B	B	B	B	B	B	B	B	B	B	b	B	B	B	B	B	B	B	B	B	B	B	c	B	B	B	B	B	B	B	B	B	B	B	d	B	B	B	B	B	B	B	B	B	B	B	e	C	C	C	C	C	C	C	C	C	C	C	f	77	2	17 7200 077 401 002
11	10	9	8	7	6	5	4	3	2	1																																																																																									
C	C	C	C	C	C	C	C	C	C	C	z																																																																																								
B	B	B	B	B	B	B	B	B	B	B	a																																																																																								
B	B	B	B	B	B	B	B	B	B	B	b																																																																																								
B	B	B	B	B	B	B	B	B	B	B	c																																																																																								
B	B	B	B	B	B	B	B	B	B	B	d																																																																																								
B	B	B	B	B	B	B	B	B	B	B	e																																																																																								
C	C	C	C	C	C	C	C	C	C	C	f																																																																																								
<table border="1"> <tr><td>11</td><td>10</td><td>9</td><td>8</td><td>7</td><td>6</td><td>5</td><td>4</td><td>3</td><td>2</td><td>1</td><td></td></tr> <tr><td>T</td><td>T</td><td>T</td><td>T</td><td>T</td><td>T</td><td>T</td><td>T</td><td>T</td><td>T</td><td>T</td><td>z</td></tr> <tr><td>P</td><td>P</td><td>P</td><td>P</td><td>P</td><td>P</td><td>P</td><td>P</td><td>P</td><td>P</td><td>P</td><td>a</td></tr> <tr><td>P</td><td>P</td><td>P</td><td>P</td><td>P</td><td>P</td><td>P</td><td>P</td><td>P</td><td>P</td><td>P</td><td>b</td></tr> <tr><td>P</td><td>P</td><td>P</td><td>P</td><td>P</td><td>P</td><td>P</td><td>P</td><td>P</td><td>P</td><td>P</td><td>c</td></tr> <tr><td>P</td><td>P</td><td>P</td><td>P</td><td>P</td><td>P</td><td>P</td><td>P</td><td>P</td><td>P</td><td>P</td><td>d</td></tr> <tr><td>P</td><td>P</td><td>P</td><td>P</td><td>P</td><td>P</td><td>P</td><td>P</td><td>P</td><td>P</td><td>P</td><td>e</td></tr> <tr><td>T</td><td>T</td><td>T</td><td>T</td><td>T</td><td>T</td><td>T</td><td>T</td><td>T</td><td>T</td><td>T</td><td>f</td></tr> </table>	11	10	9	8	7	6	5	4	3	2	1		T	T	T	T	T	T	T	T	T	T	T	z	P	P	P	P	P	P	P	P	P	P	P	a	P	P	P	P	P	P	P	P	P	P	P	b	P	P	P	P	P	P	P	P	P	P	P	c	P	P	P	P	P	P	P	P	P	P	P	d	P	P	P	P	P	P	P	P	P	P	P	e	T	T	T	T	T	T	T	T	T	T	T	f	77	2	17 7200 077 402 005
11	10	9	8	7	6	5	4	3	2	1																																																																																									
T	T	T	T	T	T	T	T	T	T	T	z																																																																																								
P	P	P	P	P	P	P	P	P	P	P	a																																																																																								
P	P	P	P	P	P	P	P	P	P	P	b																																																																																								
P	P	P	P	P	P	P	P	P	P	P	c																																																																																								
P	P	P	P	P	P	P	P	P	P	P	d																																																																																								
P	P	P	P	P	P	P	P	P	P	P	e																																																																																								
T	T	T	T	T	T	T	T	T	T	T	f																																																																																								
<table border="1"> <tr><td>11</td><td>10</td><td>9</td><td>8</td><td>7</td><td>6</td><td>5</td><td>4</td><td>3</td><td>2</td><td>1</td><td></td></tr> <tr><td>T</td><td>T</td><td>T</td><td>T</td><td>T</td><td>T</td><td>T</td><td>T</td><td>T</td><td>T</td><td>T</td><td>z</td></tr> <tr><td>R</td><td>R</td><td>R</td><td>R</td><td>R</td><td>R</td><td>R</td><td>R</td><td>R</td><td>R</td><td>R</td><td>a</td></tr> <tr><td>R</td><td>R</td><td>R</td><td>R</td><td>R</td><td>R</td><td>R</td><td>R</td><td>R</td><td>R</td><td>R</td><td>b</td></tr> <tr><td>R</td><td>R</td><td>R</td><td>R</td><td>R</td><td>R</td><td>R</td><td>R</td><td>R</td><td>R</td><td>R</td><td>c</td></tr> <tr><td>R</td><td>R</td><td>R</td><td>R</td><td>R</td><td>R</td><td>R</td><td>R</td><td>R</td><td>R</td><td>R</td><td>d</td></tr> <tr><td>R</td><td>R</td><td>R</td><td>R</td><td>R</td><td>R</td><td>R</td><td>R</td><td>R</td><td>R</td><td>R</td><td>e</td></tr> <tr><td>T</td><td>T</td><td>T</td><td>T</td><td>T</td><td>T</td><td>T</td><td>T</td><td>T</td><td>T</td><td>T</td><td>f</td></tr> </table>	11	10	9	8	7	6	5	4	3	2	1		T	T	T	T	T	T	T	T	T	T	T	z	R	R	R	R	R	R	R	R	R	R	R	a	R	R	R	R	R	R	R	R	R	R	R	b	R	R	R	R	R	R	R	R	R	R	R	c	R	R	R	R	R	R	R	R	R	R	R	d	R	R	R	R	R	R	R	R	R	R	R	e	T	T	T	T	T	T	T	T	T	T	T	f	77	2	17 7200 077 403 005
11	10	9	8	7	6	5	4	3	2	1																																																																																									
T	T	T	T	T	T	T	T	T	T	T	z																																																																																								
R	R	R	R	R	R	R	R	R	R	R	a																																																																																								
R	R	R	R	R	R	R	R	R	R	R	b																																																																																								
R	R	R	R	R	R	R	R	R	R	R	c																																																																																								
R	R	R	R	R	R	R	R	R	R	R	d																																																																																								
R	R	R	R	R	R	R	R	R	R	R	e																																																																																								
T	T	T	T	T	T	T	T	T	T	T	f																																																																																								
<table border="1"> <tr><td>11</td><td>10</td><td>9</td><td>8</td><td>7</td><td>6</td><td>5</td><td>4</td><td>3</td><td>2</td><td>1</td><td></td></tr> <tr><td>T</td><td>T</td><td>T</td><td>T</td><td>T</td><td>T</td><td>T</td><td>T</td><td>T</td><td>T</td><td>T</td><td>z</td></tr> <tr><td>K</td><td>K</td><td>K</td><td>K</td><td>K</td><td>K</td><td>K</td><td>K</td><td>K</td><td>K</td><td>K</td><td>a</td></tr> <tr><td>K</td><td>K</td><td>K</td><td>K</td><td>K</td><td>K</td><td>K</td><td>K</td><td>K</td><td>K</td><td>K</td><td>b</td></tr> <tr><td>K</td><td>K</td><td>K</td><td>K</td><td>K</td><td>K</td><td>K</td><td>K</td><td>K</td><td>K</td><td>K</td><td>c</td></tr> <tr><td>K</td><td>K</td><td>K</td><td>K</td><td>K</td><td>K</td><td>K</td><td>K</td><td>K</td><td>K</td><td>K</td><td>d</td></tr> <tr><td>K</td><td>K</td><td>K</td><td>K</td><td>K</td><td>K</td><td>K</td><td>K</td><td>K</td><td>K</td><td>K</td><td>e</td></tr> <tr><td>T</td><td>T</td><td>T</td><td>T</td><td>T</td><td>T</td><td>T</td><td>T</td><td>T</td><td>T</td><td>T</td><td>f</td></tr> </table>	11	10	9	8	7	6	5	4	3	2	1		T	T	T	T	T	T	T	T	T	T	T	z	K	K	K	K	K	K	K	K	K	K	K	a	K	K	K	K	K	K	K	K	K	K	K	b	K	K	K	K	K	K	K	K	K	K	K	c	K	K	K	K	K	K	K	K	K	K	K	d	K	K	K	K	K	K	K	K	K	K	K	e	T	T	T	T	T	T	T	T	T	T	T	f	77	2	17 7200 077 404 005
11	10	9	8	7	6	5	4	3	2	1																																																																																									
T	T	T	T	T	T	T	T	T	T	T	z																																																																																								
K	K	K	K	K	K	K	K	K	K	K	a																																																																																								
K	K	K	K	K	K	K	K	K	K	K	b																																																																																								
K	K	K	K	K	K	K	K	K	K	K	c																																																																																								
K	K	K	K	K	K	K	K	K	K	K	d																																																																																								
K	K	K	K	K	K	K	K	K	K	K	e																																																																																								
T	T	T	T	T	T	T	T	T	T	T	f																																																																																								
<table border="1"> <tr><td>11</td><td>10</td><td>9</td><td>8</td><td>7</td><td>6</td><td>5</td><td>4</td><td>3</td><td>2</td><td>1</td><td></td></tr> <tr><td></td><td></td><td></td><td></td><td></td><td></td><td></td><td></td><td></td><td></td><td></td><td>z</td></tr> <tr><td>B</td><td>B</td><td>B</td><td>B</td><td>B</td><td>B</td><td>B</td><td>B</td><td>B</td><td>B</td><td>B</td><td>a</td></tr> <tr><td>B</td><td>B</td><td>B</td><td>B</td><td>B</td><td>B</td><td>B</td><td>B</td><td>B</td><td>B</td><td>B</td><td>b</td></tr> <tr><td>B</td><td>B</td><td>B</td><td>B</td><td>B</td><td>B</td><td>B</td><td>B</td><td>B</td><td>B</td><td>B</td><td>c</td></tr> <tr><td>B</td><td>B</td><td>B</td><td>B</td><td>B</td><td>B</td><td>B</td><td>B</td><td>B</td><td>B</td><td>B</td><td>d</td></tr> <tr><td>B</td><td>B</td><td>B</td><td>B</td><td>B</td><td>B</td><td>B</td><td>B</td><td>B</td><td>B</td><td>B</td><td>e</td></tr> <tr><td></td><td></td><td></td><td></td><td></td><td></td><td></td><td></td><td></td><td></td><td></td><td>f</td></tr> </table>	11	10	9	8	7	6	5	4	3	2	1													z	B	B	B	B	B	B	B	B	B	B	B	a	B	B	B	B	B	B	B	B	B	B	B	b	B	B	B	B	B	B	B	B	B	B	B	c	B	B	B	B	B	B	B	B	B	B	B	d	B	B	B	B	B	B	B	B	B	B	B	e												f	55	2	17 7200 055 401 012
11	10	9	8	7	6	5	4	3	2	1																																																																																									
											z																																																																																								
B	B	B	B	B	B	B	B	B	B	B	a																																																																																								
B	B	B	B	B	B	B	B	B	B	B	b																																																																																								
B	B	B	B	B	B	B	B	B	B	B	c																																																																																								
B	B	B	B	B	B	B	B	B	B	B	d																																																																																								
B	B	B	B	B	B	B	B	B	B	B	e																																																																																								
											f																																																																																								

Technical description and dimensions see page 40

AVX will custom load connectors with any combination of the contacts in the table below. Complete the form on page 57 and fax it to the number shown.

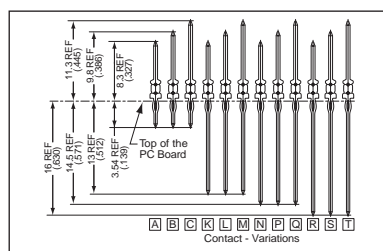

Type D Vertical Male for Backplanes



Series 8077

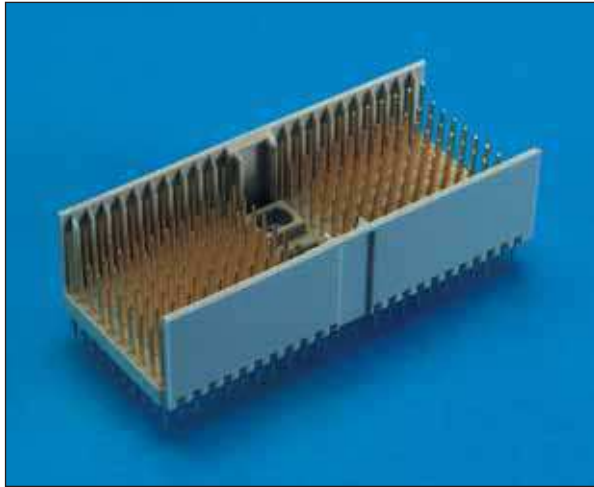

- 176 signal contacts plus 44 ground shield contacts in 8+2 x 25 position configuration
- Center cavity with keying option (uses 3 positions)
- Prealignment guides
- Designed for gas tight press-fit installation
- See pages 52 and 53 for keying options
- This connector can be used by itself or in conjunction with Style E or F connectors
- Twelve different contact styles available for customizing connector to exact specifications (see page 58)



17 8077 220 501 XXX+ = 176 signal contacts and 44 ground contacts, Short Tail, L2,3
17 8077 176 503 XXX+ = 176 signal contacts, no ground contacts, Short Tail, L2

XXX =

Plating Code	Contact Area	Press-fit Area	Under Coat
833	0.1µm min. Au.65µm Pd/Ni	1.5-3.0µm Sn	1.2-3.0µm Ni
863	0.76µm min. Au	1.5-3.0µm Sn	1.2-3.0µm Ni

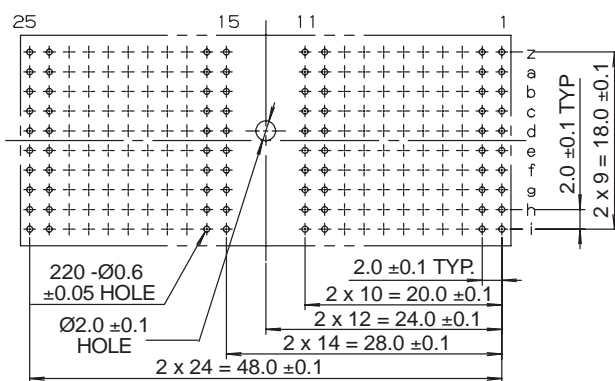
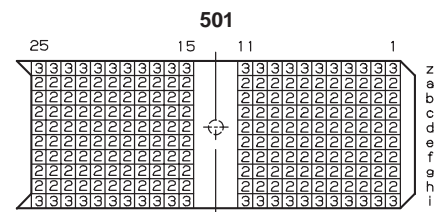
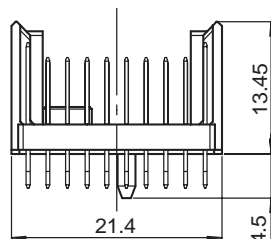
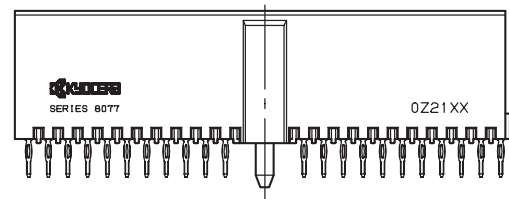
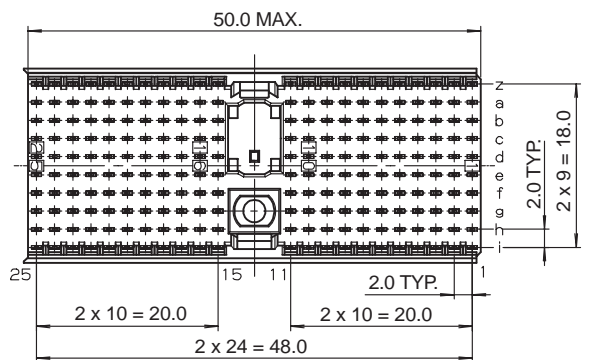

RECOMMENDED P.C. BOARD LAYOUT
(COMPONENT SIDE)

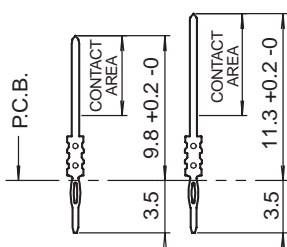

CONTACT DETAIL

Type E Vertical Male for Backplanes

Series 8077

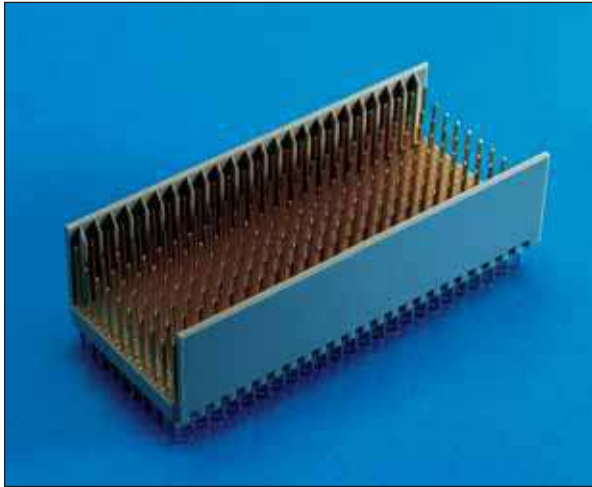

- 250 signal contacts and 50 ground shield contacts in 8+2 x 25 position configuration
- Designed for gas tight press-fit installation
- This connector should be used in conjunction with a Type D style to ensure proper mating alignment
- Twelve different contact styles are available for customizing connector to exact specifications (see page 58)



17 8077 250 502 XXX+ = 250 signal contacts and 50 ground contacts, Short Tail, L2,3
17 8077 200 504 XXX+ = 250 signal contacts, no ground contacts, Short Tail, L2

XXX =

Plating Code	Contact Area	Press-fit Area	Under Coat
833	0.1µm min. Au.65µm Pd/Ni	1.5-3.0µm Sn	1.2-3.0µm Ni
863	0.76µm min. Au	1.5-3.0µm Sn	1.2-3.0µm Ni

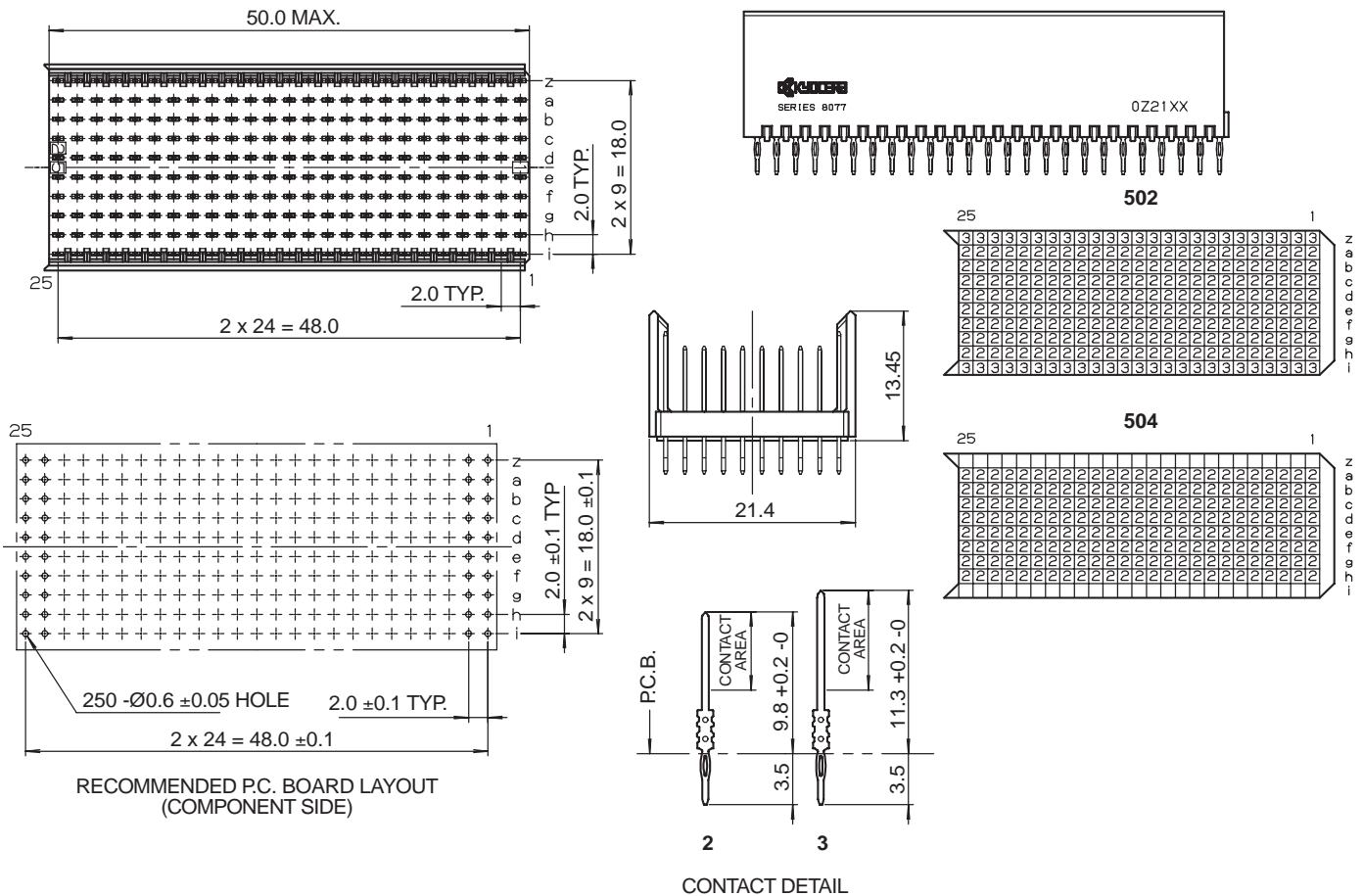

Type L Vertical Male for Backplanes



Series 8074



- 6 power or coax contact cavities
- Center cavity with prealignment guides and keying option
- See pages 52 and 53 for keying options
- Supplied with locating pegs for secure P.C. board mounting
- This connector can be used by itself or in conjunction with B, C, or M connectors
- Power and coax contacts are ordered separately
- See pages 54 and 55 for available contacts



61 8074 006 001 007+ = Type L 6 position power connector with polarizing key, (housing only)

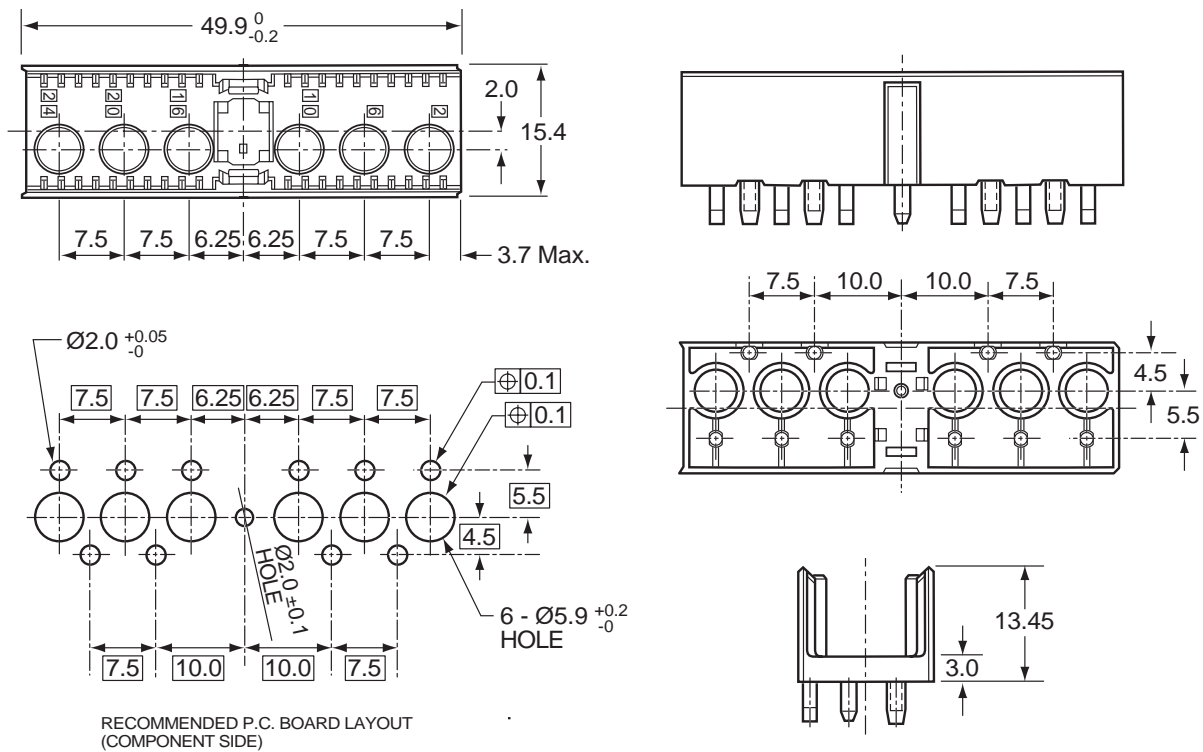

Type M Vertical Male Feed-To for Backplanes



Series 8075

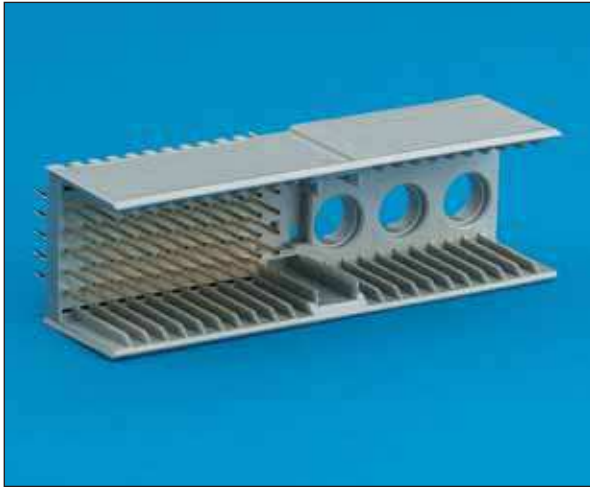

- 3 power contact cavities
- 55 signal contacts
- Center cavity with prealignment guides and keying option
- See pages 52 and 53 for keying options
- Designed for gas tight press-fit installation
- Supplied with locating pegs for secure P.C. board mounting
- Power and coax contacts are ordered separately
- See pages 54 and 55 for available contacts
- Twelve different signal contact styles are available for customizing connector to exact specifications (see page 58)



17 8075 355 501 863+ = Type M 3 position power connector with polarizing key, with 55 signal contacts, L1

Plating Code	Contact Area	Press-fit Area	Under Coat
863	0.76µm min. Au	1.5-3.0µm Sn	1.2-3.0µm Ni

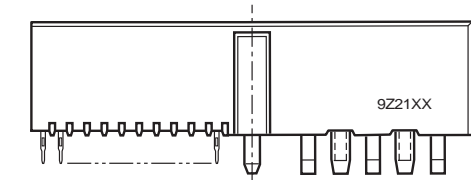
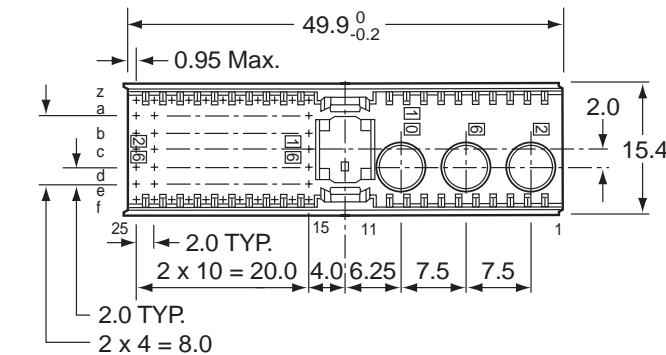

CONTACT LAYOUT (CONNECTOR MATING SIDE SHOWN)

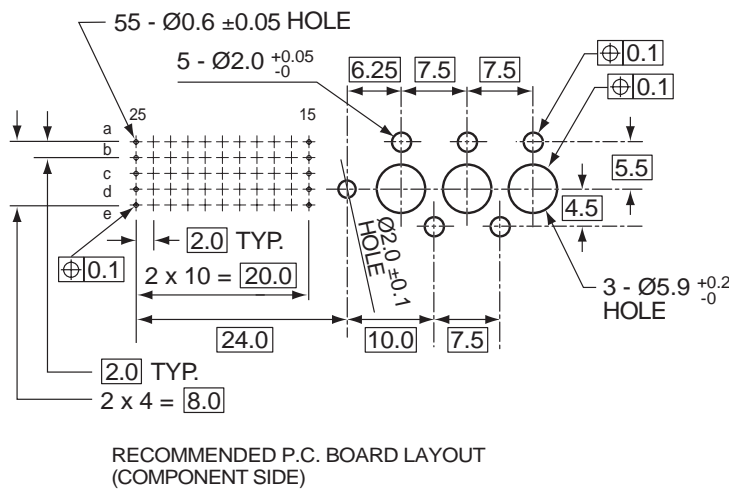
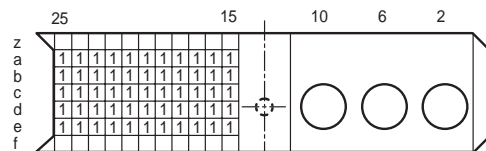

RECOMMENDED P.C. BOARD LAYOUT (COMPONENT SIDE)

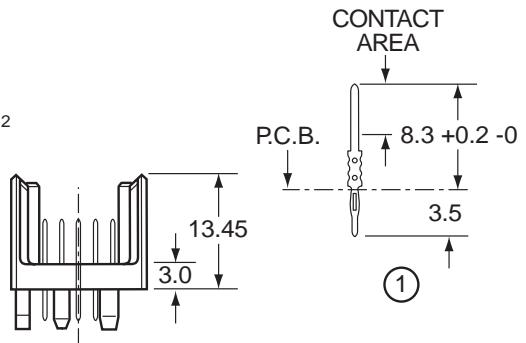

Type A Right Angle Male for Daughter Cards

Series 8072



- 110 signal contacts
- Designed for gas tight press-fit installation
- Center cavity with prealignment guides and keying option (uses 3 positions)
- This connector can be used by itself or in conjunction with Style B or C connectors
- See pages 52 and 53 for keying options
- Daughter card applications



17 8072 110 001 863+ = Type A Right Angle Male

Plating Code	Contact Area	Press-fit Area	Under Coat
863	0.76µm min. Au	1.5-3.0µm Sn	1.2-3.0µm Ni

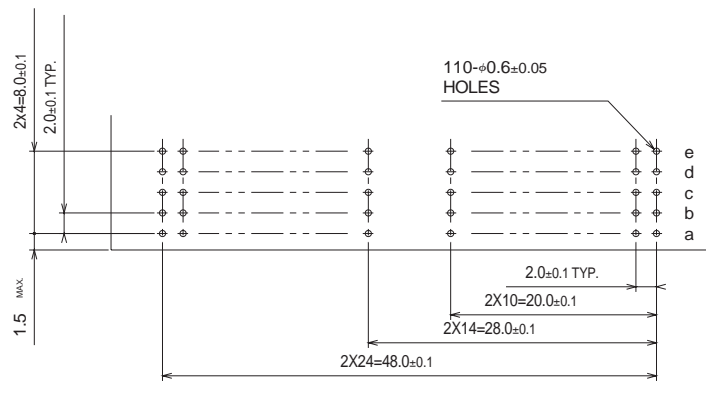
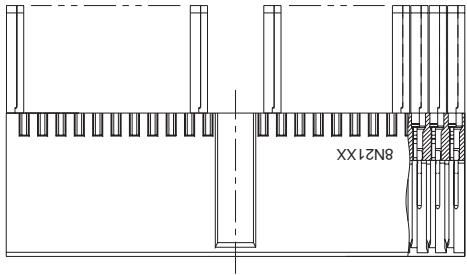
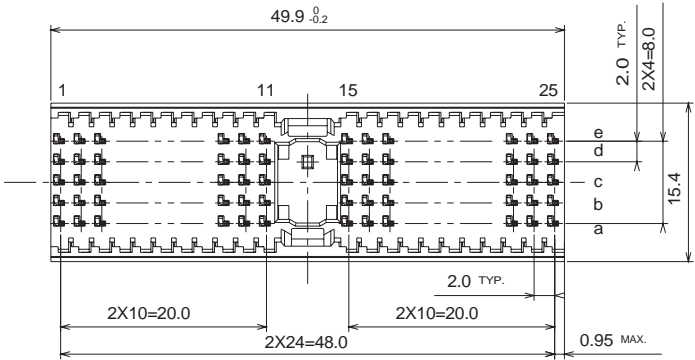

RECOMMENDED P.C. BOARD LAYOUT
(COMPONENT SIDE)

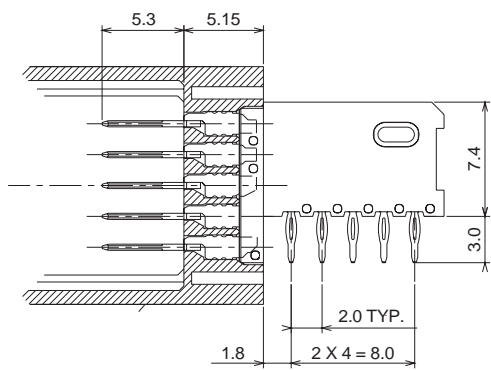

Type B Right Angle Male for Daughter Cards

Series 8072



- 95, 110, 125 signal contacts
- Designed for gas tight press-fit installation
- This connector should be used in conjunction with a Type A style to ensure proper alignment
- Daughter card applications



17 8072 095 000 863+ = Type B 19 Right Angle Male, 5x19 Positions
17 8072 110 000 863+ = Type B 22 Right Angle Male, 5x22 Positions
17 8072 125 000 863+ = Type B 25 Right Angle Male, 5x25 Positions

Plating Code	Contact Area	Press-fit Area	Under Coat
863	0.76µm min. Au	1.5-3.0µm Sn	1.2-3.0µm Ni

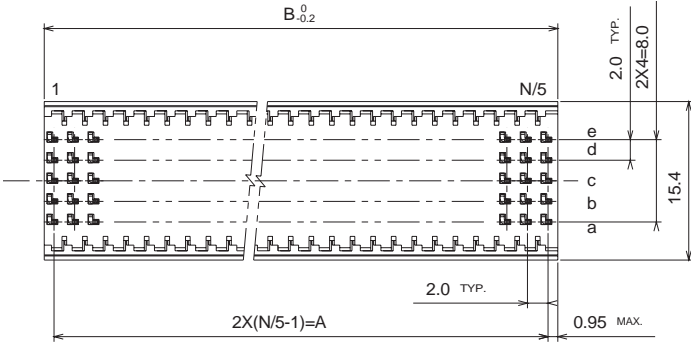

P/N	A	B
17 8072 095 000 863	36.0	37.9
17 8072 110 000 863	42.0	43.9
17 8072 125 000 863	48.0	49.9

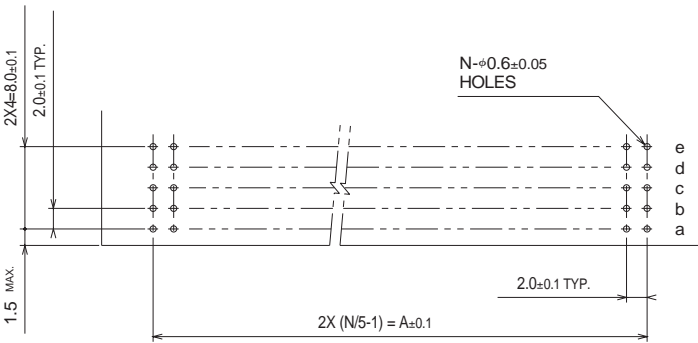

RECOMMENDED P.C. BOARD LAYOUT
(COMPONENT SIDE)

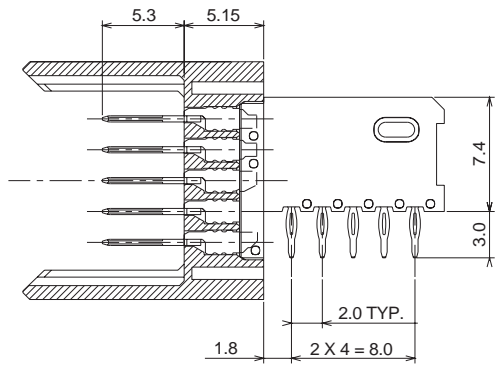

Type C Right Angle Male for Daughter Cards

Series 8072



- 55 signal contacts in a 5 x 11 position configuration
- Prealignment guide
- Designed for gas tight press-fit installation
- This connector should be used in conjunction with Style A & B connectors
- Used for end position only



17 8072 055 001 863+ = 55 signal contacts

Plating Code	Contact Area	Press-fit Area	Under Coat
863	0.76µm min. Au	1.5-3.0µm Sn	1.2-3.0µm Ni

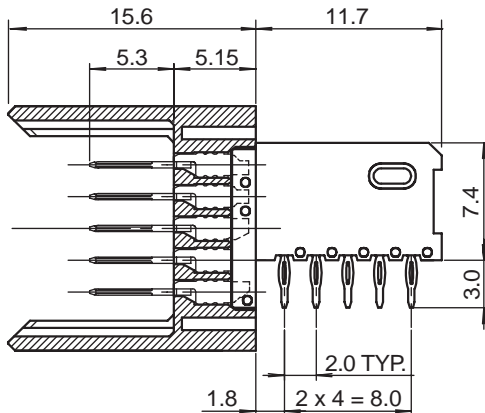
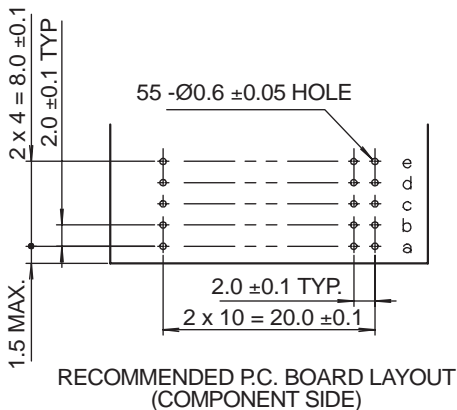
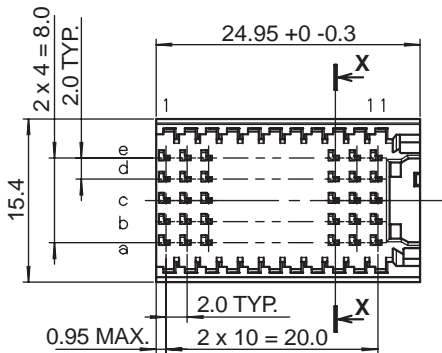
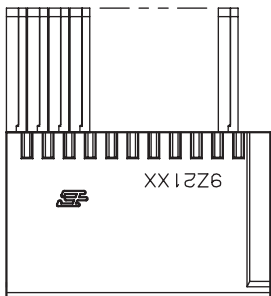

Press-fit Tools

Series 7200



AVX 2mm Hard Metric right angle female connectors are designed to be assembled to the board without the need for a special press-fit tool. These connectors can be installed using the “flat rock” method. The AVX modular tool system for 2mm Hard Metric vertical headers can be grouped to

allow for multiple press-fit operations. This makes it possible to install several connectors in a row, with one press operation. The grooves on the sides of the tools allow for easy installation into an assembly press.

PART NUMBER SYSTEM (VERTICAL MALE CONNECTORS)

Part Number	Size	Pins	“n”	Dim. “Y”	Dim. “X”
06 7200 0201 00 000	B25	175	25	48.00	50.00
06 7200 0202 00 000	A	154	22	48.00	50.00
06 7200 0203 00 000	B22	154	22	42.00	44.00
06 7200 0204 00 000	B19	133	19	36.00	38.00
06 7200 0205 00 000	C11	77	11	20.00	22.00

06 7200 0203 00 000
Type B22 (7 x 22)
154 Pins

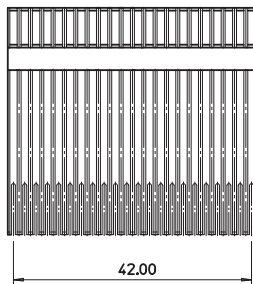

06 7200 0204 00 000
Type B19 (7 x 19)
133 Pins

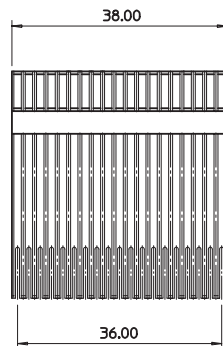

06 7200 0205 00 000
Type C (7 x 11)
77 Pins

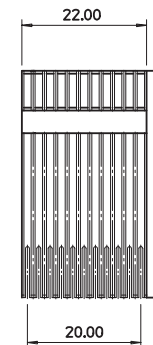

06 7200 0202 00 000
Type A (7 x 22)
154 Pins with Coding

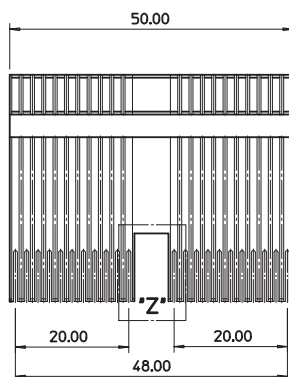

06 7200 0201 00 000
Type B25 (7 x 25)
175 Pins

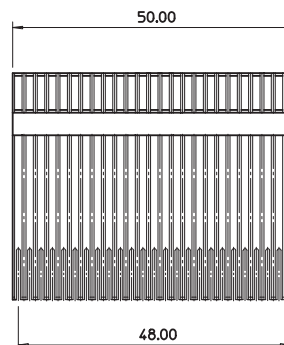

Shroud

Type B for Midplane and Rear I/O Assemblies Series 7200

- Use in conjunction with feedthru connectors
- When installed over the long tails, a male connector is created
- Enables rear Input/Output or midplane applications with daughter cards or cable assemblies
- No spacer required
- 3 heights available to accommodate different board thicknesses
- Other versions available upon request

67 7200 6124 00 000 = B 175 cavities (25 position) L=3.9mm; H=14.35mm; PCB Thickness 4.0mm

67 7200 6164 00 000 = B 175 cavities (25 position) L=4.7mm; H=15.15mm; PCB Thickness 3.2mm

67 7200 6184 00 000 = B 175 cavities (25 position) L=5.3mm; H=15.75mm; PCB Thickness 2.4mm

67 7200 6194 00 000 = B 175 cavities (25 position) L=6.1mm; H=16.55mm; PCB Thickness 1.6mm

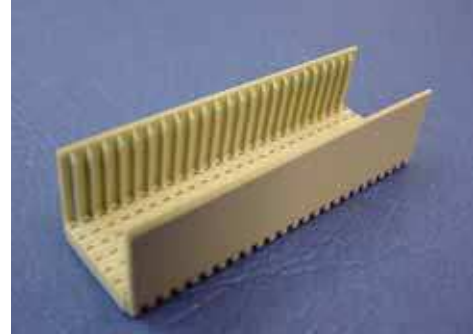

67 7200 6224 00 000 = B 154 cavities (22 position) L=3.9mm; H=14.35mm; PCB Thickness 4.0mm

67 7200 6264 00 000 = B 154 cavities (22 position) L=4.7mm; H=15.15mm; PCB Thickness 3.2mm

67 7200 6284 00 000 = B 154 cavities (22 position) L=5.3mm; H=15.75mm; PCB Thickness 2.4mm

67 7200 6294 00 000 = B 154 cavities (22 position) L=6.1mm; H=16.55mm; PCB Thickness 1.6mm

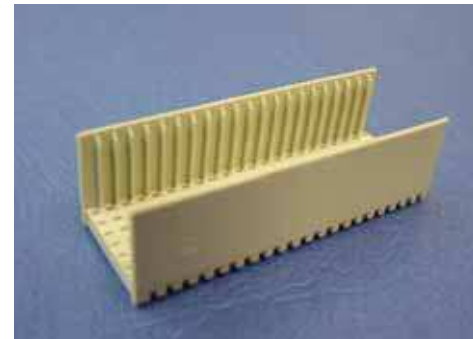

67 7200 6324 00 000 = B 133 cavities (19 position) L=3.9mm; H=14.35mm; PCB Thickness 4.0mm

67 7200 6364 00 000 = B 133 cavities (19 position) L=4.7mm; H=15.15mm; PCB Thickness 3.2mm

67 7200 6384 00 000 = B 133 cavities (19 position) L=5.3mm; H=15.75mm; PCB Thickness 2.4mm

67 7200 6394 00 000 = B 133 cavities (19 position) L=6.1mm; H=16.55mm; PCB Thickness 1.6mm

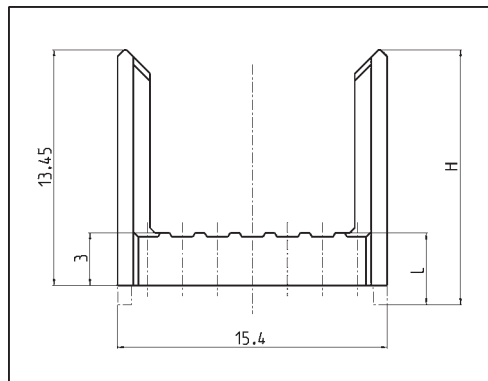
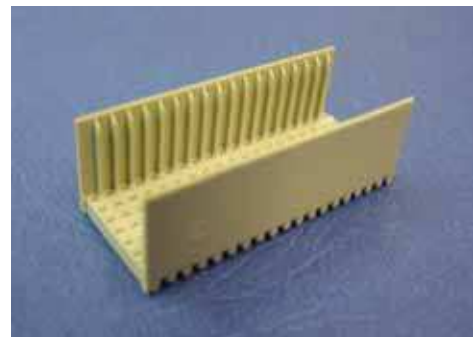

Shroud

Type A and C for Midplane and Rear I/O Assemblies Series 7200



- Used in conjunction with feedthru connectors
- When installed over the long tails, a male connector is created
- Used in conjunction with feedthru connectors
- When installed over the long tails, a male connector is created
- Enables rear Input/Output or midplane applications with daughter cards or cable assemblies
- No spacer required
- 3 heights available to accommodate different board thicknesses
- Other versions available upon request

67 7200 6024 00 000 = P1, P4 Type A 154 cavities (22 position)
L=3.9mm; H=14.35mm; PCB Thickness 4.0mm

67 7200 6064 00 000 = P1, P4 Type A 154 cavities (22 position)
L=4.7mm; H=15.15mm; PCB Thickness 3.2mm

67 7200 6084 00 000 = P1, P4 Type A 154 cavities (22 position)
L=5.3mm; H=15.75mm; PCB Thickness 2.4mm

67 7200 6094 00 000 = P1, P4 Type A 154 cavities (22 position)
L=6.1mm; H=16.55mm; PCB Thickness 1.6mm

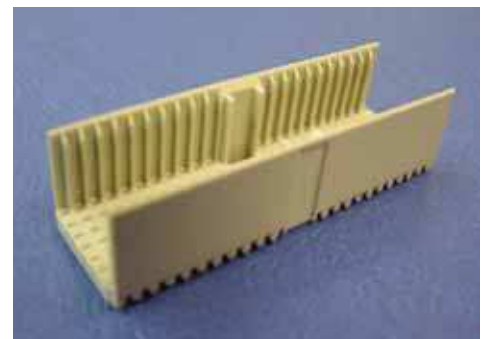

67 7200 6424 00 000 = Type C 77 cavities (11 position) L=3.9mm;
H=14.35mm; PCB Thickness 4.0mm

67 7200 6464 00 000 = Type C 77 cavities (11 position)
L=4.7mm; H=15.15mm; PCB Thickness 3.2mm

67 7200 6484 00 000 = Type C 77 cavities (11 position)
L=5.3mm; H=15.75mm; PCB Thickness 2.4mm

67 7200 6494 00 000 = Type C 77 cavities (11 position)
L=6.1mm; H=16.55mm; PCB Thickness 1.6mm

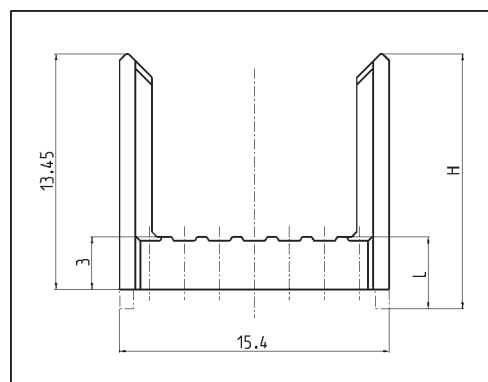
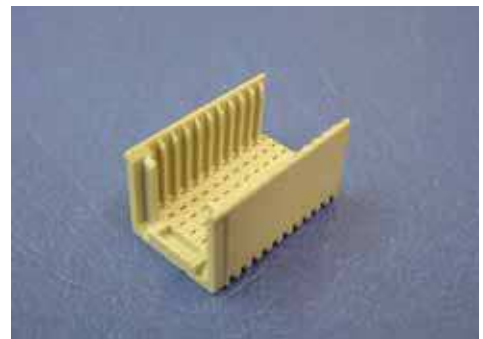

Coding Keys

Type A Male (Backplane) Type A Female (Daughter Card)

CompactPCI® supports two types of voltages (3.3V and 5.0V). Coding keys are used to prevent damage by inserting the wrong boards into a system. Keys are snapped into the center polarization cavity. 3.3V cards are coded cadmium yellow and 5.0V are brilliant blue.

In total there are 70 different codings available which can be used in conjunction with the CompactPCI® specification or upon customer's requirement.



MALE

Cadmium	Brilliant	Pastel	Strawberry
Yellow	Blue	Orange	Red

FEMALE

Cadmium	Brilliant	Pastel	Strawberry
Yellow	Blue	Orange	Red

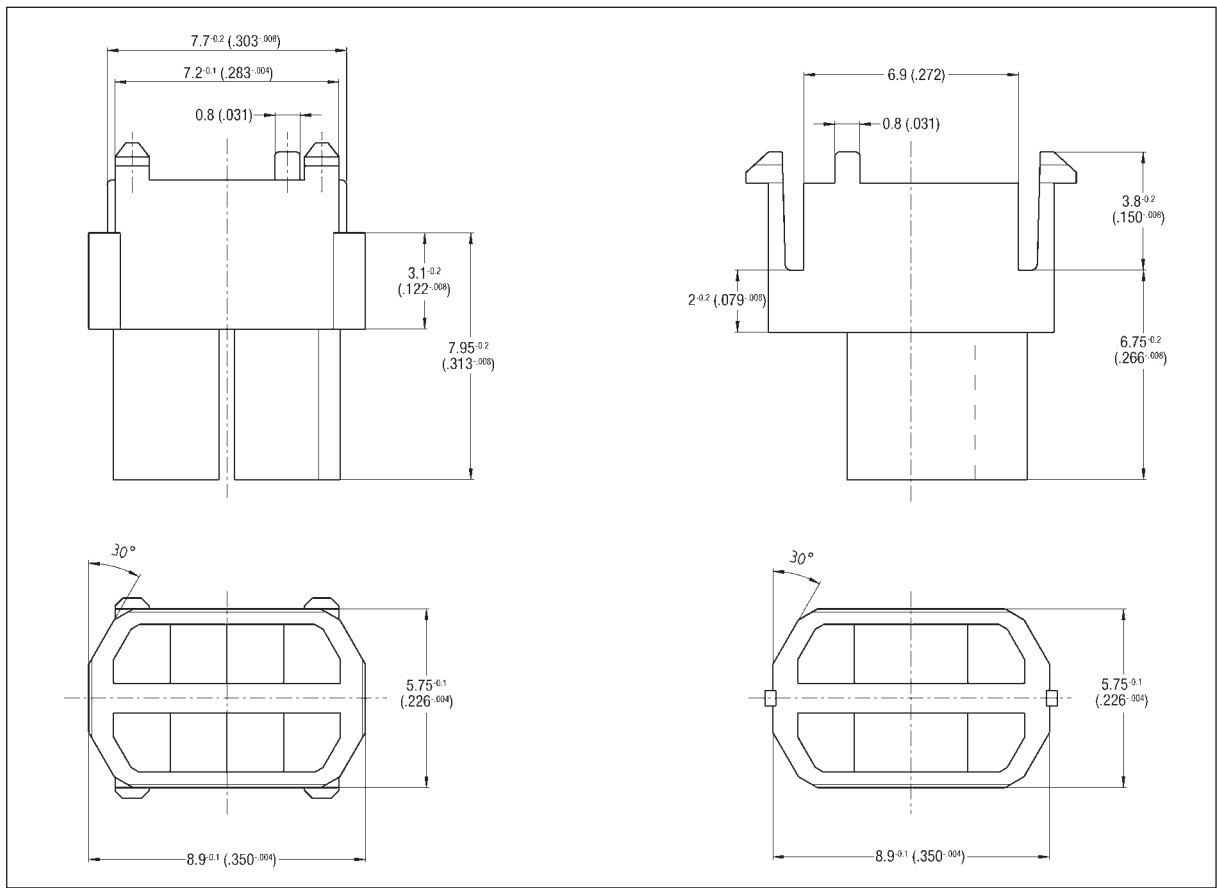

Coding Keys

Type A Male (Backplane)
Type A Female (Daughter Card)

MALE			FEMALE		
Coding Key	Color	Part Number	Coding Key	Color	Part Number
	Nut brown RAL 8011	67 7200 7014 01236		Nut brown RAL 8011	67 7200 7114 04578
	Strawberry Red Computer Telephony Spec. RAL 3018	67 7200 7014 01248		Strawberry Red Computer Telephony Spec. RAL 3018	67 7200 7114 03567
	Blue Lilac RAL 4005	67 7200 7014 01356		Blue Lilac RAL 4005	67 7200 7114 02478
	Brilliant Blue 5.0 V C-PCI RAL 5007	67 7200 7014 01567		Brilliant Blue 5.0 V C-PCI RAL 5007	67 7200 7114 02348
	Reseda Green RAL 6011	67 7200 7014 02578		Reseda Green RAL 6011	67 7200 7114 01346
	Cadmium Yellow 3.3 V C-CPI RAL 1021	67 7200 7014 03456		Cadmium Yellow 3.3 V C-CPI RAL 1021	67 7200 7114 01278
	Slate Grey RAL 7015	67 7200 7014 03467		Slate Grey RAL 7015	67 7200 7114 01258
	Steel Blue RAL 5011	67 7200 7014 03478		Steel Blue RAL 5011	67 7200 7114 01256
	Pastel Orange RAL 2003	67 7200 7014 03568		Pastel Orange RAL 2003	67 7200 7114 01247
	Ocher Yellow RAL 1024	67 7200 7014 04678		Ocher Yellow RAL 1024	67 7200 7114 01235

High Power Contacts for L and M Connectors



Series 8489

HIGH POWER PLUG CONTACT FOR PLUG SERIES 8074/8075

Variation	Termination	ØA*	Performance	Ordering Code
	SOLDER	.189 (4.80)	40 Ampere max.	60 8489 040 001 049
	SOLDER	.138 (3.50)	30 Ampere max.	60 8489 040 002 049
	SOLDER	.110 (2.80)	20 Ampere max.	60 8489 040 003 049
	SOLDER	.067 (1.70)	10 Ampere max.	60 8489 040 004 049
	CRIMP	.189 (4.80)	40 Ampere max.	60 8489 040 005 049
	CRIMP	.138 (3.50)	30 Ampere max.	60 8489 040 006 049
	CRIMP	.110 (2.80)	20 Ampere max.	60 8489 040 007 049
	CRIMP	.067 (1.70)	10 Ampere max.	60 8489 040 008 049

HIGH POWER RECEPTACLE CONTACT FOR RECEPTACLE SERIES 8074/8075

Variation	Termination	ØA*	Performance	Ordering Code
	P.C.	Contact	40 Ampere max.	60 8489 050 009 049
	SOLDER	.189 (4.80)	40 Ampere max.	60 8489 050 001 049
	SOLDER	.138 (3.50)	30 Ampere max.	60 8489 050 002 049
	SOLDER	.110 (2.80)	20 Ampere max.	60 8489 050 003 049
	SOLDER	.067 (1.70)	10 Ampere max.	60 8489 050 004 049
	CRIMP	.189 (4.80)	40 Ampere max.	60 8489 050 005 049
	CRIMP	.138 (3.50)	30 Ampere max.	60 8489 050 006 049
	CRIMP	.110 (2.80)	20 Ampere max.	60 8489 050 007 049
	CRIMP	.067 (1.70)	10 Ampere max.	60 8489 050 008 049

CRIMPING PLIER FOR HIGH POWER CONTACTS

Part Number

06 8489 001 010 0007



EXTRACTION TOOL FOR ALL CONTACT TYPES

Part Number	Length
06 8489 001 001 000	2.755 (70.00)
06 8489 001 002 000	7.874 (200.00)
66 8489 001 003 000	Replacement tip

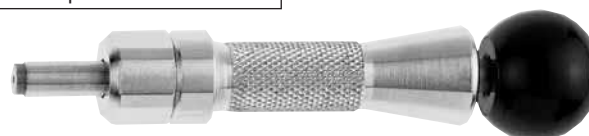

Coax Contacts for L and M Connectors



Series 8489

COAX PLUG CONTACT FOR SERIES 8074/8075

Dimensions: mm/inches

Variation	Termination		Dimensions			Wire Type	Order Code
	Outer Conductor	Inner Conductor	ØA	ØB	ØC		
	CRIMP	SOLDER	1.05/0.041	1.70/0.067	2.25/0.089	RG 196, 178	60 8489 020 001 049
	CRIMP	SOLDER	1.70/0.067	2.70/0.106	3.20/0.126	RG 179, 316 (single), RG 187	60 8489 020 002 049
	CRIMP	SOLDER	1.70/0.067	2.70/0.106	3.58/0.141	RG 316 (braided), RG 187 (double)	60 8489 020 003 049
	SOLDER	SOLDER	1.30/0.051	1.90/0.075	2.20/0.087	RG 178	60 8489 020 004 049
	SOLDER	SOLDER	2.25/0.089	2.90/0.114	3.20/0.126	RG 179	60 8489 020 005 049

COAX RECEPTACLE CONTACT FOR SERIES 8074/8075

Dimensions: mm/inches

Variation	Termination		Dimensions			Wire Type	Order Code
	Outer Conductor	Inner Conductor	ØA	ØB	ØC		
	CRIMP	SOLDER	1.70/0.067	2.70/0.106	3.55/0.140	RG 187	60 8489 030 001 049
	CRIMP	SOLDER	1.70/0.067	2.70/0.106	3.20/0.126	RG 316, RG 179, RG 188, RG 174	60 8489 030 002 049
	CRIMP	SOLDER	1.05/0.041	1.70/0.067	2.25/0.089	RG 178	60 8489 030 003 049
	SOLDER	SOLDER	2.25/0.089	2.90/0.114	3.20/0.126	RG 179	60 8489 030 004 049
	SOLDER	SOLDER	1.30/0.051	1.90/0.075	2.20/0.087	RG 178	60 8489 030 005 049
	P.C.	P.C.					60 8489 030 008 049

CRIMPING PLIER FOR COAX CONTACTS (WITHOUT CRIMPING INSERTS)

Part Number

36 8489 001 020 001



CRIMPING INSERTS

Part Number	Cable Type
66 8489 00 102 1 000	RG 196 A/U RG 178 B/U
66 8489 00 102 2 000	RG 188 A/U RG 174 A/U RG 316 /U RG 179 B/U RG 187 A/U
66 8489 00 102 3 000	RG 316 /U

Special Contacts for L and M Connectors



TECHNICAL DATA

	Coaxial Contacts	High Current Contacts
Contact Material	copper alloy	copper alloy
Contact Plating	gold over nickel	gold over nickel
Performance Class	1 - 500 mating cycles	1 - 500 mating cycles
Insulator Material	PTFE	
Temperature Range	-55°C ~ +125°C	-55°C ~ +125°C
Maximum Current	0.5 ampere	10, 20, 30, 40 ampere
Operating Voltage	250 V eff.	
Peak Voltage	750 V eff.	
Contact Resistance	3 Mohm max. (1) 10 Mohm max. (2)	< 1 Mohm max.
Insulation Resistance	10,000,000 Mohm	
Insertion Force (max.)	10 N	10 N
Retention Force (min.)	0.9 N	1.6 N
Characteristic Impedance	50 Ohm	
Working Frequency	ca. 30 GHz max. 0-10 GHz opt.	
Reflection Coefficient	max. 0.05 to 1 GHz max. 0.07 to 4 GHz max. 0.1 to 10 GHz	

(1) Outer Conductor

(2) Inner Conductor

Connectors Type A, B, C

2mm Hard-Metric Custom Design Worksheet

Series 7200



Fax To: AVX Connectors

North America: Fax: 843-444-2814
Tel: 843-946-0634

Europe: Fax: ++49 2741 299 122
Tel: ++49 2741 299-0

Asia-Pacific: Fax: (65) 350-4880
Tel: (65) 258-2833

Name _____ Title _____

Company _____ email _____

Address _____

City _____ State _____ Zip _____

Telephone _____ Fax _____

For special loading configuration for your application, use this form. Select the grid diagram that applies to the type connector style you need. Fill in each block with the pin style (from the table) that you need. Please leave unloaded positions or rows blank.

TYPE A

25	24	23	22	21	20	19	18	17	16	15	14	13	12	11	10	9	8	7	6	5	4	3	2	1	
																									z
																									a
																									b
																									c
																									d
																									e
																									f

TYPE B

25	24	23	22	21	20	19	18	17	16	15	14	13	12	11	10	9	8	7	6	5	4	3	2	1	
																									z
																									a
																									b
																									c
																									d
																									e
																									f

TYPE C

11	10	9	8	7	6	5	4	3	2	1
										z
										a
										b
										c
										d
										e
										f

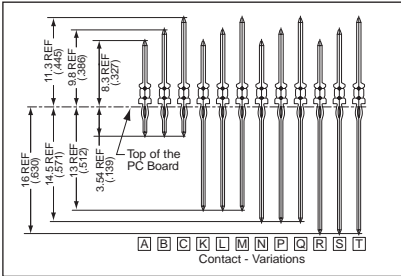

Mylar strip: Yes No

Lubrication: Yes No

Perf. Class: I 1.27 Gold/Gold
 I 1.27 Gold/Tin
 II 0.80 Gold/Gold
 II 0.80 Gold/Tin
 Gold all over

Date: _____

P/N assigned: _____

EAU: _____



Connectors Type D, E, F

2mm Hard-Metric Custom Design Worksheet

Series 8075/8077

Fax To: AVX Connectors

North America: Fax: 843-444-2814
Tel: 843-946-0634

Europe: Fax: ++44 (0)1252 770001
Tel: ++44 (0)1252 770000

Asia-Pacific: Fax: (65) 350-4880
Tel: (65) 258-2833

Name _____ Title _____

Company _____ email _____

Address _____

City _____ State _____ Zip _____

Telephone _____ Fax _____

For special loading configuration for your application, use this form. Select the grid diagram that applies to the type connector style you need. Fill in each block with the pin style (from the table) that you need. Please leave unloaded positions or rows blank.

TYPE D

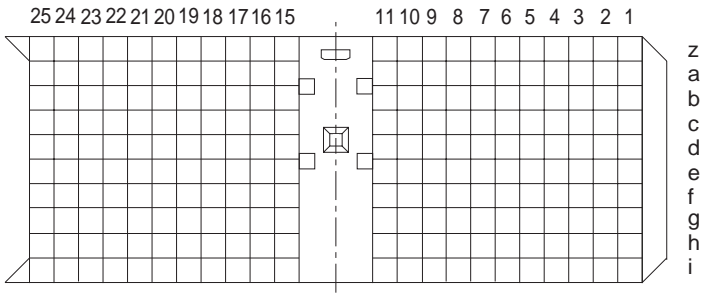

TYPE AB (7 ROW) TYPE E (10 ROW)

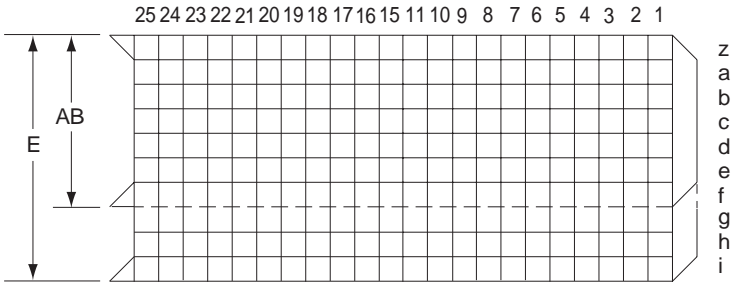

TYPE C (7 ROW) TYPE F (10 ROW)

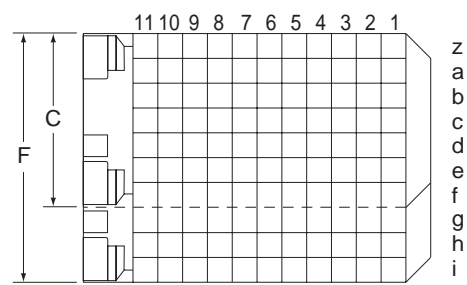

CONTACT STYLES

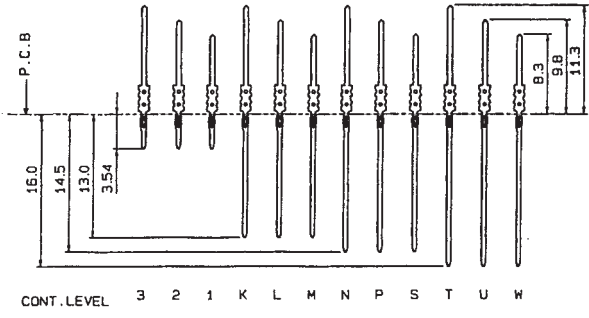

Part Number Index

Multi-Line Module Connector

2mm Hard-Metric for CompactPCI®



PART NUMBER	PAGE
06 7200 0201 00 000	49
06 7200 0202 00 000	49
06 7200 0203 00 000	49
06 7200 0204 00 000	49
06 7200 0205 00 000	49
06 8489 001 001 000	54
06 8489 001 002 000	54
06 8489 001 003 000	54
06 8489 001 010 0007	54
17 7200 055 401 012	41
17 7200 077 400 002	41
17 7200 077 401 002	41
17 7200 077 402 005	41
17 7200 077 403 005	41
17 7200 077 404 005	41
17 7200 095 300 012	39
17 7200 100 008 002	33
17 7200 110 200 012	37
17 7200 125 100 012	35
17 7200 132 211 002	37
17 7200 133 300 002	39
17 7200 133 301 002	39
17 7200 133 302 005	39
17 7200 133 303 005	39
17 7200 133 304 005	39
17 7200 154 000 002	33
17 7200 154 001 002	33
17 7200 154 002 005	33
17 7200 154 003 005	33
17 7200 154 004 005	33
17 7200 154 005 002	33
17 7200 154 006 002	33
17 7200 154 200 002	37
17 7200 154 201 002	37
17 7200 154 202 005	37
17 7200 154 203 005	37
17 7200 154 204 005	37
17 7200 175 100 002	35
17 7200 175 101 002	35
17 7200 175 102 005	35
17 7200 175 103 005	35
17 7200 175 104 005	35
17 8072 055 001 863+	48
17 8072 095 000 863+	47
17 8072 110 000 863+	47
17 8072 110 001 863+	46
17 8072 125 000 863+	47
17 8075 355 501 863+	45
17 8077 176 503 XXX+	42

PART NUMBER	PAGE
17 8077 200 504 XXX+	43
17 8077 220 501 XXX+	42
17 8077 250 502 XXX+	43
27 7200 055 400 002	19
27 7200 055 401 002	19
27 7200 055 402 002	19
27 7200 055 403 002	19
27 7200 090 007 002	21
27 7200 090 008 002	21
27 7200 090 009 002	21
27 7200 090 010 002	21
27 7200 095 300 002	15
27 7200 095 301 002	15
27 7200 095 302 002	15
27 7200 095 303 002	15
27 7200 110 000 002	11
27 7200 110 001 002	11
27 7200 110 002 002	11
27 7200 110 003 002	11
27 7200 110 200 002	13
27 7200 110 201 002	13
27 7200 110 202 002	13
27 7200 110 203 002	13
27 7200 125 100 002	17
27 7200 125 101 002	17
27 7200 125 102 002	17
27 7200 125 103 002	17
27 8071 110 003 XXX+	25
27 8071 110 013 XXX+	25
27 8071 125 003 863+	26
27 8071 125 013 863+	26
27 8072 095 001 XXX+	31
27 8072 095 011 XXX+	31
27 8072 110 000 XXX+	31
27 8072 110 001 863+	30
27 8072 110 010 XXX+	31
27 8072 110 011 863+	30
27 8072 125 000 863+	31
27 8072 125 010 863+	31
27 8075 355 011 XXX+	28
27 8075 355 012 XXX+	28
27 8077 088 001 863+	24
27 8077 088 011 863+	24
27 8077 176 001 863+	22
27 8077 176 011 863+	22
27 8077 200 000 863+	23
27 8077 200 010 863+	23
36 8489 001 020 001	55
60 8489 020 001 049	55



Part Number Index

Multi-Line Module Connector

2mm Hard-Metric for CompactPCI®

PART NUMBER	PAGE
60 8489 020 002 049	55
60 8489 020 003 049	55
60 8489 020 004 049	55
60 8489 020 005 049	55
60 8489 030 001 049	55
60 8489 030 002 049	55
60 8489 030 003 049	55
60 8489 030 004 049	55
60 8489 030 005 049	55
60 8489 030 008 049	55
60 8489 040 001 049	54
60 8489 040 002 049	54
60 8489 040 003 049	54
60 8489 040 004 049	54
60 8489 040 005 049	54
60 8489 040 006 049	54
60 8489 040 007 049	54
60 8489 040 008 049	54
60 8489 050 001 049	54
60 8489 050 002 049	54
60 8489 050 003 049	54
60 8489 050 004 049	54
60 8489 050 005 049	54
60 8489 050 006 049	54
60 8489 050 007 049	54
60 8489 050 008 049	54
60 8489 050 009 049	54
61 8074 006 001 007+	44
62 8074 006 011 007+	27
62 8074 006 111 007+	27
66 8489 00 102 1 000	55
66 8489 00 102 2 000	55
66 8489 00 102 3 000	55
67 7200 2613 00 675	19
67 7200 2613 00 675	21
67 7200 2623 00 675	15
67 7200 2633 00 675	13
67 7200 2643 00 675	11
67 7200 2653 00 675	17
67 7200 2663 00 675	21

PART NUMBER	PAGE
67 7200 6024 00 000	51
67 7200 6064 00 000	51
67 7200 6084 00 000	51
67 7200 6094 00 000	51
67 7200 6124 00 000	50
67 7200 6164 00 000	50
67 7200 6184 00 000	50
67 7200 6194 00 000	50
67 7200 6224 00 000	50
67 7200 6264 00 000	50
67 7200 6284 00 000	50
67 7200 6294 00 000	50
67 7200 6324 00 000	50
67 7200 6364 00 000	50
67 7200 6384 00 000	50
67 7200 6394 00 000	50
67 7200 6424 00 000	51
67 7200 6464 00 000	51
67 7200 6484 00 000	51
67 7200 6494 00 000	51
67 7200 7014 01236	53
67 7200 7014 01248	53
67 7200 7014 01256	53
67 7200 7014 01567	53
67 7200 7014 02578	53
67 7200 7014 03456	53
67 7200 7014 03467	53
67 7200 7014 03478	53
67 7200 7014 03568	53
67 7200 7014 04678	53
67 7200 7114 01235	53
67 7200 7114 01247	53
67 7200 7114 01256	53
67 7200 7114 01258	53
67 7200 7114 01278	53
67 7200 7114 01346	53
67 7200 7114 02348	53
67 7200 7114 02478	53
67 7200 7114 03567	53
67 7200 7114 04578	53

Connector Guide



DIN41612 / EN60603-2 Connectors



Varicon



FFC/FPC Connectors



Memory Card Components



AMERICAS

AVX Myrtle Beach, SC
Corporate Offices
Tel: 843-448-9411
FAX: 843-448-1943

AVX Northwest, WA
Tel: 360-699-8746
FAX: 360-699-8751

AVX North Central, IN
Tel: 317-848-7153
FAX: 317-844-9314

AVX Midwest, MN
Tel: 952-974-9155
FAX: 952-974-9179

AVX Mid/Pacific, CA
Tel: 510-661-4100
FAX: 510-661-4101

AVX Southwest, AZ
Tel: 602-678-0384
FAX: 602-678-0385

AVX South Central, TX
Tel: 972-669-1223
FAX: 972-669-2090

AVX Southeast, GA
Tel: 404-608-8151
FAX: 770-972-0766

AVX Canada

Tel: 905-238-3151
FAX: 905-238-0319

AVX South America
Tel: ++55-11-2193-7200
FAX: ++55-11-2193-7210

EUROPE

AVX Limited, England
European Headquarters
Tel: ++44 (0) 1252-770000
FAX: ++44 (0) 1252-770001

AVX/ELCO, England
Tel: ++44 (0) 1638-675000
FAX: ++44 (0) 1638-675002

AVX S.A., France
Tel: ++33 (1) 69-18-46-00
FAX: ++33 (1) 69-28-73-87

AVX GmbH, Germany
Tel: ++49 (0) 8131-9004-0
FAX: ++49 (0) 8131-9004-44

AVX srl, Italy
Tel: ++390 (0)2 614-571
FAX: ++390 (0)2 614-2576

AVX Czech Republic
Tel: ++420 465-358-111
FAX: ++420 465-323-010

ASIA-PACIFIC

AVX/Kyocera, Singapore
Asia-Pacific Headquarters
Tel: (65) 6286-7555
FAX: (65) 6488-9880

AVX/Kyocera, Hong Kong
Tel: (852) 2-363-3303
FAX: (852) 2-765-8185

AVX/Kyocera, Korea
Tel: (82) 2-785-6504
FAX: (82) 2-784-5411

AVX/Kyocera, Taiwan
Tel: (886) 2-2698-8778
FAX: (886) 2-2698-8777

AVX/Kyocera, Malaysia
Tel: (60) 4-228-1190
FAX: (60) 4-228-1196

Elco, Japan
Tel: 045-943-2906/7
FAX: 045-943-2910

Kyocera, Japan - AVX
Tel: (81) 75-604-3426
FAX: (81) 75-604-3425

Kyocera, Japan - KDP
Tel: (81) 75-604-3424
FAX: (81) 75-604-3425

AVX/Kyocera, Shanghai,
China
Tel: 86-21 6341 0300
FAX: 86-21 6341 0330

AVX/Kyocera, Beijing, China
Tel: 86-10 8458 3385
Fax: 86-10 8458 3382

ASIA-KED

KED, Hong Kong
Tel: (852) 2305 1080
FAX: (852) 2305 1405

KED, Shanghai
Tel: (86) 21 6859 9898
FAX: (86) 21 5887 2542

KED, Beijing
Tel: (86) 10 5869 4655
FAX: (86) 10 5869 4677

KED, South Korea
Tel: (82) 2 783 3288
FAX: (82) 2 783 3207

KED, Taiwan
Tel: (886) 2 2950 0268
FAX: (886) 2 2950 0520

KED, Singapore
Tel: (65) 6255 3122
FAX: (65) 6255 5092

Contact:



<http://www.avx.com>

S-2MMHM00M306-C