

Variable Transformers
Series 2500 • 10.0 to 25.0 Amperes

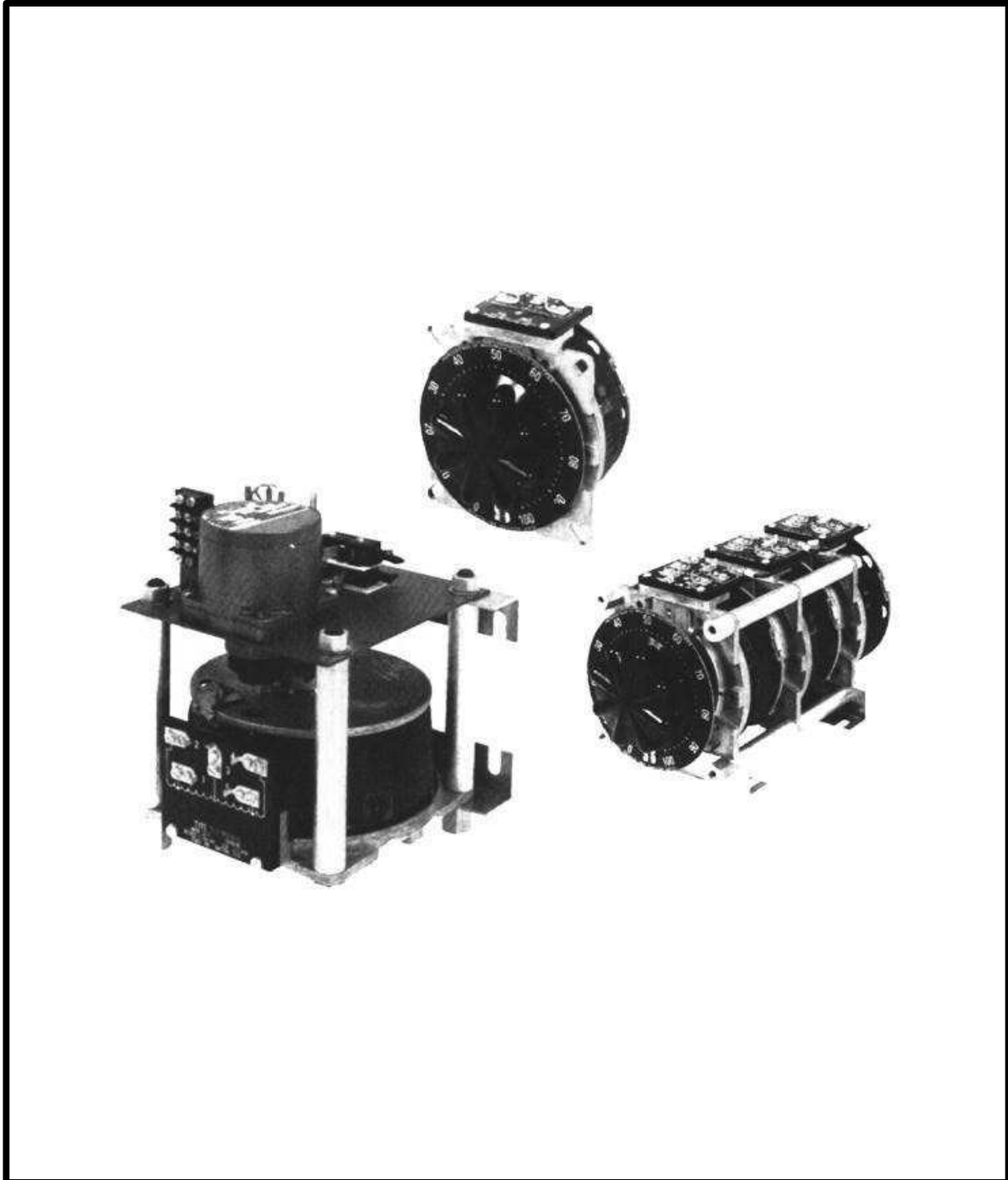

2500 Series

The 2510/2520 Series Variable Transformers represent a compact high current variable transformer design. The 2510, 120 volt unit is rated at 25 amperes for constant current loads; while the 2520, 240 volt unit is rated at 10 amperes for constant current loads. Constant impedance ratings are listed in the specifications. They can be operated at frequencies between 50 and 2000 Hertz with derating at higher than rated frequency.

Uncased models have the shaft extending from the base end. This shaft is fully adjustable and can be extended from either end for general utility mounting. Cased styles are available in either "C" style (featuring protective screening over the coil

assembly only) or the "CT" style (which also includes a terminal box cover with knock-outs to accept conduit).

Motor-driven models are available in single, two, or three ganged assemblies in cased or uncased styles as identified by the prefix "M" in the part number. If a motor driven model is ordered, be sure to prefix the part number with the desired travel time from 0 to maximum of 5, 15, 30 or 60 seconds. Example: 5M2510CT. The synchronous motor is designed for operation on 120 volts, 50/60 Hertz, single phase lines and draws approximately 0.3 amperes.

PART NUMBER		WIRING	INPUT		OUTPUT				SHAFT ROTATION FOR VOLTAGE INCREASE	TERMINAL CONNECTIONS (FOR INCREASING VOLTAGE) AS VIEWED FROM BASE END			SCHE-MATIC (Pg 8 & 9)	NET WEIGHT LBS. MAX.				
MANUALLY OPERATED	MOTOR DRIVEN		VOLTS	HERTZ	VOLTS	CONSTANT CURRENT LOAD		CONSTANT IMPEDANCE LOAD		INPUT	JUMPER	OUTPUT		MAN-UAL	MOTOR DRIVEN			
						MAX AMPS	MAX KVA	MAX AMPS								MAX KVA		
2510 2510C 2510CT	M2510+ M2510+ M2510CT+	Single Phase	120	50/60	0-120	25	3.00	30	3.6	CW	2-4	—	4-3	14	21	31		
					0-140	25	3.50	—	—	CCW	2-4	—	2-3					
2510-2 2510C-2 2510CT-2	M2510-2+ M2510C-2+ M2510CT-2+	Single Phase Series	240	50/60	0-240	25	6.00	30	7.2	CW	2-2	4-4	3-3	14 & 4	50	60		
					0-280	25	7.00	—	—	CCW	4-4	2-2	3-3					
		Three Phase Open Delta	120++	50/60	0-120	25	5.20	30	6.2	CW	1-1	4-4	3-3	14 & 5				
					0-140	25	6.06	—	—	CCW	5-5	2-2	3-3					
2510-3 2510C-3 2510CT-3	M2510-3+ M2510C-3+ M2510CT-3+	Three Phase Wye	240++	50/60	0-240	25	10.40	30	12.5	CW	2-2-2	4-4-4	3-3-3	14 & 6	68	78		
					0-280	25	12.10	—	—	CCW	4-4-4	2-2-2	3-3-3					
			60															
3PN2210B		Single Phase	120	50/60	0-140	22‡	3.08	—	—	CW	LINE CORD & RECEPTACLE			3	24 1/4	—		
2520 2520C 520CT	M2520+ M2520C+ M2520CT+	Single Phase	240	50/60	0-240	10	2.40	13	3.12	CW	2-4	—	4-3	15	21	31		
					0-280	10	2.80	—	—	CCW	2-4	—	2-3					
			120	50/60	0-280	10#	1.20§	—	—	CW	1-4	—	4-3					
2520-2 2520C-2 2520CT-2	M2520-2+ M2520C-2+ M2520CT-2+	Single Phase Series	480	50/60	0-480	10	4.80	13	6.24	CW	2-2	4-4	3-3	15 & 4	50	60		
					0-560	10	5.60	—	—	CCW	4-4	2-2	3-3					
			240	50/60	0-560	10#	2.40§	—	—	CW	1-1	4-4	3-3					
		Three Phase Open Delta	240++	50/60	0-240	10	4.20	13	5.40	CW	2-2-2	4-4	3-3-3	15 & 5				
					0-280	10	4.85	—	—	CCW	4-2-4	2-2	3-2-3					
			120++	50/60	0-280	10#	2.10§	—	—	CW	1-4-1	4-4	3-4-3					
2520-3 2520C-3 2520CT-3	M2520-3+ M2520C-3+ M2520CT-3+	Three Phase Wye	480++	50/60	0-480	10	8.30	13	10.81	CW	2-2-2	4-4-4	3-3-3	15 & 6	68	78		
					0-560	10	9.70	—	—	CCW	4-4-4	2-2-2	3-3-3					
			240++	60														
3PN2520B		Single Phase	240	50/60	0-280	10‡	2.80	—	—	CW	LINE CORD & RECEPTACLE			3	24 1/4	—		

• Jumper provided in the standard common position and should be moved or removed as required.

++ Line to line voltage

‡ Unit is fused for the constant current rating at the factory.

+ Motor driven units use terminal connections for CCW increasing voltage, as viewed from the base end. See Figure 23 on page 9 for motor wiring.

If ganged units are used in a system that ordinarily has a common neutral or ground between source and load, the neutral or ground must be connected to the common ter-

minals of the variable transformer assembly. If the system has no neutral, the load must be balanced or the transformers will be damaged.

Maximum output current in output voltage range from 0 to 25% above line voltage. At higher output voltages, the output current must be reduced according to the derating curve, Figure B, page 6.

§ Maximum KVA at maximum output voltage and corresponding derated output current. Maximum KVA for lower voltages may be calculated from derating curve Figure B, page 6.

2500 Series

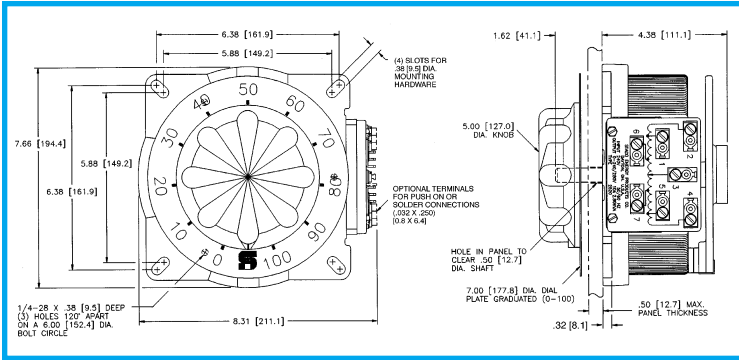

Manual Single, Uncased

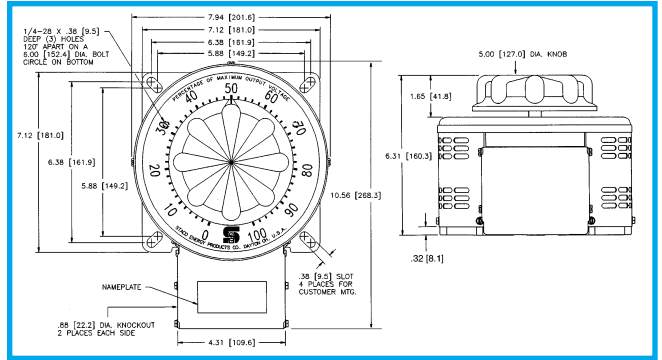

Manual Single, Cased

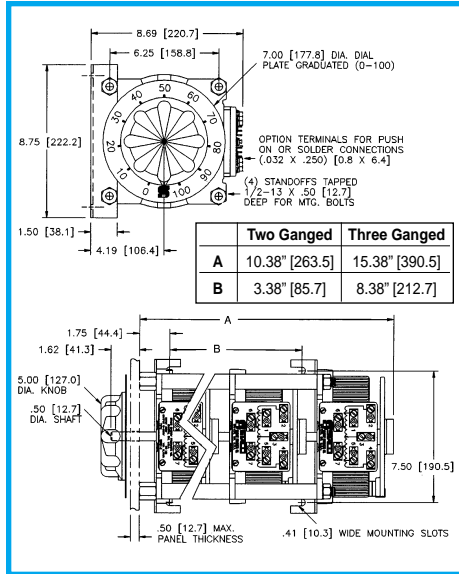
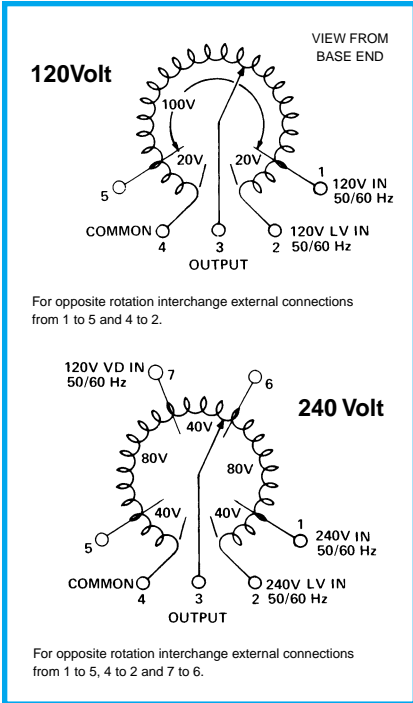

Manual Two and Three-Ganged, Uncased

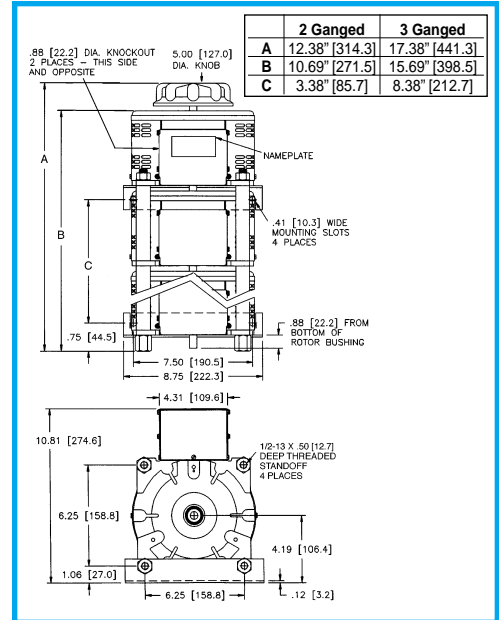

Manual Two and Three-Ganged, Cased

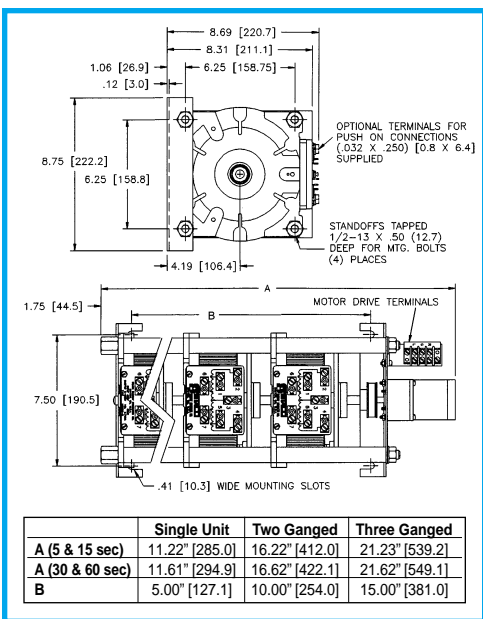

Motor-Driven Single, Two and Three-Ganged, Uncased

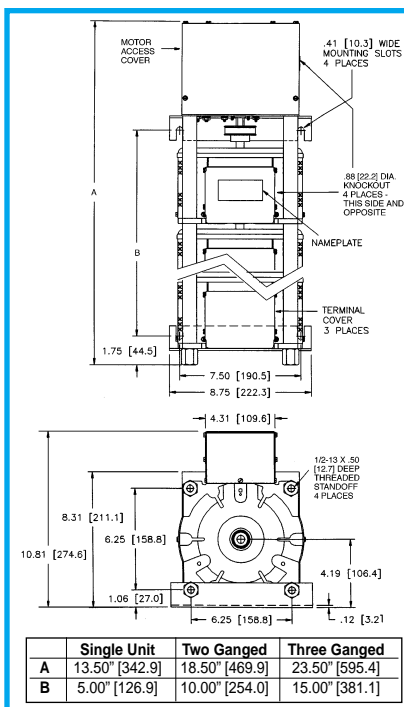

Motor-Driven Single, Two and Three-Ganged, Cased

