

2K VESA® E-EDID™ Serial EEPROM

Features:

- Single Supply with Operation Down to 2.5V
- Supports Enhanced EDID™ (E-EDID™) 1.3
- Completely Implements DDC1™/DDC2™ Interface for Monitor Identification, including Recovery to DDC1
- 2 Kbit Serial EEPROM Low-Power CMOS Technology:
 - 1 mA active current, typical
 - 10 µA standby current, typical at 5.5V
- 2-Wire Serial Interface Bus, I²C™ Compatible
- 100 kHz (2.5V) and 400 kHz (5V) Compatibility
- Self-Timed Write Cycle (including Auto-Erase)
- Hardware Write-Protect Pin
- Page Write Buffer for up to Eight Bytes
- 1,000,000 Erase Write Cycles
- Data Retention >200 years
- ESD Protection >4000V
- 8-pin PDIP and SOIC Packages
- Available Temperature Ranges:
 - Industrial (I) -40°C to +85°C
- Pb-Free and RoHS Compliant

Description:

The Microchip Technology Inc. 24LCS22A is a 256 x 8-bit dual-mode Electrically Erasable PROM (EEPROM). This device is designed for use in applications requiring storage and serial transmission of configuration and control information. Two modes of operation have been implemented: Transmit-Only mode (1 Kbit) and Bidirectional mode (2 Kbit). Upon power-up, the device will be in the Transmit-Only mode, sending a serial bit stream of the memory array from 00h to 7Fh, clocked by the VCLK pin. A valid high-to-low transition on the SCL pin will cause the device to enter the Transition mode, and look for a valid control byte on the I²C bus. If it detects a valid control byte from the master, it will switch into Bidirectional mode, with byte selectable read/write capability of the entire 2K memory array using SCL. If no control byte is received, the device will revert to the Transmit-Only mode after it receives 128 consecutive VCLK pulses while the SCL pin is idle. The 24LCS22A is available in standard 8-pin PDIP and SOIC packages. The 24LCS22A features a flexible write-protect pin which is enabled by writing to address 7Fh (usually the checksum in VESA® applications).

Package Types

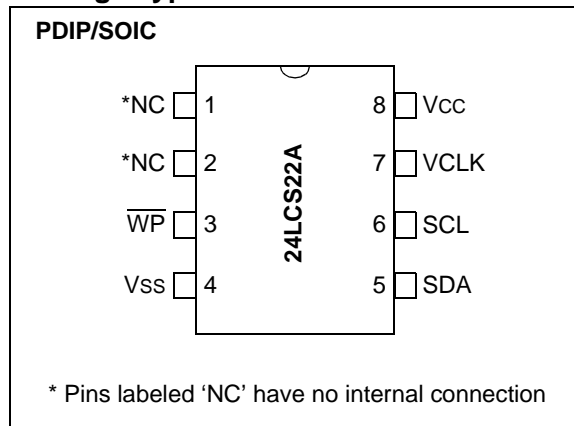

Block Diagram

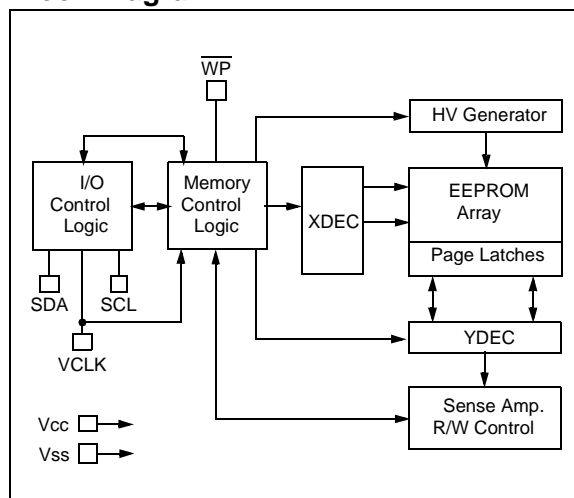

24LCS22A

1.0 ELECTRICAL CHARACTERISTICS

Absolute Maximum Ratings^(†)

V _{CC}	7.0V
All inputs and outputs w.r.t. V _{SS}	-0.6V to V _{CC} +1.0V
Storage temperature	-65°C to +150°C
Ambient temperature with power applied.....	-40°C to +125°C
ESD protection on all pins	≥ 4 kV

† **Notice:** Stresses above those listed under “Absolute Maximum Ratings” may cause permanent damage to the device. This is a stress rating only and functional operation of the device at those or any other conditions above those indicated in the operational listings of this specification is not implied. Exposure to maximum rating conditions for extended periods may affect device reliability.

TABLE 1-1: DC CHARACTERISTICS

DC CHARACTERISTICS			V _{CC} = +2.5V to 5.5V Industrial (I): T _A = -40°C to +85°C			
Param. No.	Sym	Characteristic	Min.	Max.	Units	Test Conditions
SCL and SDA pins:						
D1	V _{IH}	High-level input voltage	0.7 V _{CC}	—	V	
D2	V _{IL}	Low-level input voltage	—	0.3 V _{CC}	V	
Input levels on VCLK pin:						
D3	V _{IH}	High-level input voltage	2.0	—	V	V _{CC} ≥ 2.7V (Note)
D4	V _{IL}	Low-level input voltage	—	0.2 V _{CC}	V	V _{CC} ≤ 2.7V (Note)
D5	V _{HYS}	Hysteresis of Schmitt Trigger Inputs	.05 V _{CC}	—	V	(Note)
D6	V _{OL1}	Low-level output voltage	—	0.4	V	I _{OL} = 3 mA, V _{CC} = 2.5V (Note)
D7	V _{OL2}	Low-level output voltage	—	0.6	V	I _{OL} = 6 mA, V _{CC} = 2.5V
D8	I _{LI}	Input leakage current	—	±1	μA	V _{IN} = 0.1V to V _{CC}
D9	I _{LO}	Output leakage current	—	±1	μA	V _{OUT} = 0.1V to V _{CC}
D10	C _{IN} , C _{OUT}	Pin capacitance (all inputs/outputs)	—	10	pF	V _{CC} = 5.0V (Note) T _A = 25°C, F _{CLK} = 1 MHz
Operating current:						
D10	I _{CC WRITE}	Operating current	—	3	mA	V _{CC} = 5.5V,
D11	I _{CC READ}	Operating current	—	1	mA	V _{CC} = 5.5V, SCL = 400 kHz
D12	I _{CCS}	Standby current	—	30	μA	V _{CC} = 3.0V, SDA = SCL = V _{CC}
			—	100	μA	V _{CC} = 5.5V, SDA = SCL = V _{CC} VCLK = V _{SS}

Note: This parameter is periodically sampled and not 100% tested.

TABLE 1-2: AC CHARACTERISTICS

AC CHARACTERISTICS			V _{CC} = +2.5V to 5.5V Industrial (I): T _A = -40° C to +85° C			
Param. No.	Sym	Parameter	Min	Max	Units	Conditions
1	FCLK	Clock frequency	— —	100 400	kHz	2.5V ≤ V _{CC} ≤ 5.5V 4.5V ≤ V _{CC} ≤ 5.5V
2	THIGH	Clock high time	4000 600	— —	ns	2.5V ≤ V _{CC} ≤ 5.5V 4.5V ≤ V _{CC} ≤ 5.5V
3	TLOW	Clock low time	4700 1300	— —	ns	2.5V ≤ V _{CC} ≤ 5.5V 4.5V ≤ V _{CC} ≤ 5.5V
4	TR	SDA and SCL rise time	— —	1000 300	ns	2.5V ≤ V _{CC} ≤ 5.5V (Note 1) 4.5V ≤ V _{CC} ≤ 5.5V (Note 1)
5	TF	SDA and SCL fall time	— —	300 300	ns	(Note 1)
6	THD:STA	Start condition hold time	4000 600	— —	ns	2.5V ≤ V _{CC} ≤ 5.5V 4.5V ≤ V _{CC} ≤ 5.5V
7	TSU:STA	Start condition setup time	4700 600	— —	ns	2.5V ≤ V _{CC} ≤ 5.5V 4.5V ≤ V _{CC} ≤ 5.5V
8	THD:DAT	Data input hold time	0 0	— —	ns	(Note 2)
9	TSU:DAT	Data input setup time	250 100	— —	ns	2.5V ≤ V _{CC} ≤ 5.5V 4.5V ≤ V _{CC} ≤ 5.5V
10	TSU:STO	Stop condition setup time	4000 600	— —	ns	2.5V ≤ V _{CC} ≤ 5.5V 4.5V ≤ V _{CC} ≤ 5.5V
11	TAA	Output valid from clock (Note 2)	— —	3500 900	ns	2.5V ≤ V _{CC} ≤ 5.5V 4.5V ≤ V _{CC} ≤ 5.5V
12	TBUF	Bus free time: Time the bus must be free before a new transmission can start	4700 1300	— —	ns	2.5V ≤ V _{CC} ≤ 5.5V 4.5V ≤ V _{CC} ≤ 5.5V
13	TOF	Output fall time from V _{IH} minimum to V _{IL} maximum	— 20+0.1CB	250 250	ns	2.5V ≤ V _{CC} ≤ 5.5V (Note 1) 4.5V ≤ V _{CC} ≤ 5.5V (Note 1)
14	TSP	Input filter spike suppression (SDA and SCL pins)	— —	50 50	ns	(Notes 1 and 3)
15	TWR	Write cycle time (byte or page)	— —	10 10	ms	
16	TVAA	Output valid from VCLK	— —	2000 1000	ns	
17	TVHIGH	VCLK high time	4000 600	— —	ns	
18	TVLOW	VCLK low time	4700 1300	— —	ns	
19	TVHST	VCLK setup time	0 0	— —	ns	
20	TSPVL	VCLK hold time	4000 600	— —	ns	
21	TVHZ	Mode transition time	— —	1000 500	ns	
22	TVPU	Transmit-only power-up time	0 0	— —	ns	
23	TSPV	Input filter spike suppression (VCLK pin)	— —	100 100	ns	
24	—	Endurance	1M	—	cycles	25°C, V _{CC} = 5.0V, Block mode (Note 4)

Note 1: Not 100% tested. CB = total capacitance of one bus line in pF.

Note 2: As a transmitter, the device must provide an internal minimum delay time to bridge the undefined region (minimum 300 ns) of the falling edge of SCL to avoid unintended generation of Start or Stop conditions.

Note 3: The combined TSP and VHYS specifications are due to Schmitt Trigger inputs which provide improved noise spike suppression. This eliminates the need for a TI specification for standard operation.

Note 4: This parameter is not tested but established by characterization. For endurance estimates in a specific application, please consult the Total Endurance™ Model which can be obtained from Microchip's web site at

8-Lead Plastic Small Outline (SN) – Narrow, 3.90 mm Body [SOIC]

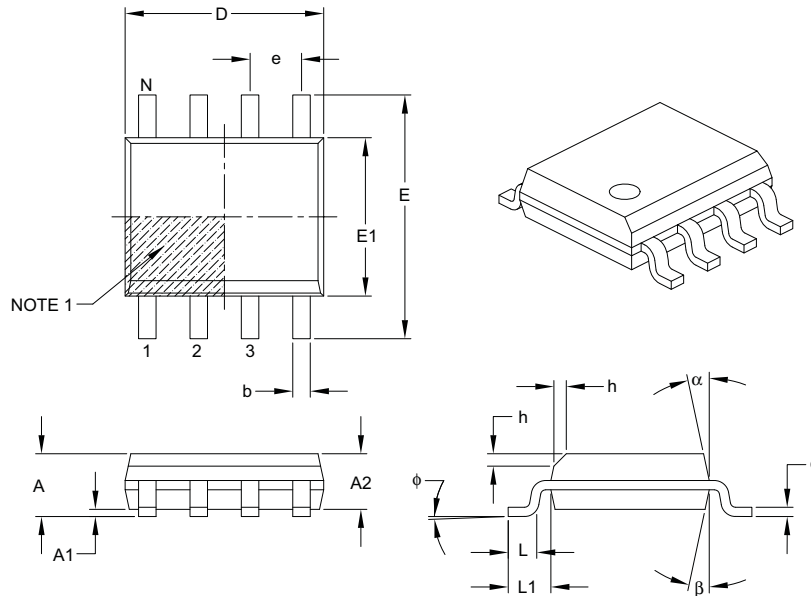

Dimension Limits	Units	MILLIMETERS		
		MIN	NOM	MAX
Number of Pins	N	8		
Pitch	e	1.27 BSC		
Overall Height	A	–	–	1.75
Molded Package Thickness	A2	1.25	–	–
Standoff §	A1	0.10	–	0.25
Overall Width	E	6.00 BSC		
Molded Package Width	E1	3.90 BSC		
Overall Length	D	4.90 BSC		
Chamfer (optional)	h	0.25	–	0.50
Foot Length	L	0.40	–	1.27
Footprint	L1	1.04 REF		
Foot Angle	ϕ	0°	–	8°
Lead Thickness	c	0.17	–	0.25
Lead Width	b	0.31	–	0.51
Mold Draft Angle Top	α	5°	–	15°
Mold Draft Angle Bottom	β	5°	–	15°

Notes:

- Pin 1 visual index feature may vary, but must be located within the hatched area.
- § Significant Characteristic.
- Dimensions D and E1 do not include mold flash or protrusions. Mold flash or protrusions shall not exceed 0.15 mm per side.
- Dimensioning and tolerancing per ASME Y14.5M.

BSC: Basic Dimension. Theoretically exact value shown without tolerances.

REF: Reference Dimension, usually without tolerance, for information purposes only.

Microchip Technology Drawing C04-057B

24LCS22A

8-Lead Plastic Small Outline (SN) – Narrow, 3.90 mm Body [SOIC]

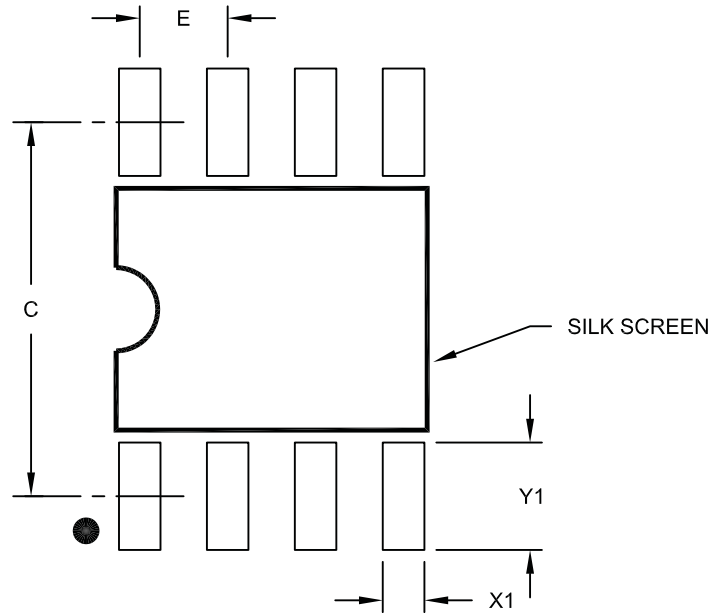

RECOMMENDED LAND PATTERN

Dimension Limits	Units	MILLIMETERS		
		MIN	NOM	MAX
Contact Pitch	E	1.27 BSC		
Contact Pad Spacing	C		5.40	
Contact Pad Width (X8)	X1			0.60
Contact Pad Length (X8)	Y1			1.55

Notes:

1. Dimensioning and tolerancing per ASME Y14.5M

BSC: Basic Dimension. Theoretically exact value shown without tolerances.

Microchip Technology Drawing No. C04-2057A

PRODUCT IDENTIFICATION SYSTEM

To order or obtain information, e.g., on pricing or delivery, refer to the factory or the listed sales office.

<u>PART NO.</u>	<u>X</u>	<u>/XX</u>
Device	Temperature Range	Package
Device: 24LCS22A: 2K VESA E-EDID Serial EEPROM 24LCS22AT: 2K VESA E-EDID Serial EEPROM (Tape and Reel)	Temperature Range: I = -40° C to +85° C	Package: P = Plastic DIP (300 mil Body), 8-Lead SN = Plastic SOIC (3.90 mm Body), 8-Lead

Examples:

- a) 24LCS22A-I/P: Industrial temperature, PDIP package.
- b) 24LCS22A-I/SN: Industrial temperature, SOIC package.
- c) 24LCS22AT-I/SN: Tape and Reel, Industrial temperature, SOIC package.