

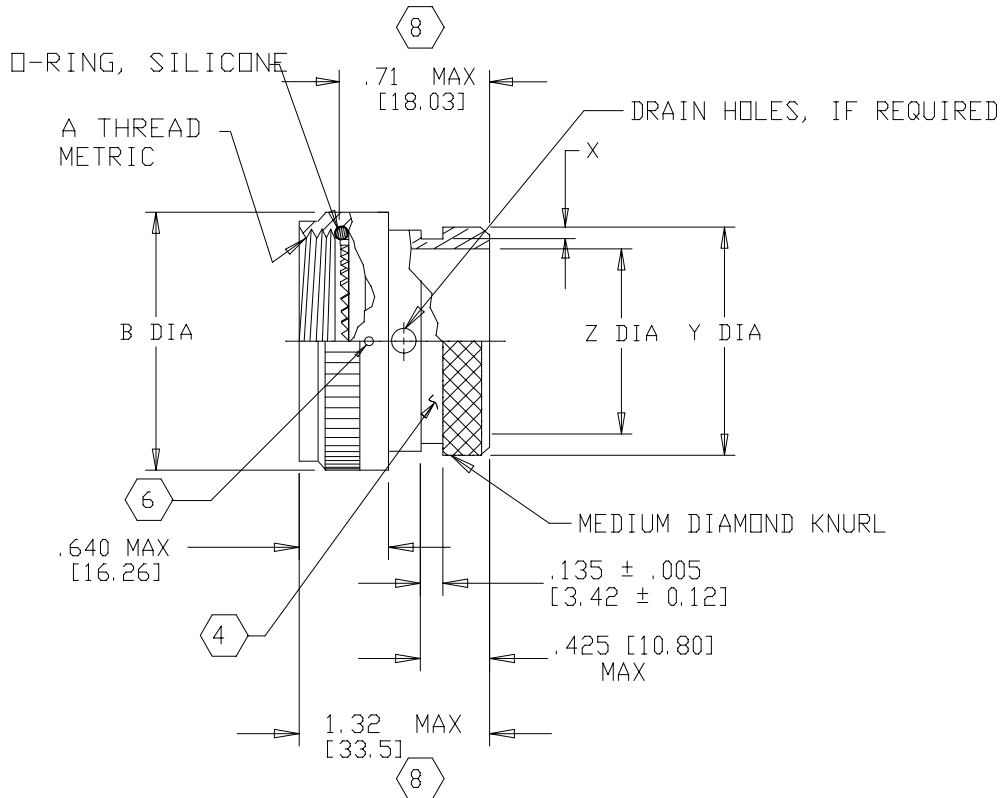

REVISIONS			
LTR	DESCRIPTION	DATE	APPROVED
G	REVISED PER ECN AD94023	8/31/94	W.C.GAY



- NOTES:
- THIS PRODUCT IS DESIGNED TO TERMINATE A HEAT SHRINKABLE LIPPED BOOT TO A CONNECTOR.
 - FOR ADDITIONAL DIMENSIONS, ORDERING INFORMATION AND MODIFICATIONS, SEE CH00-0250-004.
 - ADAPTER TO BE PERMANENTLY MARKED WITH CODE IDENT. NO. AND PART NO. (E.G.: 06090-209M412-19B).
 - KNURL INSIDE BOOT GROOVE MAY BE SUPPLIED AT MANUFACTURER'S OPTION.
 - ADAPTER MATES TO MIL-C-38999 SERIES III & IV, CLASS C, F, K, AND W, D38999/20 /24, /26, /40, /46, /47, CONNECTORS AND WHEN SO MATED SHALL PROVIDE A WATER-TIGHT SEAL MEETING THE REQUIREMENTS OF MIL-C-85049, PAR. 3.5.7.
 - COUPLING NUT SHALL HAVE 3 LOCK WIRE HOLES, 120° APART.
 - THIS IS A FUNCTIONAL EQUIVALENT OF MIL-C-85049/69.
 - WHEN GROUNDING SCREW MODIFICATION IS ORDERED .71 MAX BECOMES 1.07 MAX AND 1.32 MAX BECOMES 1.70 MAX.

SPECIFICATION CONTROL DRAWING

UNLESS OTHERWISE SPECIFIED DIMENSIONS ARE IN INCHES. METRIC DIMENSIONS ARE IN BRACKETS.	DRAWN R. RAMIREZ	DATE 03-19-93	tyco Electronics	Tyco Electronics Corporation 300 Constitution Drive Menlo Park, CA. 94025 U.S.A.	Raychem
	CHECKED	DATE			
	APPROVED	DATE	TITLE ADAPTER, SPIN COUPLING CODE 40		
	APPROVED W.C. GAY	DATE 08-31-94			
DECIMALS .XXX ± — [mm] .XX ± — [mm] .X ± — [mm]	CAD NAME \\ACAD12\209M4XX	SIZE A	CODE IDENT. NO. 06090	DWG. NO. 209M4XX	REV G
ANGLES .X ± —	THIRD ANGLE PROJECTION	DO NOT SCALE THIS DWG		SHEET 1 OF 2	

BASE PART NUMBER	SHELL SIZE 		A METRIC THREAD CLASS 6H	B DIA MAX	X +.008 -.000 [+.020] [-0.00]	Y DIA MAX	Z DIA MIN
	COML	MIL					
209M408	9	A	M12 X 1.0	.750 [19.05]	.044 [1.12]	.533 [13.54]	.250 [6.35]
209M410	11	B	M15 X 1.0	.850 [21.59]	↑	.605 [15.37]	.375 [9.52]
209M412	13	C	M18 X 1.0	1.000 [25.40]		.774 [19.66]	.500 [12.70]
209M414	15	D	M22 X 1.0	1.150 [29.2]	↓	.838 [21.29]	.620 [15.75]
209M416	17	E	M25 X 1.0	1.250 [31.75]		.963 [24.46]	.745 [18.92]
209M418	19	F	M28 X 1.0	1.400 [35.56]	.044 [1.12]	1.042 [26.47]	.812 [20.62]
209M420	21	G	M31 X 1.0	1.500 [38.10]	.069 [1.75]	1.217 [30.91]	.937 [23.80]
209M422	23	H	M34 X 1.0	1.650 [41.91]	.069 [1.75]	1.355 [34.42]	1.062 [26.97]
209M424	25	J	M37 X 1.0	1.750 [44.45]	.069 [1.75]	1.443 [36.65]	1.175 [29.85]

SIZE	CODE IDENT. NO.	DWG. NO.	REV
A	06090	209M4XX	G
DO NOT SCALE THIS DWG		CAD NAME \ACAD12\209M4X-2 SHEET 2 OF 2	