



RabbitCore RCM4500W

C-Programmable ZigBee Core Module

User's Manual

019-0161 • 090515-G

RabbitCore RCM4500W User's Manual

Part Number 019-0161 • 090515-G • Printed in U.S.A.

©2007–2009 Digi International Inc. • All rights reserved.

No part of the contents of this manual may be reproduced or transmitted in any form or by any means without the express written permission of Digi International.

Permission is granted to make one or more copies as long as the copyright page contained therein is included. These copies of the manuals may not be let or sold for any reason without the express written permission of Digi International.

Digi International reserves the right to make changes and improvements to its products without providing notice.

Trademarks

Rabbit, RabbitCore, and Dynamic C are registered trademarks of Digi International Inc.

ZigBee is a registered trademark of the ZigBee Alliance.

Digi is a registered trademark of Digi International Inc.

Rabbit 4000 is a trademark of Digi International Inc.

The latest revision of this manual is available on the Rabbit Web site, www.rabbit.com, for free, unregistered download.

Digi International Inc.

www.rabbit.com

RabbitCore RCM4500W

TABLE OF CONTENTS

Chapter 1. Introduction	1
1.1 RCM4510W Features	2
1.2 Advantages of the RCM4510W	4
1.3 Development and Evaluation Tools	5
1.3.1 RCM4510W Development Kit	5
1.3.2 Software	6
1.3.2.1 XBee Firmware	6
1.3.3 Optional Add-Ons	7
1.3.4 Online Documentation	7
Chapter 2. Getting Started	9
2.1 Install Dynamic C	9
2.2 Hardware Connections	10
2.2.1 Step 1 — Prepare the Prototyping Board for Development	10
2.2.2 Step 2 — Attach Module to Prototyping Board	11
2.2.3 Step 3 — Connect Programming Cable	12
2.2.4 Step 4 — Connect Power	13
2.3 Run a Sample Program	14
2.3.1 Troubleshooting	14
2.3.2 Run a ZigBee Sample Program	15
2.4 Where Do I Go From Here?	16
2.4.1 Technical Support	16
Chapter 3. Running Sample Programs	17
3.1 Introduction	17
3.2 Sample Programs	18
3.2.1 Serial Communication	20
3.2.2 Real-Time Clock	23
3.2.3 ZigBee Sample Programs	23
Chapter 4. Hardware Reference	25
4.1 RCM4510W Digital Inputs and Outputs	26
4.1.1 Memory I/O Interface	33
4.1.2 Other Inputs and Outputs	33
4.1.3 Auxiliary I/O	33
4.2 Serial Communication	34
4.2.1 Serial Ports	34
4.2.1.1 Using the Serial Ports	35
4.2.2 Programming Port	36
4.3 Programming Cable	37
4.3.1 Changing Between Program Mode and Run Mode	37
4.3.2 Standalone Operation of the RCM4510W	38
4.4 Auxiliary I/O	39
4.4.1 Digital I/O	39
4.4.2 A/D Converter	40
4.4.3 Other Pin Features	41

4.5 Other Hardware	42
4.5.1 Clock Doubler	42
4.5.2 Spectrum Spreader	42
4.6 Memory	43
4.6.1 SRAM	43
4.6.2 Flash EPROM	43
Chapter 5. Software Reference	45
5.1 More About Dynamic C	45
5.2 Dynamic C Function Calls	47
5.2.1 Digital I/O	47
5.2.2 Serial Communication Drivers	47
5.2.3 User Block	47
5.2.4 SRAM Use	48
5.2.5 RCM4510W Cloning	48
5.2.5.1 Including Firmware Update in Cloned Application	49
5.2.6 ZigBee Drivers	49
5.2.7 Prototyping Board Function Calls	50
5.2.7.1 Board Initialization	50
5.2.7.2 Alerts	51
5.2.8 Auxiliary I/O Pins Function Calls	52
5.2.8.1 Digital I/O	54
5.2.8.2 Analog Inputs	55
5.3 Upgrading Dynamic C	56
5.3.1 Add-On Modules	56
Chapter 6. Using the ZigBee Features	57
6.1 Introduction to the ZigBee Protocol	57
6.1.1 ZNet vs. ZB Firmware	58
6.2 ZigBee Sample Programs	59
6.2.1 Setting Up the Digi XBee USB Coordinator	59
6.2.2 Setting up Sample Programs	61
6.3 Using the Sleep Mode	65
6.4 Dynamic C Function Calls	67
6.5 Where Do I Go From Here?	67
Appendix A. RCM4510W Specifications	69
A.1 Electrical and Mechanical Characteristics	70
A.1.1 XBee RF Module	74
A.1.2 Headers	75
A.2 Rabbit 4000 DC Characteristics	76
A.3 I/O Buffer Sourcing and Sinking Limit	77
A.4 Bus Loading	77
A.5 Conformal Coating	80
A.6 Jumper Configurations	81
Appendix B. Prototyping Board	83
B.1 Introduction	84
B.1.1 Prototyping Board Features	85
B.2 Mechanical Dimensions and Layout	87
B.3 Power Supply	88
B.4 Using the Prototyping Board	89
B.4.1 Adding Other Components	91
B.4.2 Measuring Current Draw	91
B.4.3 Analog Features	92
B.4.4 Serial Communication	92
B.4.4.1 RS-232	92
B.5 Prototyping Board Jumper Configurations	94

Appendix C. Power Supply	97
C.1 Power Supplies.....	97
C.1.1 Battery Backup.....	97
C.1.2 Battery-Backup Circuit.....	98
C.1.3 Reset Generator.....	98
C.1.4 XBee RF Module Power Supply.....	99
C.2 Powerdown Mode.....	99
Appendix D. Additional Configuration Instructions	101
D.1 XBee RF Module Firmware Downloads.....	101
D.1.1 Dynamic C v. 10.44 and Later.....	101
D.1.2 Dynamic C v. 10.21 (RCM4510W preview and standard versions).....	102
D.1.3 Dynamic C v. 10.11 (RCM4510W preview version only).....	103
D.2 Digi [®] XBee USB Configuration.....	104
D.2.1 Additional Reference Information.....	106
D.2.2 Update Digi [®] XBee USB Firmware.....	106
Index	107
Schematics	111

1. INTRODUCTION

The RCM4510W next-generation RabbitCore modules add ZigBee®/802.15.4 functionality to the existing Rabbit® 4000 microprocessor features to allow you to create a low-cost, low-power, embedded wireless control and communications solution for your embedded control system. The Rabbit® 4000 microprocessor features include hardware DMA, clock speeds of up to 60 MHz, I/O lines shared with up to six serial ports and four levels of alternate pin functions that include variable-phase PWM, auxiliary I/O, quadrature decoder, and input capture. Coupled with more than 500 new opcode instructions that help to reduce code size and improve processing speed, this equates to a core module that is fast, efficient, and the ideal solution for a wide range of wireless embedded applications.

The Development Kit has the essentials that you need to design your own wireless microprocessor-based system, and includes a complete Dynamic C software development system. This Development Kit also contains a Prototyping Board that will allow you to evaluate the RCM4510W modules and to prototype circuits that interface to the RCM4510W modules. You will also be able to write and test software for these modules.

In addition to onboard ZigBee/802.15.4 functionality, the RCM4510W model has a Rabbit 4000 microprocessor operating at 29.49 MHz, static RAM, flash memory, two clocks (main oscillator and timekeeping), and the circuitry necessary for reset and management of battery backup of the Rabbit 4000's internal real-time clock and the static RAM. One 50-pin header brings out the Rabbit 4000 I/O bus lines, parallel ports, and serial ports. A separate 14-pin auxiliary I/O header brings out up to nine additional I/O pins (up to four of which may be configured as analog inputs) made possible by the onboard XBee RF module.

The RCM4510W receives its +3.3 V power from the customer-supplied motherboard on which it is mounted. The RCM4510W can interface with all kinds of CMOS-compatible digital devices through the motherboard.

1.1 RCM4510W Features

- Small size: 1.84" × 2.85" × 0.54"
(47 mm × 72 mm × 14 mm)
- Microprocessor: Rabbit 4000 running at 29.49 MHz
- Up to 40 general-purpose I/O lines configurable with up to four alternate functions
- Up to 9 additional general-purpose I/O lines (up to four of which may be set up as analog inputs) available through the XBee RF module
- 3.3 V I/O lines with low-power modes down to 2 kHz
- Six CMOS-compatible serial ports — four ports are configurable as a clocked serial port (SPI), and two ports are configurable as SDLC/HDLC serial ports.
- Alternate I/O bus can be configured for 8 data lines and 6 address lines (shared with parallel I/O lines)
- 512K flash memory, 512K data SRAM
- Real-time clock
- Watchdog supervisor

Currently there is one production model with a choice of XBee firmware. Table 1 summarizes its main features.

Table 1. RCM4510W Features

Feature	RCM4510W	
Microprocessor	Rabbit [®] 4000 at 29.49 MHz	
Flash Memory	512K	
Data SRAM	512K	
Serial Ports	6 shared high-speed, CMOS-compatible ports: 6 are configurable as asynchronous serial ports; 4 are configurable as clocked serial ports (SPI); 2 are configurable as SDLC/HDLC serial ports; 1 asynchronous serial port is shared with the XBee RF module 1 asynchronous serial port is used during programming	
XBee RF Module	Digi International [®] XBee [®] ZB (802.15.4 standard, ISM 2.4 GHz)	
XBee Firmware	ZNet 2.5	RCM4510W (ZNet) (20-101-1207)
	ZigBee PRO	RCM4510W (ZB) (20-101-1269)

Section 1.3.2.1 provides additional information about the two types of XBee firmware.

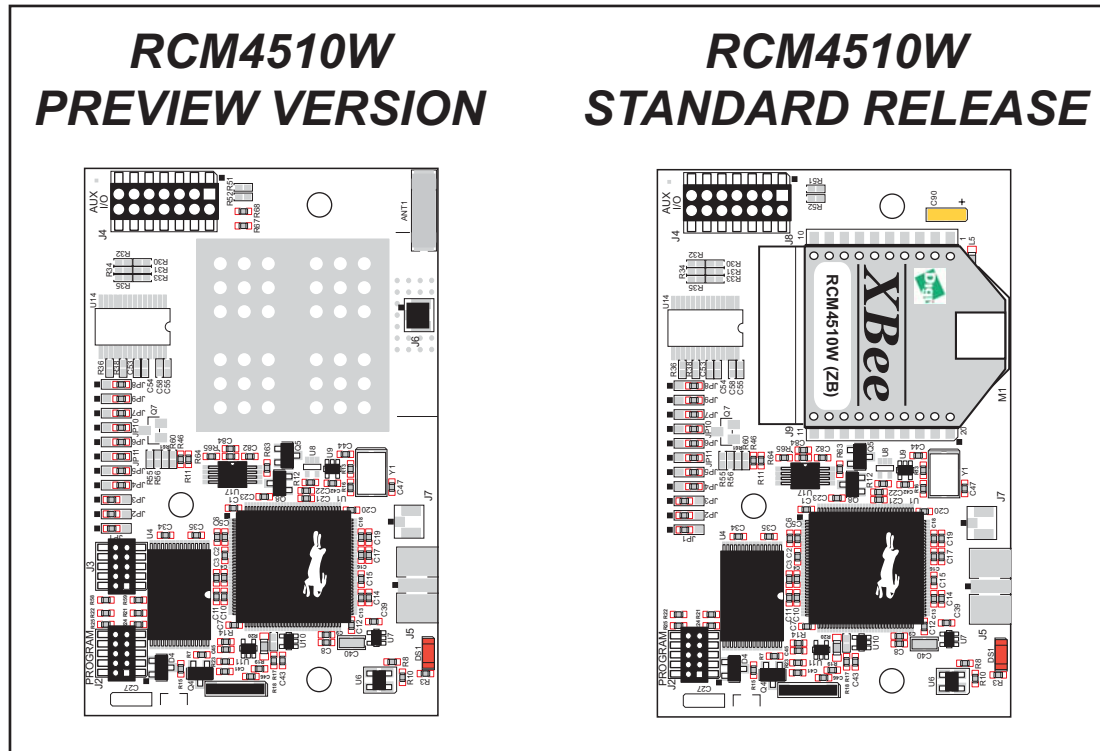

Figure 1. RCM4510W Versions

There are two versions of the RCM4510W model—the *standard release*, available after April, 2007, is identical in form and function to the *preview version*. The difference between them is that the RF module is made of discrete onboard components in the preview version, and is included in the pluggable Digi International® XBee® RF module on the standard release. The height of the preview version is also about 0.01” (0.2 mm) less than that of the standard release; Rabbit recommends that you use the dimensions for the standard release specified in this manual in your design. *The preview version has not undergone certification testing and is intended for development purposes only. The preview version will no longer be offered once the standard release is available.*

NOTE: At the present time the Digi International® XBee® RF modules used with the RCM4510W are not compatible with other XBee® and XBee PRO® RF modules such as those used with Rabbit’s ZigBee®/802.15.4 Application Kit

The RCM4510W is programmed over a standard PC USB port through a programming cable supplied with the Development Kit.

NOTE: The RabbitLink cannot be used to program the RCM4510W or other RabbitCore modules based on the Rabbit 4000 microprocessor.

Appendix A provides detailed specifications for the RCM4510W.

1.2 Advantages of the RCM4510W

- Fast time to market using a fully engineered, “ready-to-run/ready-to-program” micro-processor core.
- Competitive pricing when compared with the alternative of purchasing and assembling individual components.
- Easy C-language program development and debugging
- Rabbit Field Utility to download compiled Dynamic C .bin files, and cloning board options for rapid production loading of programs.
- Generous memory size allows large programs with tens of thousands of lines of code, and substantial data storage.
- Reference application uses a low-cost, low-power ZigBee/802.15.4 infrastructure to connect Rabbit-based devices
- Supports ZigBee/802.15.4 point-to-point, point-to-multipoint, and mesh topologies
- Easily scalable for commercial deployment applications
- RCM4510W can function as a network coordinator, router, or end device

1.3 Development and Evaluation Tools

1.3.1 RCM4510W Development Kit

The RCM4510W Development Kit contains the hardware essentials you will need to use the RCM4510W module. The items in the Development Kit and their use are as follows.

- RCM4510W module.
- Prototyping Board.
- Universal AC adapter, 12 V DC, 1 A (includes Canada/Japan/U.S., Australia/N.Z., U.K., and European style plugs). Development Kits sold in North America may contain an AC adapter with only a North American style plug.
- USB programming cable with 10-pin header.
- 10-pin header to DB9 serial cable.
- 14-pin IDC socket connector with bare leads ribbon cable.
- Digi[®] XBee USB (used as ZigBee coordinator).
- *Dynamic C*[®] CD-ROM, with complete product documentation on disk.
- *Getting Started* instructions.
- A bag of accessory parts for use on the Prototyping Board.
- *Rabbit 4000 Processor Easy Reference* poster.
- Registration card.

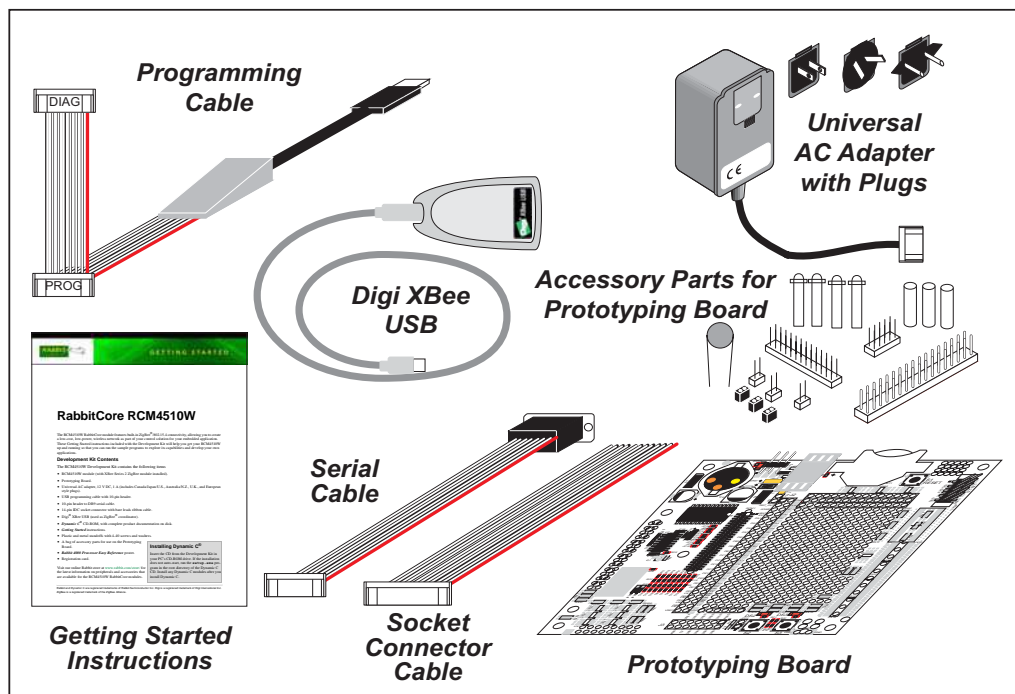

Figure 2. RCM4510W Development Kit

1.3.2 Software

The RCM4510W preview version is programmed using version 10.11 or later of Dynamic C, and the standard version requires version 10.21 or later. A compatible version is included on the Development Kit CD-ROM.

Starting with Dynamic C version 10.40, Dynamic C includes the popular μ C/OS-II real-time operating system, point-to-point protocol (PPP), FAT file system, RabbitWeb, and other select libraries. Rabbit also offers for purchase the Rabbit Embedded Security Pack featuring the Secure Sockets Layer (SSL) and a specific Advanced Encryption Standard (AES) library.

In addition to the Web-based technical support included at no extra charge, a one-year telephone-based technical support module is also available for purchase. Visit our Web site at www.rabbit.com or contact your Rabbit sales representative or authorized distributor for further information.

1.3.2.1 XBee Firmware

There are two types of XBee firmware available for the RCM4510W — ZNet 2.5 and ZigBee PRO. The firmware preloaded at the factory on your RCM4510W is indicated with the model number and is reflected in different part numbers (see Table 1). A label on the XBee RF module identifies the factory-installed firmware type. Older RCM4510W modules shipped with ZNet firmware and do not have a sticker on their XBee RF module.

RCM4510W (ZNet)

RCM4510W (ZB)

- ZNet 2.5 is a networking solution that was developed around an earlier draft of the ZigBee standard, and will work only with the MaxStream or Digi International® XBee® RF modules used with the RCM4510W or with the preview version of the RCM4510W. Applications built around ZNet 2.5 may be upgraded to the ZB solution by loading the ZB firmware (standard release RCM4510W RabbitCore modules only) and by recompiling the application using Dynamic C v. 10.46 or later.
- ZB firmware was developed using the ZigBee PRO feature set and provides the most advanced ZigBee networking capabilities that will interface with any other devices based on the ZigBee PRO standard adopted in 2007.

Dynamic C v. 10.46 and later versions support the ZB firmware with a 64-bit extended PAN ID instead of a 16-bit PAN ID

Rabbit recommends ZB firmware for new customers and new applications.

NOTE: While both ZNet 2.5 and ZB firmware types are technically ZigBee, the protocol layer in them is different and devices with one type of firmware will not function in a network with devices using the other firmware.

1.3.3 Optional Add-Ons

Rabbit has a Mesh Network Add-On Kit available for the RCM4510W.

- Mesh Network Add-On Kit (Part No. 101-1272)
 - ▶ Digi® XBee USB (used as ZigBee coordinator)
 - ▶ Two XBee ZB RF modules
 - ▶ Two RF Interface modules
 - ▶ Digi® XBee USB and serial cables

The XBee ZB RF module is installed on the RF Interface module, which can be connected via an RS-232 serial connection to a Windows PC for setup. The Mesh Network Add-On Kit enables you to add additional devices to explore a ZigBee mesh network.

Contact your authorized Rabbit distributor or your sales representative for more information, or visit our [Web site](#).

1.3.4 Online Documentation

The online documentation is installed along with Dynamic C, and an icon for the documentation menu is placed on the workstation's desktop. Double-click this icon to reach the menu. If the icon is missing, use your browser to find and load **default.htm** in the **docs** folder, found in the Dynamic C installation folder.

The latest versions of all documents are always available for free, unregistered download from our Web sites as well.

2. GETTING STARTED

This chapter describes the RCM4510W hardware in more detail, and explains how to set up and use the accompanying Prototyping Board.

NOTE: This chapter (and this manual) assume that you have the RCM4510W Development Kit. If you purchased an RCM4510W module by itself, you will have to adapt the information in this chapter and elsewhere to your test and development setup.

2.1 Install Dynamic C

To develop and debug programs for the RCM4510W modules (and for all other Rabbit hardware), you must install and use Dynamic C.

If you have not yet installed Dynamic C version 10.11 (or a later version), do so now by inserting the Dynamic C CD from the Development Kit in your PC's CD-ROM drive. If autorun is enabled, the CD installation will begin automatically.

If autorun is disabled or the installation does not start, use the Windows **Start | Run** menu or Windows Disk Explorer to launch **setup.exe** from the root folder of the CD-ROM.

The installation program will guide you through the installation process. Most steps of the process are self-explanatory.

Dynamic C uses a COM (serial) port to communicate with the target development system. The installation allows you to choose the COM port that will be used. The default selection is COM1. You may select any available port for Dynamic C's use. If you are not certain which port is available, select COM1. This selection can be changed later within Dynamic C.

NOTE: The installation utility does not check the selected COM port in any way. Specifying a port in use by another device (mouse, modem, etc.) may lead to a message such as "**could not open serial port**" when Dynamic C is started.

Once your installation is complete, you will have up to three new icons on your PC desktop. One icon is for Dynamic C, another opens the documentation menu, and the third is for the Rabbit Field Utility, a tool used to download precompiled software to a target system.

If you have purchased any of the optional Dynamic C modules, install them after installing Dynamic C. The modules may be installed in any order. You must install the modules in the same directory where Dynamic C was installed.

2.2 Hardware Connections

There are three steps to connecting the Prototyping Board for use with Dynamic C and the sample programs:

1. Prepare the Prototyping Board for Development.
2. Attach the RCM4510W module to the Prototyping Board.
3. Connect the programming cable between the RCM4510W and the PC.
4. Connect the power supply to the Prototyping Board.

2.2.1 Step 1 — Prepare the Prototyping Board for Development

Snap in four of the plastic standoffs supplied in the bag of accessory parts from the Development Kit in the holes at the corners on the bottom side of the Prototyping Board as shown in Figure 3.

NOTE: Pay attention to use the hole that is pointed out towards the bottom left of the Prototyping Board since the hole below it is used for a standoff when mounting the RCM4510W on the Prototyping Board.

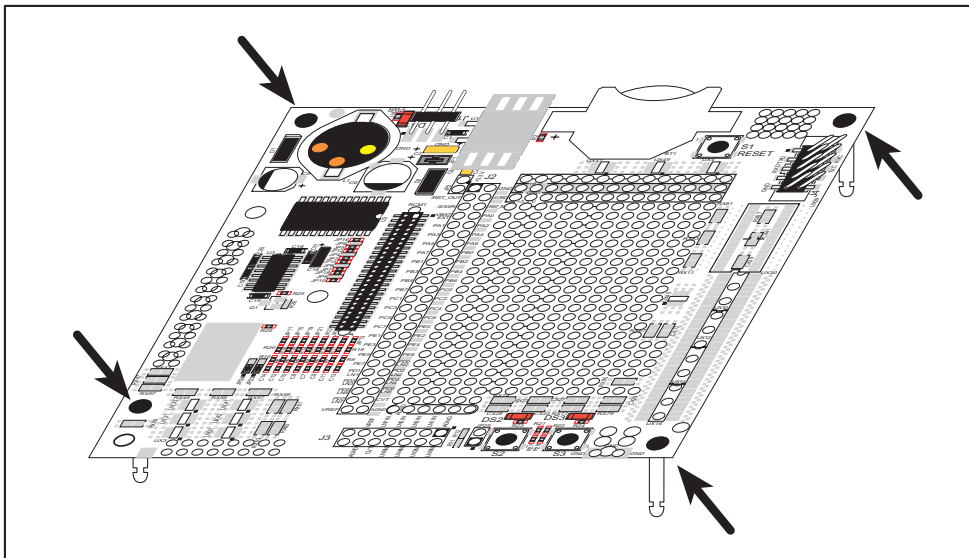

Figure 3. Insert Standoffs

2.2.2 Step 2 — Attach Module to Prototyping Board

Turn the RCM4510W module so that the mounting holes line up with the corresponding holes on the Prototyping Board with the programming header at the top right. Insert the metal standoffs as shown in Figure 4, secure them from the bottom using the 4-40 screws and washers, then insert the module's header J1 on the bottom side into socket RCM1 on the Prototyping Board.

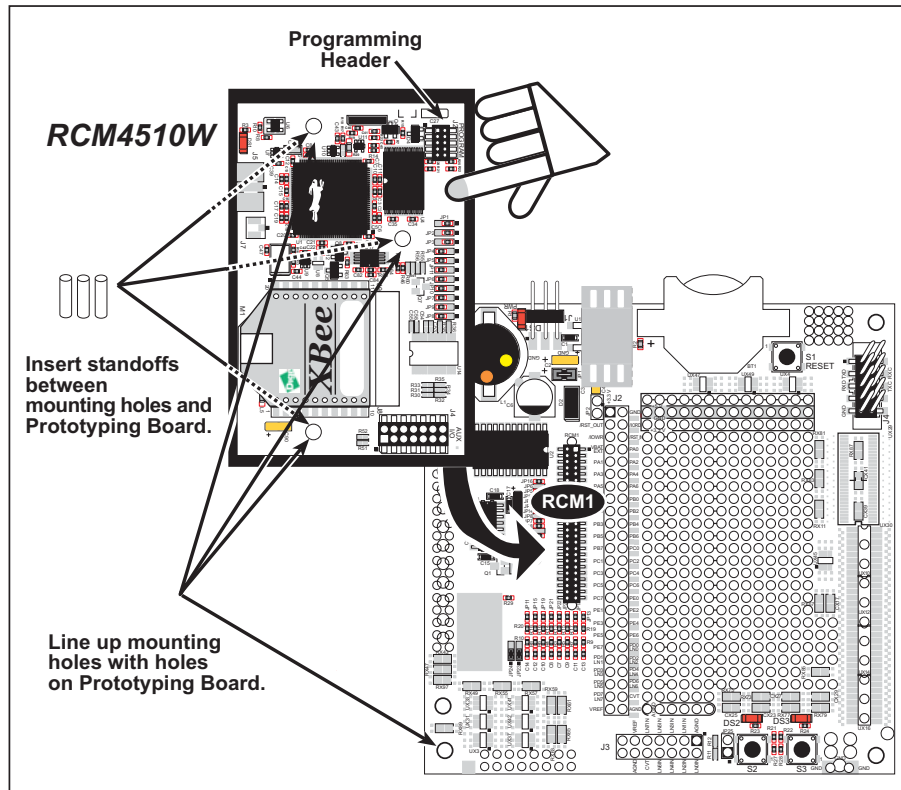
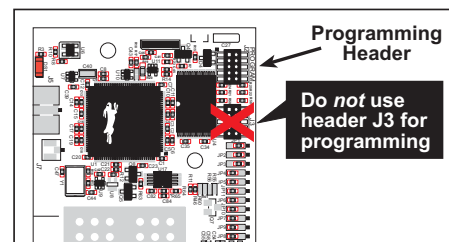

Figure 4. Install the Module on the Prototyping Board

NOTE: It is important that you line up the pins on header J1 of the module exactly with socket RCM1 on the Prototyping Board. The header pins may become bent or damaged if the pin alignment is offset, and the module will not work. Permanent electrical damage to the module may also result if a misaligned module is powered up.

Press the module's pins gently into the Prototyping Board socket—press down in the area above the header pins. For additional integrity, you may secure the RCM4510W to the standoffs from the top using the remaining three 4-40 screws and washers.

NOTE: If you are using the preview version of the RCM4510W, do not connect the programming cable to header J3 (shown below the programming header at right). Header J3 is used only by the factory.



2.2.3 Step 3 — Connect Programming Cable

The programming cable connects the module to the PC running Dynamic C to download programs and to monitor the module during debugging.

Connect the 10-pin connector of the programming cable labeled **PROG** to header J2 on the RCM4510W as shown in Figure 5. Be sure to orient the marked (usually red) edge of the cable towards pin 1 of the connector. (Do not use the **DIAG** connector, which is used for a standard serial connection.)

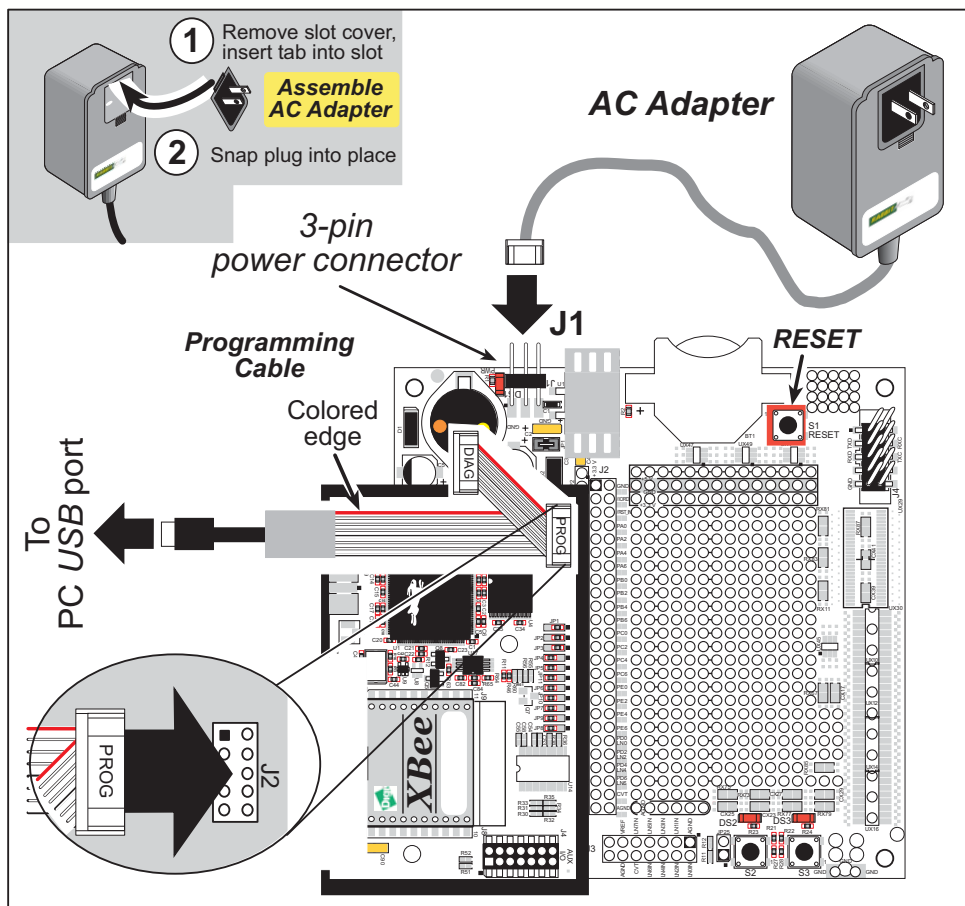

Figure 5. Connect Programming Cable and Power Supply

NOTE: Never disconnect the programming cable by pulling on the ribbon cable. Carefully pull on the connector to remove it from the header.

Connect the other end of the programming cable to an available USB port on your PC or workstation.

Your PC should recognize the new USB hardware, and the LEDs in the shrink-wrapped area of the USB programming cable will flash — if you get an error message, you will have to install USB drivers. Drivers for Windows XP are available in the Dynamic C Drivers\Rabbit USB Programming Cable\WinXP_2K folder — double-click **DPInst.exe** to install the USB drivers. Drivers for other operating systems are available online at www.ftdichip.com/Drivers/VCP.htm.

2.2.4 Step 4 — Connect Power

Once all the other connections have been made, you can connect power to the Prototyping Board.

First, prepare the AC adapter for the country where it will be used by selecting the appropriate plug. The RCM4510W Development Kit presently includes Canada/Japan/U.S., Australia/N.Z., U.K., and European style plugs. Snap in the top of the plug assembly into the slot at the top of the AC adapter as shown in Figure 5, then press down on the spring-loaded clip below the plug assembly to allow the plug assembly to click into place. Release the clip to secure the plug assembly in the AC adapter.

Connect the AC adapter to 3-pin header J1 on the Prototyping Board as shown in Figure 5. The connector may be attached either way as long as it is not offset to one side—the center pin of J1 is always connected to the positive terminal, and either edge pin is ground.

Plug in the AC adapter. The **PWR** LED on the Prototyping Board next to the power connector at J1 should light up. The RCM4510W and the Prototyping Board are now ready to be used.

NOTE: A **RESET** button is provided on the Prototyping Board next to the battery holder to allow a hardware reset without disconnecting power.

To power down the Prototyping Board, unplug the power connector from J1. You should disconnect power before making any circuit adjustments in the prototyping area, changing any connections to the board, or removing the RCM4510W from the Prototyping Board.

2.3 Run a Sample Program

If you already have Dynamic C installed, you are now ready to test your programming connections by running a sample program. Start Dynamic C by double-clicking on the Dynamic C icon on your desktop or in your **Start** menu.

You may have to select the COM port assigned to the USB programming cable on your PC. In Dynamic C, select **Options > Project Options**, then select this COM port on the “Communications” tab. Then check “Use USB to Serial Converter” in “Serial Options.” Click **OK** to save the settings.

Find the file **PONG.C**, which is in the Dynamic C **SAMPLES** folder. To run the program, open it with the **File** menu, then compile and run it by pressing **F9**. The **STDIO** window will open on your PC and will display a small square bouncing around in a box.

2.3.1 Troubleshooting

If you receive the message **Could Not Open Serial Port**, check that the COM port assigned to the USB programming cable was identified and set up in Dynamic C as described in the preceding section.

If you receive the message **No Rabbit Processor Detected**, the programming cable may be connected to the wrong COM port, a connection may be faulty, or the target system may not be powered up. First, check to see that the power LED on the Prototyping Board is lit. If the LED is lit, check both ends of the programming cable to ensure that it is firmly plugged into the PC and the programming header on the RCM4510W with the marked (colored) edge of the programming cable towards pin 1 of the programming header. Ensure that the module is firmly and correctly installed in its connectors on the Prototyping Board.

If Dynamic C appears to compile the BIOS successfully, but you then receive a communication error message when you compile and load a sample program, it is possible that your PC cannot handle the higher program-loading baud rate. Try changing the maximum download rate to a slower baud rate as follows.

- Locate the **Serial Options** dialog on the “Communications” tab in the Dynamic C **Options > Project Options** menu. Select a slower Max download baud rate.

If a program compiles and loads, but then loses target communication before you can begin debugging, it is possible that your PC cannot handle the default debugging baud rate. Try lowering the debugging baud rate as follows.

- Locate the **Serial Options** dialog on the “Communications” tab in the Dynamic C **Options > Project Options** menu. Choose a lower debug baud rate.

Press **<Ctrl-Y>** to force Dynamic C to recompile the BIOS. You should receive a **Bios compiled successfully** message once this step is completed successfully.

2.3.2 Run a ZigBee Sample Program

This section explains how to run a sample program in which the RCM4510W is used in its default setup as a router and the Digi® XBee USB is used as the ZigBee coordinator.

1. Connect the Digi® XBee USB acting as a ZigBee coordinator to an available USB port on your PC or workstation. Your PC should recognize the new USB hardware.
2. Find the file **AT_INTERACTIVE.C**, which is in the Dynamic C **SAMPLES\XBee** folder. To run the program, open it with the **File** menu, then compile and run it by pressing **F9**. The Dynamic C **STDIO** window will open to display a list of AT commands. Type **MENU** to redisplay the menu of commands.

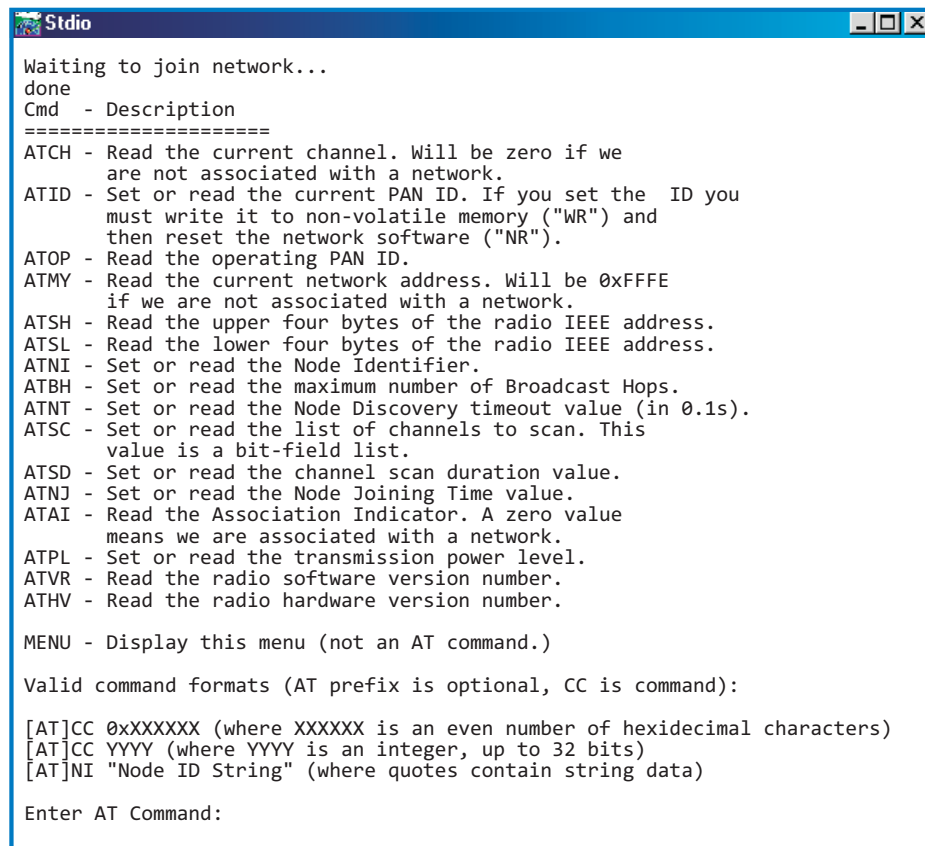

```
Stdio
Waiting to join network...
done
Cmd - Description
=====
ATCH - Read the current channel. Will be zero if we
      are not associated with a network.
ATID - Set or read the current PAN ID. If you set the ID you
      must write it to non-volatile memory ("WR") and
      then reset the network software ("NR").
ATOP - Read the operating PAN ID.
ATMY - Read the current network address. Will be 0xFFFF
      if we are not associated with a network.
ATSH - Read the upper four bytes of the radio IEEE address.
ATSL - Read the lower four bytes of the radio IEEE address.
ATNI - Set or read the Node Identifier.
ATBH - Set or read the maximum number of Broadcast Hops.
ATNT - Set or read the Node Discovery timeout value (in 0.1s).
ATSC - Set or read the list of channels to scan. This
      value is a bit-field list.
ATSD - Set or read the channel scan duration value.
ATNJ - Set or read the Node Joining Time value.
ATAI - Read the Association Indicator. A zero value
      means we are associated with a network.
ATPL - Set or read the transmission power level.
ATVR - Read the radio software version number.
ATHV - Read the radio hardware version number.

MENU - Display this menu (not an AT command.)

Valid command formats (AT prefix is optional, CC is command):
[AT]CC 0XXXXXX (where XXXXX is an even number of hexadecimal characters)
[AT]CC YYYY (where YYYY is an integer, up to 32 bits)
[AT]NI "Node ID String" (where quotes contain string data)

Enter AT Command:
```

Appendix D provides additional configuration information if you experience conflicts while doing development simultaneously with more than one ZigBee coordinator, or if you wish to install new firmware. Different firmware must be installed to use the RCM4510W as either a coordinator or as an end device.

2.4 Where Do I Go From Here?

If the sample program ran fine, you are now ready to go on to the sample programs in Chapter 3 and to develop your own applications. The sample programs can be easily modified for your own use. The user's manual also provides complete hardware reference information and software function calls for the RCM4510W series of modules and the Prototyping Board.

For advanced development topics, refer to the *Dynamic C User's Manual*, also in the online documentation set. *An Introduction to ZigBee* provides background information on the ZigBee protocol, and is available on the CD and on our [Web site](#).

2.4.1 Technical Support

NOTE: If you purchased your RCM4510W through a distributor or through a Rabbit partner, contact the distributor or partner first for technical support.

If there are any problems at this point:

- Use the Dynamic C **Help** menu to get further assistance with Dynamic C.
- Check the Rabbit Technical Bulletin Board and forums at www.rabbit.com/support/bb/ and at www.rabbitcom/forums/.
- Use the Technical Support e-mail form at www.rabbit.com/support/.

3. RUNNING SAMPLE PROGRAMS

To develop and debug programs for the RCM4510W (and for all other Rabbit hardware), you must install and use Dynamic C. This chapter provides a tour of its major features with respect to the RCM4510W.

3.1 Introduction

To help familiarize you with the RCM4510W modules, Dynamic C includes several sample programs. Loading, executing, and studying these programs will give you a solid hands-on overview of the RCM4510W's capabilities, as well as a quick start with Dynamic C as an application development tool.

This chapter provides sample programs that illustrate the digital I/O and serial capabilities of the RCM4510W RabbitCore module. Section 6.2 discusses the sample programs that illustrate the ZigBee features.

NOTE: The sample programs assume that you have at least an elementary grasp of the C language. If you do not, see the introductory pages of the *Dynamic C User's Manual* for a suggested reading list.

In order to run the sample programs discussed in this chapter and elsewhere in this manual,

1. Your module must be plugged in to the Prototyping Board as described in Chapter 2, "Getting Started."
2. Dynamic C must be installed and running on your PC.
3. The programming cable must connect the programming header on the module to your PC.
4. Power must be applied to the module through the Prototyping Board.

Refer to Chapter 2, "Getting Started," if you need further information on these steps.

To run a sample program, open it with the **File** menu, then compile and run it by pressing **F9**.

Each sample program has comments that describe the purpose and function of the program. Follow the instructions at the beginning of the sample program.

More complete information on Dynamic C is provided in the *Dynamic C User's Manual*.

3.2 Sample Programs

Of the many sample programs included with Dynamic C, several are specific to the RCM4510W modules. These programs will be found in the **SAMPLES\RCM4500W** folder.

- **CONTROLLED.C**—Demonstrates use of the digital outputs by having you turn LEDs DS2 and DS3 on the Prototyping Board on or off from the **STDIO** window on your PC.

Parallel Port B bit 2 = LED DS2

Parallel Port B bit 3 = LED DS3

Once you compile and run **CONTROLLED.C**, the following display will appear in the Dynamic C **STDIO** window.

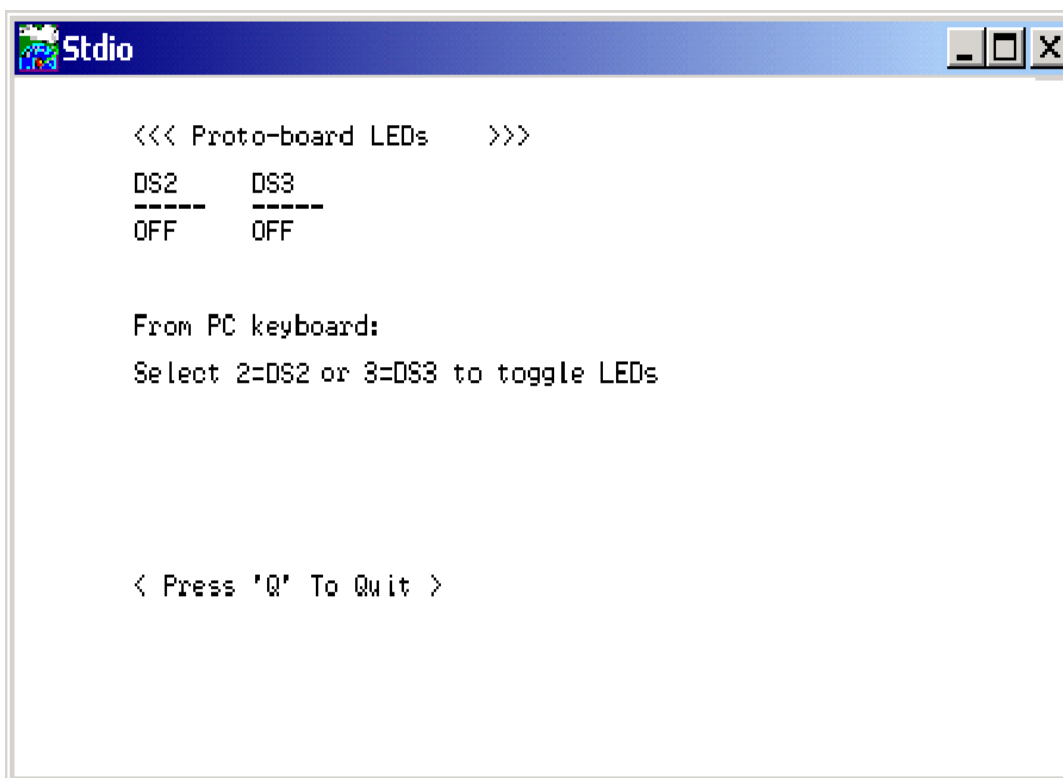

```
<<< Proto-board LEDs >>>
DS2  DS3
----  ----
OFF   OFF

From PC keyboard:
Select 2=DS2 or 3=DS3 to toggle LEDs

< Press 'Q' To Quit >
```

Press “2” or “3” on your keyboard to select LED DS2 or DS3 on the Prototyping Board. Then follow the prompt in the Dynamic C **STDIO** window to turn the LED ON or OFF. A logic low will light up the LED you selected.

- **FLASHLED1.C**—demonstrates the use of assembly language to flash LEDs DS2 and DS3 on the Prototyping Board at different rates. Once you have compiled and run this program, LEDs DS2 and DS3 will flash on/off at different rates.
- **FLASHLED2.C**—demonstrates the use of cofunctions and costatements to flash LEDs DS2 and DS3 on the Prototyping Board at different rates. Once you have compiled and run this program, LEDs DS2 and DS3 will flash on/off at different rates.

- **TAMPERDETECTION.C**—demonstrates how to detect an attempt to enter the bootstrap mode. When an attempt is detected, the battery-backed onchip-encryption RAM on the Rabbit 4000 is erased. This battery-backed onchip-encryption RAM can be useful to store data such as an AES encryption key from a remote location.

This sample program shows how to load and read the battery-backed onchip-encryption RAM and how to enable a visual indicator.

Once this sample is compiled and running (you pressed the **F9** key while the sample program is open), remove the programming cable and press the reset button on the Prototyping Board to reset the module. LEDs DS2 and DS3 will be flashing on and off.

Now press switch S2 to load the battery-backed RAM with the encryption key. The LEDs are now on continuously. Notice that the LEDs will stay on even when you press the reset button on the Prototyping Board.

Reconnect the programming cable briefly and unplug it again to simulate an attempt to access the onchip-encryption RAM. The LEDs will be flashing because the battery-backed onchip-encryption RAM has been erased. Notice that the LEDs will continue flashing even when you press the reset button on the Prototyping Board.

You may press switch S2 again and repeat the last steps to watch the LEDs.

- **TOGGLESWITCH.C**—demonstrates the use of costatements to detect switch presses using the press-and-release method of debouncing. LEDs DS2 and DS3 on the Prototyping Board are turned on and off when you press switches S2 and S3. S2 and S3 are controlled by PB4 and PB5 respectively.

Once you have loaded and executed these five programs and have an understanding of how Dynamic C and the RCM4510W modules interact, you can move on and try the other sample programs.

3.2.1 Serial Communication

The following sample programs are found in the `SAMPLES\RCM4500W\SERIAL` folder.

- **FLOWCONTROL.C**—This program demonstrates how to configure Serial Port D for CTS/RTS flow control with serial data coming from Serial Port C (TxC) at 115,200 bps. The serial data received are displayed in the **STDIO** window.

To set up the Prototyping Board, you will need to tie TxD and RxD together on the RS-232 header at J4, and you will also tie TxC and RxC together using the jumpers supplied in the Development Kit as shown in the diagram.

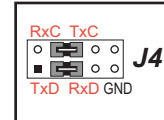

A repeating triangular pattern should print out in the **STDIO** window. The program will periodically switch flow control on or off to demonstrate the effect of flow control.

If you have two Prototyping Boards with modules, run this sample program on the sending board, then disconnect the programming cable and reset the sending board so that the module is operating in the Run mode. Connect TxC, TxD, and GND on the sending board to RxC, RxD, and GND on the other board, then, with the programming cable attached to the other module, run the sample program.

- **PARITY.C**—This program demonstrates the use of parity modes by repeatedly sending byte values 0–127 from Serial Port C to Serial Port D. The program will switch between generating parity or not on Serial Port C. Serial Port D will always be checking parity, so parity errors should occur during every other sequence.

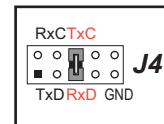

To set up the Prototyping Board, you will need to tie TxC and RxD together on the RS-232 header at J4 using one of the jumpers supplied in the Development Kit as shown in the diagram.

The Dynamic C **STDIO** window will display the error sequence.

- **SERDMA.C**—This program demonstrates using DMA to transfer data from a circular buffer to the serial port and vice versa. The Dynamic C **STDIO** window is used to view or clear the buffer.

Before you compile and run the sample program, you will need to connect the RS-232 header at J4 to your PC as shown in the diagram using the serial to DB9 cable supplied in the Development Kit.

Once you have compiled and run the sample program, start Tera Term or another terminal emulation program to connect to the selected PC serial port at a baud rate of 115,200 bps. You can observe the output in the Dynamic C **STDIO** window as you type in Tera Term, and you can also use the Dynamic C **STDIO** window to clear the buffer.

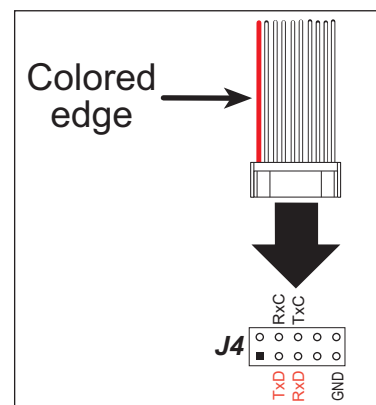

The Tera Term utility can be downloaded from hp.vector.co.jp/authors/VA002416/teraterm.html.

- **SIMPLE3WIRE.C**—This program demonstrates basic RS-232 serial communication. Lower case characters are sent on TxC, and are received by RxD. The received characters are converted to upper case and are sent out on TxD, are received on RxC, and are displayed in the Dynamic C **STDIO** window.

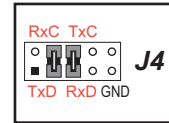

To set up the Prototyping Board, you will need to tie TxD and RxC together on the RS-232 header at J4, and you will also tie RxD and TxC together using the jumpers supplied in the Development Kit as shown in the diagram.

- **SIMPLE5WIRE.C**—This program demonstrates 5-wire RS-232 serial communication with flow control on Serial Port D and data flow on Serial Port C.

To set up the Prototyping Board, you will need to tie TxD and RxD together on the RS-232 header at J4, and you will also tie TxC and RxC together using the jumpers supplied in the Development Kit as shown in the diagram.

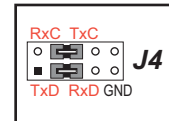

Once you have compiled and run this program, you can test flow control by disconnecting the TxD jumper from RxD while the program is running. Characters will no longer appear in the **STDIO** window, and will display again once TxD is connected back to RxD.

If you have two Prototyping Boards with modules, run this sample program on the sending board, then disconnect the programming cable and reset the sending board so that the module is operating in the Run mode. Connect TxC, TxD, and GND on the sending board to RxC, RxD, and GND on the other board, then, with the programming cable attached to the other module, run the sample program. Once you have compiled and run this program, you can test flow control by disconnecting TxD from RxD as before while the program is running. Since the J4 header locations on the two Prototyping Boards are connected with wires, there are no slip-on jumpers at J4 on either Prototyping Board.

- **SWITCHCHAR.C**—This program demonstrates transmitting and then receiving an ASCII string on Serial Ports C and D. It also displays the serial data received from both ports in the **STDIO** window.

To set up the Prototyping Board, you will need to tie TxD and RxC together on the RS-232 header at J4, and you will also tie RxD and TxC together using the jumpers supplied in the Development Kit as shown in the diagram.

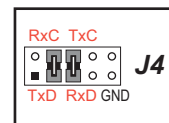

Once you have compiled and run this program, press and release switches S2 and S3 on the Prototyping Board. The data sent between the serial ports will be displayed in the **STDIO** window.

- **IOCONFIG_SWITCHECHO.C**—This program demonstrates how to set up Serial Ports E and F, which then transmit and then receive an ASCII string when switch S2 or S3 is pressed. The echoed serial data are displayed in the Dynamic C **STDIO** window.

Note that the I/O lines that carry the Serial Port E and F signals are not the Rabbit 4000 defaults. The Serial Port E and F I/O lines are configured by calling the library function `serEFconfig()` that was generated by the Rabbit 4000 **IOCONFIG.EXE** utility program.

Note that the **RCM45_29MHZ_IOCONFIG.LIB** library generated by **IOCONFIG.EXE** to support this sample program is provided in the Dynamic C **SAMPLES\RCM4500W\SERIAL** folder.

Serial Port E is configured to use Parallel Port E bits PE6 and PE7. These signals are available on the Prototyping Board's Module Extension Header (header J2).

Serial Port F is configured to use Parallel Port C bits PC2 and PC3. These signals are available on the Prototyping Board's RS-232 connector (header J4).

Serial Port D is left in its default configuration, using Parallel Port C bits PC0 and PC1. These signals are available on the Prototyping Board's RS-232 connector (header J4). Serial Port D transmits and then receives an ASCII string with Serial Port F when switch S3 is pressed.

To set up the Prototyping Board, you will need to tie TxC and RxD together on the RS-232 header at J4 using the jumpers supplied in the Development Kit; you will also tie TxE (PE6) and RxE (PE7) together with a soldered wire or with a wire jumper if you have soldered in the IDC header supplied with the accessory parts in the Development Kit.

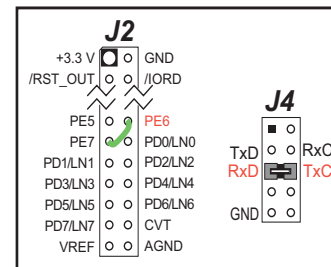

Once you have compiled and run this program, press and release switches S2 or S3 on the Prototyping Board. The data echoed between the serial ports will be displayed in the **STDIO** window.

3.2.2 Real-Time Clock

If you plan to use the real-time clock functionality in your application, you will need to set the real-time clock. Use the **SETRTCKB.C** sample program from the Dynamic C **SAMPLES\RTCLOCK** folder, and follow the onscreen prompts. The **RTC_TEST.C** sample program in the Dynamic C **SAMPLES\RTCLOCK** folder provides additional examples of how to read and set the real-time clock.

3.2.3 ZigBee Sample Programs

Section 6.2 describes the sample programs associated with the XBee RF module.

4. HARDWARE REFERENCE

Chapter 4 describes the hardware components and principal hardware subsystems of the RCM4510W. Appendix A, “RCM4510W Specifications,” provides complete physical and electrical specifications.

Figure 6 shows the Rabbit-based subsystems designed into the RCM4510W.

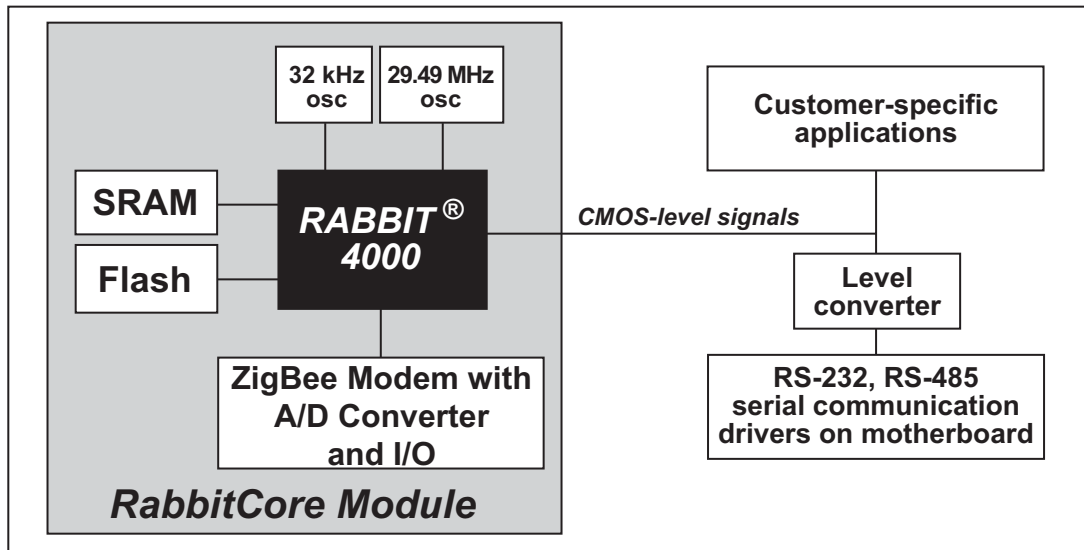

Figure 6. RCM4510W Subsystems

4.1 RCM4510W Digital Inputs and Outputs

Figure 7 shows the RCM4510W pinouts for headers J1 and J4.

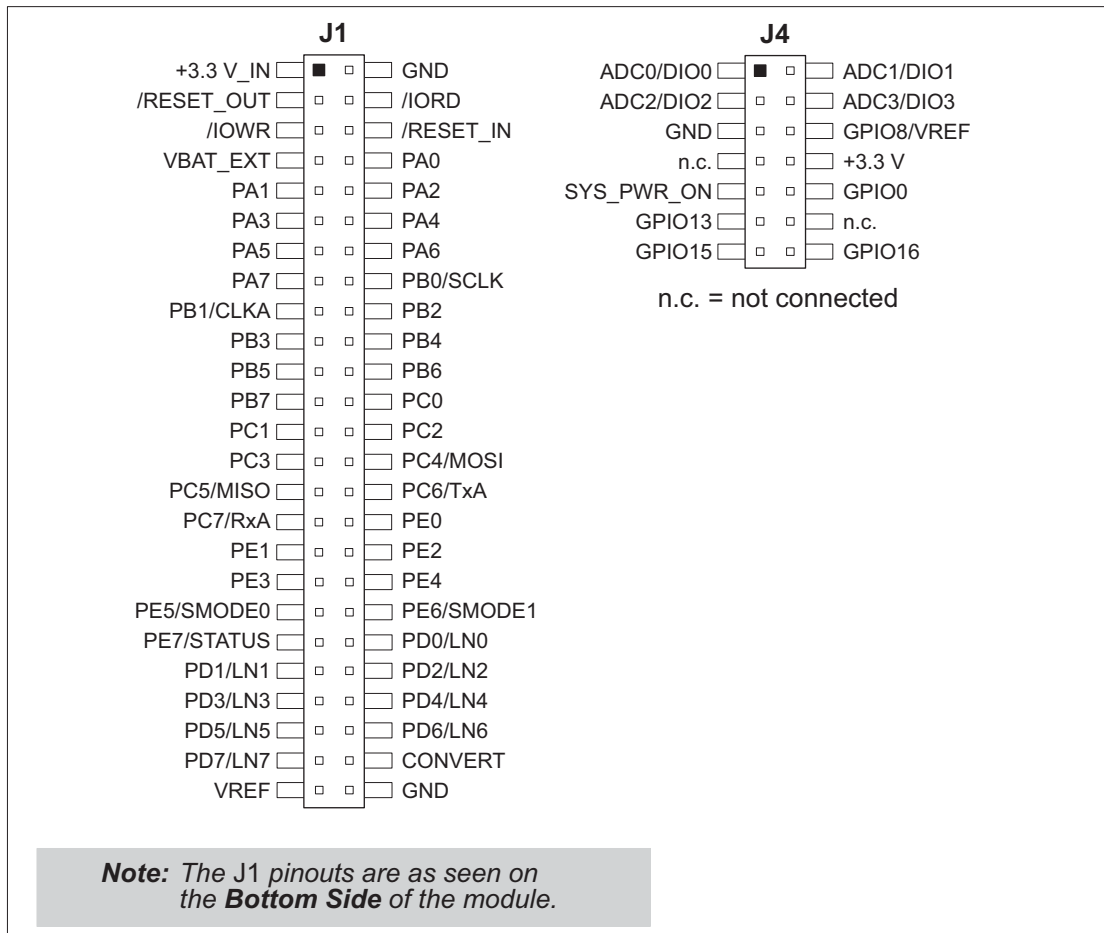

Figure 7. RCM4510W Pinout

Header J1 is a standard 2 × 25 IDC header with a nominal 1.27 mm pitch, and header J4 is a standard 2 × 7 IDC header with a nominal 2 mm pitch.

Figure 8 shows the use of the Rabbit 4000 microprocessor ports in the RCM4510W modules.

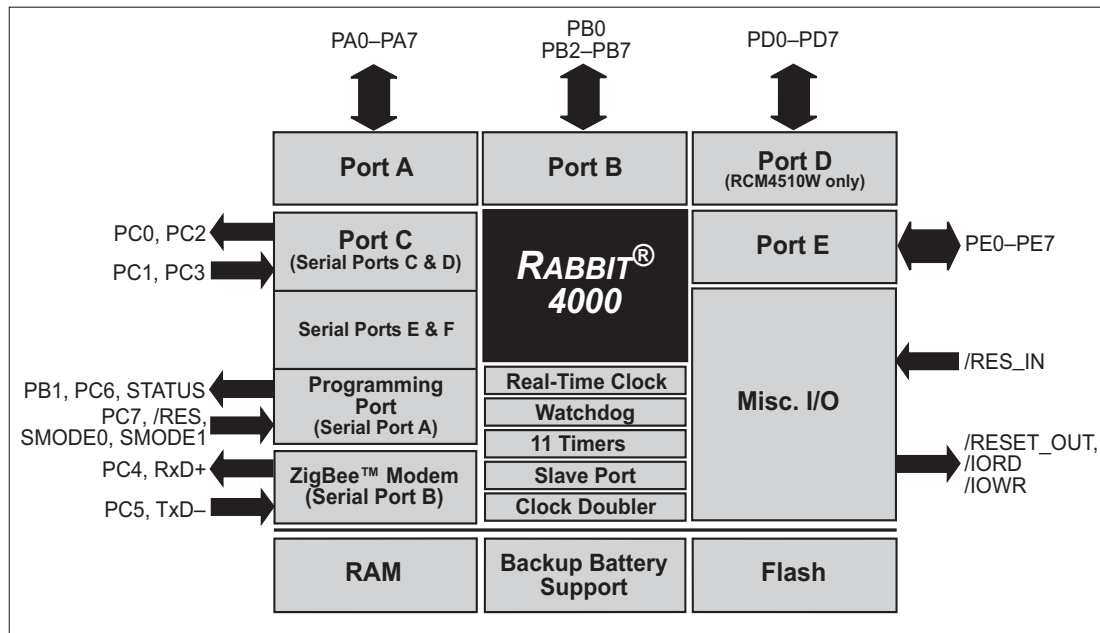

Figure 8. Use of Rabbit 4000 Ports

The ports on the Rabbit 4000 microprocessor used in the RCM4510W are configurable, and so the factory defaults can be reconfigured. Table 2 lists the Rabbit 4000 factory defaults and the alternate configurations.

Table 2. RCM4510W Pinout Configurations

Pin	Pin Name	Default Use	Alternate Use	Notes	
Header J1	1	+3.3 V_IN			
	2	GND			
	3	/RES_OUT	Reset output	Reset input	Reset output from Reset Generator or external reset input
	4	/IORD	Output		External I/O read strobe
	5	/IOWR	Output		External I/O write strobe
	6	/RESET_IN	Input		Input to Reset Generator
	7	VBAT_EXT	Battery input		
	8–15	PA[0:7]	Input/Output	Slave port data bus (SD0–SD7) External I/O data bus (ID0–ID7)	
	16	PB0	Input/Output	SCLK External I/O Address IA6	SCLKB (reserved for future use)
	17	PB1	Input/Output	SCLKA External I/O Address IA7	Programming port CLKA
	18	PB2	Input/Output	/SWR External I/O Address IA0	
	19	PB3	Input/Output	/SRD External I/O Address IA1	
	20	PB4	Input/Output	SA0 External I/O Address IA2	
	21	PB5	Input/Output	SA1 External I/O Address IA3	
22	PB6	Input/Output	/SCS External I/O Address IA4		
23	PB7	Input/Output	/SLAVATN External I/O Address IA5		

Table 2. RCM4510W Pinout Configurations (continued)

Pin	Pin Name	Default Use	Alternate Use	Notes	
Header J1	24	PC0	Input/Output	TXD I/O Strobe I0 Timer C0 TCLKF	Serial Port D
	25	PC1	Input/Output	RXD/TXD I/O Strobe I1 Timer C1 RCLKF Input Capture	
	26	PC2	Input/Output	TXC/TXF I/O Strobe I2 Timer C2	Serial Port C
	27	PC3	Input/Output	RXC/TXC/RXF I/O Strobe I3 Timer C3 SCLKD Input Capture	
	28	PC4	Input/Output	TXB I/O Strobe I4 PWM0 TCLKE	Serial Port B (shared by XBee RF module)
	29	PC5	Input/Output	RXB/TXB I/O Strobe I5 PWM1 RCLKE Input Capture	
	30	PC6	Input/Output	TXA/TXE I/O Strobe I6 PWM2	Programming port
	31	PC7	Input/Output	RXA/TXA/RXE I/O Strobe I7 PWM3 SCLKC Input Capture	
	32	PE0	Input/Output	I/O Strobe I0 A20 Timer C0 TCLKF INT0 QRD1B	

Table 2. RCM4510W Pinout Configurations (continued)

Pin	Pin Name	Default Use	Alternate Use	Notes	
Header J1	33	PE1	Input/Output	I/O Strobe I1 A21 Timer C1 RXD/RCLKF INT1 QRD1A Input Capture	
	34	PE2	Input/Output	I/O Strobe I2 A22 Timer C2 TXF DREQ0 QRD2B	
	35	PE3	Input/Output	I/O Strobe I3 A23 Timer C3 RXC/RXF/SCLKD DREQ1 QRD2A Input Capture	
	36	PE4	Input/Output	I/O Strobe I4 /A0 INT0 PWM0 TCLKE	
	37	PE5/SMODE0	Input/Output	I/O Strobe I5 INT1 PWM1 RXB/RCLKE Input Capture	PE5 is the default configuration
	38	PE6/SMODE1	Input/Output	I/O Strobe I6 PWM2 TXE DREQ0	PE6 is the default configuration
	39	PE7/STATUS	Input/Output	I/O Strobe I7 PWM3 RXA/RXE/SCLKC DREQ1 Input Capture	PE7 is the default configuration

Table 2. RCM4510W Pinout Configurations (continued)

Pin	Pin Name	Default Use	Alternate Use	Notes	
Header J1	40	PD0	Input/Output	I/O Strobe I0 Timer C0 D8 INT0 SCLKD/TCLKF QRD1B	RCM4510W only
	41	PD1	Input/Output	IA6 I/O Strobe I1 Timer C1 D9 INT1 RXD/RCLKF QRD1A Input Capture	
	42	PD2	Input/Output	I/O Strobe I2 Timer C2 D10 DREQ0 TXF/SCLKC QRD2B	
	43	PD3	Input/Output	IA7 I/O Strobe I3 Timer C3 D11 DREQ1 RXC/RXF QRD2A Input Capture	
	44	PD4	Input/Output	I/O Strobe I4 D12 PWM0 TXB/TCLKE	
	45	PD5	Input/Output	IA6 I/O Strobe I5 D13 PWM1 RXB/RCLKE Input Capture	

Table 2. RCM4510W Pinout Configurations (continued)

Pin	Pin Name	Default Use	Alternate Use	Notes	
Header J1	46	PD6	Input/Output	I/O Strobe I6 D14 PWM2 TXA/TXE	Serial Port E (RCM4510W only)
	47	PD7	Input/Output	IA7 I/O Strobe I7 D15 PWM3 RXA/RXE Input Capture	
	48	CONVERT	Analog Input		Reserved for future use
	49	VREF	Analog reference voltage		
	50	GND	Ground		Ground
Header J4	1	ADC0/DIO0	Input/Output	Analog Input	Software-selectable
	2	ADC1/DIO1	Input/Output	Analog Input	Software-selectable
	3	ADC2/DIO2	Input/Output	Analog Input	Software-selectable
	4	ADC3/DIO3	Input/Output	Analog Input	Software-selectable
	5	GND	Ground		
	6	GPIO8/VREF	Input/Output	Analog reference voltage (1.2 V)	Software-selectable, analog ref. voltage not presently supported
	7	n.c.			
	8	+3.3 V			
	9	SYS_PWR_ON	Output		Used by XBee RF module to place or remove remaining RCM4510W circuitry in “sleep” mode
	10	GPIO0	Input/Output		
	11	GPIO13	Input/Output		
	12	n.c.			
	13	GPIO15	Input/Output		
	14	GPIO16	Input/Output		

4.1.1 Memory I/O Interface

The Rabbit 4000 address lines (A0–A19) and all the data lines (D0–D7) are routed internally to the onboard flash memory and SRAM chips. I/O write (/IOWR) and I/O read (/IORD) are available for interfacing to external devices, and are also used by the RCM4510W.

Parallel Port A can also be used as an external I/O data bus to isolate external I/O from the main data bus. Parallel Port B pins PB2–PB7 can also be used as an auxiliary address bus.

When using the external I/O bus for any reason, you must add the following line at the beginning of your program.

```
#define PORTA_AUX_IO // required to enable external I/O bus
```

Selected pins on Parallel Ports D and E as specified in Table 2 may be used for input capture, quadrature decoder, DMA, and pulse-width modulator purposes.

4.1.2 Other Inputs and Outputs

The STATUS and the two SMODE pins, SMODE0 and SMODE1, can be brought out to header J1 instead of the PE5–PE7 pins as explained in Appendix A.6.

/RESET_IN is normally associated with the programming port, but may be used as an external input to reset the Rabbit 4000 microprocessor and the RCM4510W memory.

/RESET_OUT is an output from the reset circuitry that can be used to reset other peripheral devices.

4.1.3 Auxiliary I/O

Up to nine additional digital I/O, up to four of which may be configured in software as analog inputs, a +3.3 V DC power supply point and ground, and a SYS_PWR_ON line are brought out on auxiliary I/O header J4. Section 4.4 describes the use of these lines in more detail.

4.2 Serial Communication

The RCM4510W module does not have any serial driver or receiver chips directly on the board. However, a serial interface may be incorporated on the board the RCM4510W is mounted on. For example, the Prototyping Board has an RS-232 transceiver chip.

4.2.1 Serial Ports

There are six serial ports designated as Serial Ports A, B, C, D, E, and F. All six serial ports can operate in an asynchronous mode up to the baud rate of the system clock divided by 8. An asynchronous port can handle 7 or 8 data bits. A 9th bit address scheme, where an additional bit is sent to mark the first byte of a message, is also supported.

Serial Port A is normally used as a programming port, but may be used either as an asynchronous or as a clocked serial port once application development has been completed and the RCM4510W is operating in the Run Mode.

Serial Port B is shared with the RCM4510W module's asynchronous XBee RF module. Flow control for the XBee RF module is provided from the Rabbit 4000 RxD+ and TxD– Ethernet pins.

Serial Ports C and D can also be operated in the clocked serial mode. In this mode, a clock line synchronously clocks the data in or out. Either of the two communicating devices can supply the clock. Note that PD2 and PD0 provide the SCLKC and SCLKD outputs automatically when Serial Ports C and D are set up as clocked serial ports.

Serial Ports E and F can also be configured as SDLC/HDLC serial ports. The IrDA protocol is also supported in SDLC format by these two ports. Serial Ports E and F must be configured before they can be used. The sample program `IOCONFIG_SWITCHCHO.C` in the Dynamic C `SAMPLES\RCM4500W\SERIAL` folder shows how to configure Serial Ports E and F.

Table 3 summarizes the possible parallel port pins for the serial ports and their clocks.

Table 3. Rabbit 4000 Serial Port and Clock Pins

Serial Port A	TXA	PC6, PC7, PD6	Serial Port E	TXE	PD6, PE6, PC6
	RXA	PC7, PD7, PE7		RXE	PD7, PE7, PC7
	SCLKA	PB1		RCLKE	PD5, PE5, PC5
Serial Port B	TXB	PC4, PC5, PD4	Serial Port F	TCLKE	PD4, PE4, PC4
	RXB	PC5, PD5, PE5		TXF	PD2, PE2, PC2
	SCLKB	PB0		RXF	PD3, PE3, PC3
Serial Port C	TXC	PC2, PC3	Serial Port F	RCLKF	PD1, PE1, PC1
	RXC	PC3, PD3, PE3		TCLKF	PD0, PE0, PC0
	SCLKC	PD2, PE2, PE7, PC7			
Serial Port D	TXD	PC0, PC1	RCLKE and RCLKF must be selected to be on the same parallel port as TXE and TXF respectively.		
	RXD	PC1, PD1, PE1			
	SCLKD	PD0, PE0, PE3, PC3			

4.2.1.1 Using the Serial Ports

The receive lines on the RCM4510W serial ports do not have pull-up resistors. If you are using the serial ports without a receiver chip (for example, for RS-422, RS-232, or RS-485 serial communication), the absence of a pull-up resistor on the receive line will likely lead to line breaks being generated since line breaks are normally generated whenever the receive line is pulled low. If you are operating a serial port asynchronously, you can inhibit character assembly during breaks by setting bit 1 in the corresponding Serial Port Extended Register to 1. Should you need line breaks, you will have to either add a pull-up resistor on your motherboard or use a receiver that incorporates the circuits to have the output default to the nonbreak levels.

The Dynamic C `RS232.LIB` library requires you to define the macro `RS232_NOCHARASSYINBRK` to inhibit break-character assembly for all the serial ports.

```
#define RS232_NOCHARASSYINBRK
```

This macro is already defined so that it is the default behavior for the sample programs in the Dynamic C `SAMPLES\RCM4500W\SERIAL` folder.

4.2.2 Programming Port

The RCM4510W is programmed via the 10-pin header labeled J2. The programming port uses the Rabbit 4000's Serial Port A for communication. Dynamic C uses the programming port to download and debug programs.

Serial Port A is also used for the following operations.

- Cold-boot the Rabbit 4000 on the RCM4510W after a reset.
- Fast copy designated portions of flash memory from one Rabbit-based board (the master) to another (the slave) using the Rabbit Cloning Board.

Alternate Uses of the Programming Port

All three Serial Port A signals are available as

- a synchronous serial port
- an asynchronous serial port, with the clock line usable as a general CMOS I/O pin

The programming port may also be used as a serial port via the **DIAG** connector on the programming cable.

In addition to Serial Port A, the Rabbit 4000 startup-mode (SMODE0, SMODE1), STATUS, and reset pins are available on the programming port.

The two startup-mode pins determine what happens after a reset—the Rabbit 4000 is either cold-booted or the program begins executing at address 0x0000.

The status pin is used by Dynamic C to determine whether a Rabbit microprocessor is present. The status output has three different programmable functions:

1. It can be driven low on the first op code fetch cycle.
2. It can be driven low during an interrupt acknowledge cycle.
3. It can also serve as a general-purpose output once a program has been downloaded and is running.

The reset pin is an external input that is used to reset the Rabbit 4000.

Refer to the *Rabbit 4000 Microprocessor User's Manual* for more information.

4.3 Programming Cable

The programming cable is used to connect the programming port of the RCM4510W to a PC serial COM port. The programming cable converts the RS-232 voltage levels used by the PC serial port to the CMOS voltage levels used by the Rabbit 4000.

When the **PROG** connector on the programming cable is connected to the RCM4510W programming port, programs can be downloaded and debugged over the serial interface.

The **DIAG** connector of the programming cable may be used on header J2 of the RCM4510W with the RCM4510W operating in the Run Mode. This allows the programming port to be used as a regular serial port.

4.3.1 Changing Between Program Mode and Run Mode

The RCM4510W is automatically in Program Mode when the **PROG** connector on the programming cable is attached, and is automatically in Run Mode when no programming cable is attached. When the Rabbit 4000 is reset, the operating mode is determined by the status of the SMODE pins. When the programming cable's **PROG** connector is attached, the SMODE pins are pulled high, placing the Rabbit 4000 in the Program Mode. When the programming cable's **PROG** connector is not attached, the SMODE pins are pulled low, causing the Rabbit 4000 to operate in the Run Mode.

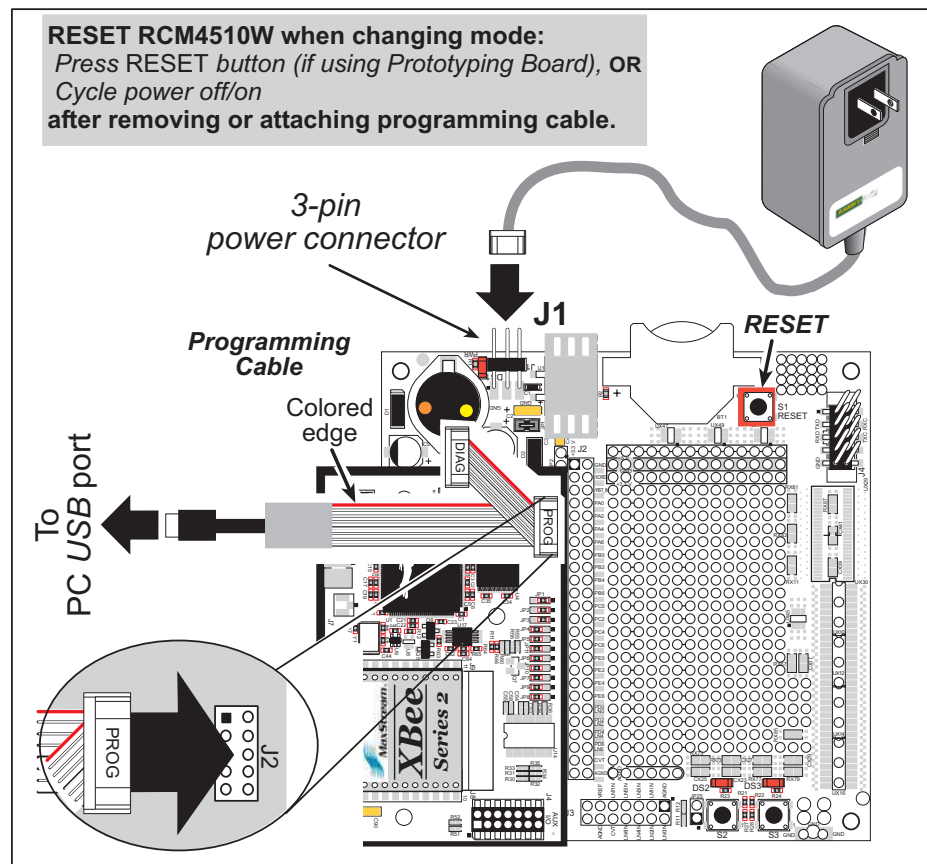

Figure 9. Switching Between Program Mode and Run Mode

A program “runs” in either mode, but can only be downloaded and debugged when the RCM4510W is in the Program Mode.

Refer to the *Rabbit 4000 Microprocessor User’s Manual* for more information on the programming port.

4.3.2 Standalone Operation of the RCM4510W

Once the RCM4510W has been programmed successfully, remove the programming cable from the programming connector and reset the RCM4510W. The RCM4510W may be reset by cycling, the power off/on or by pressing the **RESET** button on the Prototyping Board. The RCM4510W module may now be removed from the Prototyping Board for end-use installation.

CAUTION: Power to the Prototyping Board or other boards should be disconnected when removing or installing your RCM4510W module to protect against inadvertent shorts across the pins or damage to the RCM4510W if the pins are not plugged in correctly. Do not reapply power until you have verified that the RCM4510W module is plugged in correctly.

4.4 Auxiliary I/O

4.4.1 Digital I/O

The RCM4510W modules' XBee RF module has up to five general-purpose I/O on header J4 — GPIO0, GPIO8, GPIO13, GPIO15, and GPIO16. Table 4 provides the names used in Dynamic C for these pins and their default configurations.

Table 4. XBee RF Module GPIO Pin Setup

J4 Pin	Schematic Name	Dynamic C Name	Default Configuration
10	GPIO0	DIO_05	Digital Output (high)
6	GPIO8	DIO_12	Digital Input (pulled up)
11	GPIO13	DIO_04	Digital Output (high)
13	GPIO15	DIO_10	Digital Output (high)
14	GPIO16	DIO_11	Digital Input (pulled up)

All the pins have the following software-configurable features.

- Selectable as input or output.
- Output is either sinking or sourcing, and may be set up for a default high or low.
- Can be pulled up internally.

The four digital I/O, DIO0–DIO3, are similar to the general-purpose I/O, but may instead be configured in software as analog inputs.

NOTE: The XBee firmware associated with Dynamic C v. 10.46 does not support I/O reads for RCM4510W RabbitCore modules set up as API coordinators or as API routers.

The input switching threshold between logic 0 and logic 1 is 0.66–2.64 V DC, and the output switching threshold between logic 0 and logic 1 is 0.59–2.71 V DC.

4.4.2 A/D Converter

The RCM4510W modules' XBee RF module has four inputs on header J4 that may be set up in software as analog inputs.

The four analog input pins, ADC0–ADC3, each have an input impedance of 6–7 M Ω , depending on whether they are used as single-ended or differential inputs. The input signal can range from -1.2 V to +1.2 V (differential mode) or from 0 V to +1.2 V (single-ended mode).

Use a resistor divider such as the one shown in Figure 10 to measure voltages above 1.2 V on the analog inputs.

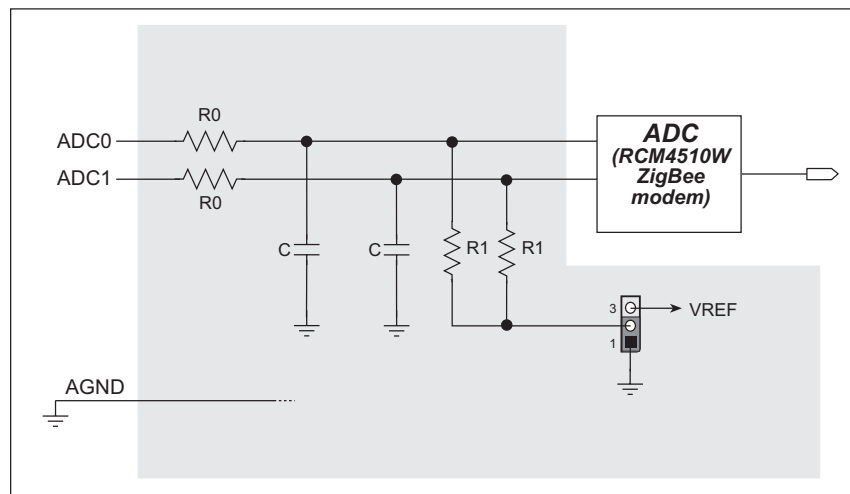

Figure 10. Resistor Divider Network for Analog Inputs

The R1 resistors are typically 20 k Ω to 100 k Ω , with a lower resistance leading to more accuracy, but at the expense of a higher current draw. The R0 resistors would then be 180 k Ω to 900 k Ω for a 10:1 attenuator. The capacitor filters noise pulses on the A/D converter input.

The A/D converter can only accept positive voltages. With the R1 resistors connected to ground, your analog circuit is well-suited to perform positive A/D conversions. When the R1 resistors are tied to ground for differential measurements, both differential inputs must be referenced to analog ground, and ***both inputs must be positive with respect to analog ground.***

If a device such as a battery is connected across two channels for a differential measurement, and it is *not* referenced to analog ground, then the current from the device will flow through both sets of attenuator resistors without flowing back to analog ground as shown in Figure 11. This will generate a negative voltage at one of the inputs, ADC1, which will almost certainly lead to inaccurate A/D

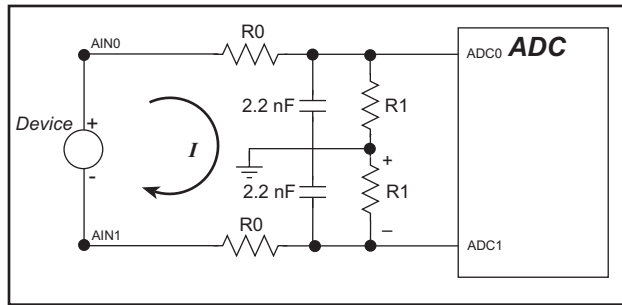

Figure 11. Current Flow from Ungrounded or Floating Source

conversions. To make such differential measurements, connect the R1 resistors to the A/D converter’s internal reference voltage, which is 1.2 V. This internal reference voltage can be configured in software to be available on pin 6 of header J4 as VREF, and allows you to convert analog input voltages that are negative with respect to analog ground.

NOTE: This software configuration option for VREF and differential measurements are not supported at this time.

NOTE: The amplifier inside the A/D converter’s internal voltage reference circuit has a very limited output-current capability. The internal buffer can source up to 20 mA and sink only up to 20 μ A. Use a separate buffer amplifier if you need to supply any load current.

4.4.3 Other Pin Features

There are two other features brought out on the auxiliary I/O header J4.

- There is a +3.3 V power supply point on pin 8, which can deliver up to 25 mA at 3.3 V DC. This power supply point is essentially a filtered and isolated version of the regulated +3.3 V DC power that is supplied to the RCM4510W RabbitCore module through pin 1 of header J1 from the motherboard.
- The SYS_PWR_ON signal on pin 9 is used by the XBee RF module to place the remaining circuitry on the RCM4510W RabbitCore module into a powered-down “sleep” mode or to bring it back up to normal operation.

4.5 Other Hardware

4.5.1 Clock Doubler

The clock doubler on the RCM4510W is disabled by default.

4.5.2 Spectrum Spreader

The Rabbit 4000 features a spectrum spreader, which helps to mitigate EMI problems. The spectrum spreader is on by default, but it may also be turned off or set to a stronger setting. The means for doing so is through a simple configuration macro as shown below.

1. Select the “Defines” tab from the Dynamic C **Options > Project Options** menu.
2. Normal spreading is the default, and usually no entry is needed. If you need to specify normal spreading, add the line

```
ENABLE_SPREADER=1
```

For strong spreading, add the line

```
ENABLE_SPREADER=2
```

To disable the spectrum spreader, add the line

```
ENABLE_SPREADER=0
```

NOTE: The strong spectrum-spreading setting is not recommended since it may limit the maximum clock speed or the maximum baud rate. It is unlikely that the strong setting will be used in a real application.

3. Click **OK** to save the macro. The spectrum spreader will be set according to the macro value whenever a program is compiled using this project file.

NOTE: Refer to the *Rabbit 4000 Microprocessor User’s Manual* for more information on the spectrum-spreading setting and the maximum clock speed.

4.6 Memory

4.6.1 SRAM

All RCM4510W modules have 512K of battery-backed data SRAM installed at U4.

4.6.2 Flash EPROM

All RCM4510W modules also have 512K of flash EPROM installed at U3.

NOTE: Rabbit recommends that any customer applications should not be constrained by the sector size of the flash EPROM since it may be necessary to change the sector size in the future.

Writing to arbitrary flash memory addresses at run time is discouraged. Instead, define a “user block” area to store persistent data. The functions **writeUserBlock** and **readUserBlock** are provided for this. Refer to the *Rabbit 4000 Microprocessor Designer’s Handbook* for additional information.

5. SOFTWARE REFERENCE

Dynamic C is an integrated development system for writing embedded software. It runs on an IBM-compatible PC and is designed for use with single-board computers and other devices based on the Rabbit microprocessor. Chapter 5 describes the libraries and function calls related to the RCM4510W.

5.1 More About Dynamic C

Dynamic C has been in use worldwide since 1989. It is specially designed for programming embedded systems, and features quick compile and interactive debugging. A complete reference guide to Dynamic C is contained in the *Dynamic C User's Manual*.

You have a choice of doing your software development in the flash memory or in the static SRAM included on the RCM4510W. The flash memory and SRAM options are selected with the **Options > Program Options > Compiler** menu.

The advantage of working in RAM is to save wear on the flash memory, which is limited to about 100,000 write cycles. The disadvantage is that the code and data might not both fit in RAM.

NOTE: Do not depend on the flash memory sector size or type in your program logic. The RCM4510W and Dynamic C were designed to accommodate flash devices with various sector sizes in response to the volatility of the flash-memory market.

Developing software with Dynamic C is simple. Users can write, compile, and test C and assembly code without leaving the Dynamic C development environment. Debugging occurs while the application runs on the target. Alternatively, users can compile a program to an image file for later loading. Dynamic C runs on PCs under Windows NT and later—see Rabbit's Technical Note TN257, *Running Dynamic C[®] With Windows Vista[®]*, for additional information if you are using a Dynamic C under Windows Vista. Programs can be downloaded at baud rates of up to 460,800 bps after the program compiles.

Dynamic C has a number of standard features.

- Full-feature source and/or assembly-level debugger, no in-circuit emulator required.
- Royalty-free TCP/IP stack with source code and most common protocols.
- Hundreds of functions in source-code libraries and sample programs:
 - ▶ Exceptionally fast support for floating-point arithmetic and transcendental functions.
 - ▶ RS-232 and RS-485 serial communication.
 - ▶ Analog and digital I/O drivers.
 - ▶ I²C, SPI, GPS, file system.
 - ▶ LCD display and keypad drivers.
- Powerful language extensions for cooperative or preemptive multitasking
- Loader utility program to load binary images into Rabbit targets in the absence of Dynamic C.
- Provision for customers to create their own source code libraries and augment on-line help by creating “function description” block comments using a special format for library functions.
- Standard debugging features:
 - ▶ Breakpoints—Set breakpoints that can disable interrupts.
 - ▶ Single-stepping—Step into or over functions at a source or machine code level, μ C/OS-II aware.
 - ▶ Code disassembly—The disassembly window displays addresses, opcodes, mnemonics, and machine cycle times. Switch between debugging at machine-code level and source-code level by simply opening or closing the disassembly window.
 - ▶ Watch expressions—Watch expressions are compiled when defined, so complex expressions including function calls may be placed into watch expressions. Watch expressions can be updated with or without stopping program execution.
 - ▶ Register window—All processor registers and flags are displayed. The contents of general registers may be modified in the window by the user.
 - ▶ Stack window—shows the contents of the top of the stack.
 - ▶ Hex memory dump—displays the contents of memory at any address.
 - ▶ **STDIO** window—`printf` outputs to this window and keyboard input on the host PC can be detected for debugging purposes. `printf` output may also be sent to a serial port or file.

5.2 Dynamic C Function Calls

5.2.1 Digital I/O

The RCM4510W was designed to interface with other systems, and so there are no drivers written specifically for the Rabbit 4000 I/O. The general Dynamic C read and write functions allow you to customize the parallel I/O to meet your specific needs. For example, use

```
WrPortI(PEDDR, &PEDDRShadow, 0x00);
```

to set all the Port E bits as inputs, or use

```
WrPortI(PEDDR, &PEDDRShadow, 0xFF);
```

to set all the Port E bits as outputs.

When using the external I/O bus on the Rabbit 4000 chip, add the line

```
#define PORTA_AUX_IO // required to enable external I/O bus
```

to the beginning of any programs using the external I/O bus.

The sample programs in the Dynamic C **SAMPLES/RCM4500W** folder provide further examples.

5.2.2 Serial Communication Drivers

Library files included with Dynamic C provide a full range of serial communications support. The **RS232.LIB** library provides a set of circular-buffer-based serial functions. The **PACKET.LIB** library provides packet-based serial functions where packets can be delimited by the 9th bit, by transmission gaps, or with user-defined special characters. Both libraries provide blocking functions, which do not return until they are finished transmitting or receiving, and nonblocking functions, which must be called repeatedly until they are finished, allowing other functions to be performed between calls. For more information, see the *Dynamic C Function Reference Manual* and Technical Note TN213, *Rabbit Serial Port Software*.

5.2.3 User Block

Certain function calls involve reading and storing calibration constants from/to the simulated EEPROM in flash memory located at the top 2K of the reserved user block memory area (3800–39FF). This leaves the address range 0–37FF in the user block available for your application.

These address ranges may change in the future in response to the volatility in the flash memory market, in particular sector size. The sample program **USERBLOCK_INFO.C** in the Dynamic C **SAMPLES\USERBLOCK** folder can be used to determine the version of the ID block, the size of the ID and user blocks, whether or not the ID/user blocks are mirrored, the total amount of flash memory used by the ID and user blocks, and the area of the user block available for your application.

The **USERBLOCK_CLEAR.C** sample program shows you how to clear and write the contents of the user block that you are using in your application (the calibration constants in the reserved area and the ID block are protected).

5.2.4 SRAM Use

The RCM4510W module has a battery-backed data SRAM and a program-execution SRAM. Dynamic C provides the `protected` keyword to identify variables that are to be placed into the battery-backed SRAM. The compiler generates code that maintains two copies of each protected variable in the battery-backed SRAM. The compiler also generates a flag to indicate which copy of the protected variable is valid at the current time. This flag is also stored in the battery-backed SRAM. When a protected variable is updated, the “inactive” copy is modified, and is made “active” only when the update is 100% complete. This assures the integrity of the data in case a reset or a power failure occurs during the update process. At power-on the application program uses the active copy of the variable pointed to by its associated flag.

The sample code below shows how a protected variable is defined and how its value can be restored.

```
main() {
    protected int state1, state2, state3;
    ...
    _sysIsSoftReset();    // restore any protected variables
```

Additional information on `protected` variables is available in the *Dynamic C User's Manual*.

5.2.5 RCM4510W Cloning

The RCM4510W does not have a pull-up resistor on the PB1 (CLKA) line of the programming port. Because of this, the procedure to generate clones from the RCM4510W differs from that used for other RabbitCore modules and single-boards computers. You must set the `CL_FORCE_MASTER_MODE` macro to 1 in the Dynamic C `LIB\Rabbit4000\BIOSLIB\CLONECONFIG.LIB` library to use the RCM4510W as a master for cloning. An RCM4510W master will not run the application, and further debugging is not possible as long as the `CL_FORCE_MASTER_MODE` macro is set to 1. Any cloned RCM4510W modules will be “sterile,” meaning that they cannot be used as a master for cloning. To develop and debug an application on an RCM4510W, comment out the `CL_FORCE_MASTER_MODE` macro or set it to 0.

NOTE: Instead of defining this macro in your application, you may simply add the line `CL_FORCE_MASTER_MODE=1` under the Dynamic C **Options > Project Options** “Defines” tab, then click **OK**. When you recompile your program, this will have the same effect as setting the macro to 1 within the `CLONECONFIG.LIB` library.

See Technical Note TN207, *Rabbit Cloning Board*, for additional information on Rabbit's cloning board and how cloning is done.

5.2.5.1 Including Firmware Update in Cloned Application

If you include the firmware update in the master RCM4510W program, clone this program to an RCM4510W clone, and then let that program run on the clone, then the firmware update will fail unless you remove the cloning cable from the clone before the firmware update begins.

To avoid this failure, Rabbit recommends that you include code in the master program that is to be cloned to check the firmware version when the RCM4510W resets or boots up. The reset or boot-up will happen as a matter of course once the cloning cable is removed and the RCM4510W clone operates in the Run Mode for the first time. The firmware version can be checked by calling `xbee_init()` — if an error returns, the firmware update will happen successfully since the cloning cable is no longer attached, and if there is no error returned, the firmware is already up-to-date and the RCM4510W clone will reset or boot up normally.

5.2.6 ZigBee Drivers

The ZigBee drivers are located in the `LIB\Rabbit4000\XBee` folder. Complete information on these libraries and the ZigBee function calls is provided in Section 6.4.

5.2.7 Prototyping Board Function Calls

The function calls described in this section are for use with the Prototyping Board features. The source code is in the Dynamic C `LIB\Rabbit4000\RCM4xxx\RCM45xxW.LIB` library if you need to modify it for your own board design.

Other generic functions applicable to all devices based on Rabbit microprocessors are described in the *Dynamic C Function Reference Manual*.

5.2.7.1 Board Initialization

`brdInit`

```
void brdInit(void);
```

DESCRIPTION

Call this function at the beginning of your program. This function initializes Parallel Ports A through E for use with the Prototyping Board.

Summary of Initialization

1. I/O port pins are configured for Prototyping Board operation.
2. Unused configurable I/O are set as tied outputs.
3. RS-232 is not enabled.
4. LEDs are off.
5. The slave port is disabled.

RETURN VALUE

None.

5.2.7.2 Alerts

These function calls can be found in the Dynamic C LIB\Rabbit4000\RCM4xxx\
RCM4xxx.LIB library.

timedAlert

```
void timedAlert(unsigned long timeout);
```

DESCRIPTION

Polls the real-time clock until a timeout occurs. The RCM4510W will be in a low-power mode during this time. Once the timeout occurs, this function call will enable the normal power source.

PARAMETER

timeout the duration of the timeout in seconds

RETURN VALUE

None.

SEE ALSO

`brdInit`

digInAlert

```
void digInAlert(int dataport, int portbit, int value,  
                unsigned long timeout);
```

DESCRIPTION

Polls a digital input for a set value or until a timeout occurs. The RCM4510W will be in a low-power mode during this time. Once a timeout occurs or the correct byte is received, this function call will enable the normal power source and exit.

PARAMETERS

dataport the input port data register to poll (e.g., PADR)
portbit the input port bit (0–7) to poll
value the value of 0 or 1 to receive
timeout the duration of the timeout in seconds (enter 0 for no timeout)

RETURN VALUE

None.

5.2.8 Auxiliary I/O Pins Function Calls

The function calls described in this section are for use with the pins on the auxiliary I/O header at J4. The source code is in the Dynamic C `LIB\Rabbit4000\XBee\XBEE_API.LIB` library if you need to modify it for your own board design.

The sample programs in the Dynamic C `SAMPLES\XBee` folder illustrate the use of the function calls.

`zb_io_init`

```
int zb_io_init(void);
```

DESCRIPTION

Initializes the I/O on the XBee RF module. The default behavior for each pin is pre-defined, but may be overridden before the `#use XBEE_API.LIB` statement or by calling the appropriate macro.

J4 Pin	Dynamic C Name	Functionality	Default Configuration	State	Pull-Up Mask Bit
1	<code>DIO_00</code>	Analog Input or Digital I/O	Analog Input	Not Applicable	4
2	<code>DIO_01</code>	Analog Input or Digital I/O	Analog Input	Not Applicable	3
3	<code>DIO_02</code>	Analog Input or Digital I/O	Analog Input	Not Applicable	2
4	<code>DIO_03</code>	Analog Input or Digital I/O	Analog Input	Not Applicable	1
6	<code>DIO_12</code>	Digital I/O	Digital Input	Pulled Up 30 k Ω	10
10	<code>DIO_05</code>	Digital I/O	Digital Output	Default High	8
11	<code>DIO_04</code>	Digital I/O	Digital Output	Default High	0
13	<code>DIO_10</code>	Digital I/O	Digital Output	Default Low	11
14	<code>DIO_11</code>	Digital I/O	Digital Input	Pulled Up 30 k Ω	12

`zb_io_init (cont'd)`

The pins are configured as analog inputs or as digital I/O using the following macros as examples before `#use XBEE_API.LIB`.

```
#define DIO_00 XBEE_IO_CONF_ANAIN      // bit 4
#define DIO_01 XBEE_IO_CONF_ANAIN      // bit 3
#define DIO_02 XBEE_IO_CONF_ANAIN      // bit 2
#define DIO_03 XBEE_IO_CONF_ANAIN      // bit 1
#define DIO_12 XBEE_IO_CONF_DIGIN       // bit 10
#define DIO_05 XBEE_IO_CONF_DIGOUT_HIGH // bit 8
#define DIO_04 XBEE_IO_CONF_DIGOUT_HIGH // bit 0
#define DIO_10 XBEE_IO_CONF_DIGOUT_LOW  // bit 11
#define DIO_11 XBEE_IO_CONF_DIGIN       // bit 12
```

NOTE: The mask order is different than for `DIO_INPUTS`. While all pins can be configured as either inputs or outputs, only `DIO_00 – DIO_03` can be configured as analog inputs.

RETURN VALUE

0 — success.

≠0 — one of the error codes returned by `zb_API_ATCmdResponse()`

5.2.8.1 Digital I/O

zb_dio_in

```
int zb_dio_in(int dio);
```

DESCRIPTION

Reads the logic state of a pin configured as a digital input pin. This value corresponds to the `dio` number.

PARAMETERS

`dio` the Dynamic C digital input pin number (0 – `ZB_MAX_PIN`, valid values are 0–5, 10–12) set up in `zb_io_init()`.

NOTE: The pin number is not the same as the `DIO_xx` macros described in `zb_io_init()`, which are used to configure the function of the pin only.

RETURN VALUE

0 or 1 — logic state.

`-EINVAL` — error (pin not configured as a digital input).

zb_dio_out

```
int zb_dio_out(int dio, int value);
```

DESCRIPTION

Sets the digital output value.

PARAMETERS

`dio` the Dynamic C digital output pin number (0 – `ZB_MAX_PIN`, valid values are 0–5, 10–12) set up in `zb_io_init()`.

`value` the logic level (0 or 1) the pin is set to.

NOTE: The pin number is not the same as the `DIO_xx` macros described in `zb_io_init()`, which are used to configure the function of the pin only.

RETURN VALUE

0 — success.

`-EINVAL` — error (pin not configured as a digital output).

5.2.8.2 Analog Inputs

zb_adc_in

```
int zb_adc_in(int dio);
```

DESCRIPTION

Reads the analog input on the designated pin and return its 10-bit value. To convert the reading to millivolts perform the following calculation.

$$\text{AD (mV)} = (\text{ADIO reading} / 1023) \times 1200 \text{ mV}$$

PARAMETER

dio the Dynamic C analog input pin number (0–3) set up in **zb_io_init()**.

NOTE: The pin number is not the same as the **DIO_XX** macros described in **zb_io_init()**, which are used to configure the function of the pin only.

RETURN VALUE

0–1023 — valid data.

–**EINVAL** — error (pin not configured as an analog input).

5.3 Upgrading Dynamic C

Dynamic C patches that focus on bug fixes are available from time to time. Check the Web site www.rabbit.com/support/ for the latest patches, workarounds, and bug fixes.

5.3.1 Add-On Modules

Starting with Dynamic C version 10.40, Dynamic C includes the popular μ C/OS-II real-time operating system, point-to-point protocol (PPP), FAT file system, RabbitWeb, and other select libraries. Rabbit also offers for purchase the Rabbit Embedded Security Pack featuring the Secure Sockets Layer (SSL) and a specific Advanced Encryption Standard (AES) library.

In addition to the Web-based technical support included at no extra charge, a one-year telephone-based technical support subscription is also available for purchase.

Visit our Web site at www.rabbit.com for further information and complete documentation.

6. USING THE ZIGBEE FEATURES

6.1 Introduction to the ZigBee Protocol

The ZigBee PRO specification was ratified in April, 2007, and covers high-level communication protocols for small, low-power digital modems based on the IEEE 802.15.4 standard for wireless personal area networks (WPANs). The XBee RF module used by the RCM4510W operates in the 2.4 GHz industrial, scientific, and medical (ISM) radio band in most jurisdictions worldwide.

The ZigBee protocol is ideal for embedded-system applications that are characterized by low data rates and low power consumption. A network of devices using the ZigBee protocol works via a self-organizing mesh network that can be used for industrial control, embedded sensors, data collection, smoke and intruder warning, and building automation. The power consumption of the individual device could be met for a year or longer using the originally installed battery.

A ZigBee device can be set up in one of three ways.

- As a *coordinator*: The coordinator serves as the root of the network tree. Each network can only have one coordinator. The coordinator stores information about the network and provides the repository for security keys.
- As a *router*: Routers pass data from other devices.
- As an *end device*: End devices contain just enough functionality to talk to their parent node (either the coordinator or a router), and cannot relay data from other devices.

The XBee RF module used by the RCM4510W (ZB) supports using the RCM4510W RabbitCore module in a mesh network. RCM4510W modules are preconfigured with ZNet 2.5 or ZB router firmware — only ZB firmware supports a mesh network. Coordinator and end-device firmware is included in the Dynamic C installation along with a sample program to allow you to download the firmware.

The firmware used with the XBee RF modules on the RCM4510W modules is based on the API command set.

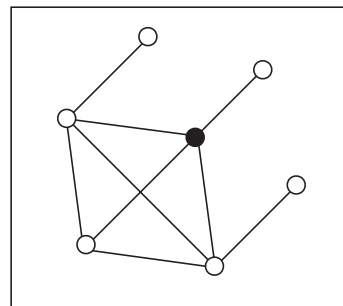

Figure 12. Mesh Network

An Introduction to ZigBee provides background information on the ZigBee protocol, and is available on the CD and on our [Web site](#).

6.1.1 ZNet vs. ZB Firmware

RCM4510W modules are preconfigured with ZNet 2.5 or ZB router firmware. The firmware preloaded at the factory is indicated with the model number and is reflected in different part numbers (see Table 1). Older RCM4510W modules shipped with ZNet firmware and do not have a sticker on their XBee RF module.

RCM4510W (ZNet)

RCM4510W (ZB)

- ZNet 2.5 firmware is supported by Dynamic C v. 10.21 and later versions. (Preview versions of the RCM4510W will work with Dynamic C v. 10.11 and later.)
- ZB firmware is supported by Dynamic C v. 10.46 and later versions.

ZigBee networks developed around the two types of firmware are essentially different networks that are not compatible with each other. It is possible to migrate an application developed with ZNet 2.5 firmware to ZB firmware by installing the ZB firmware on the XBee RF module and recompiling the application using Dynamic C v. 10.46 or later versions.

Some macros prior to Dynamic C v. 10.46 have been deprecated, but will still function with Dynamic C v. 10.46 or later versions. You can expect to see warning messages in this case. The only way to avoid this situation is to disable warning messages (not recommended), or to replace the macros with the new ones. The table below lists some of the commonly used macros.

Original Macro	New Macro
ZIGBEE_COORDINATOR	XBEE_ROLE NODE_TYPE_COORD
ZIGBEE_ROUTER	XBEE_ROLE NODE_TYPE_ROUTER
ZIGBEE_ENDDEV	XBEE_ROLE NODE_TYPE_ENDDEV

See Section 6.2.2 for additional information on macros that are specific to the two types of firmware.

6.2 ZigBee Sample Programs

In order to run the sample programs discussed in this chapter and elsewhere in this manual,

1. Your module must be plugged into the Prototyping Board as described in Chapter 2, “Getting Started.”
2. Dynamic C must be installed and running on your PC.
3. The programming cable must connect the programming header on the RCM4510W to your PC.
4. Power must be applied to the module through the Prototyping Board.
5. The Digi® XBee USB used as the ZigBee coordinator must be connected to an available USB port on your PC if you are exercising the ZigBee protocol, or you need a second RCM4510W module if so instructed.

Refer to Chapter 2, “Getting Started,” if you need further information on these steps.

To run a sample program, open it with the **File** menu (if it is not still open), then compile and run it by pressing **F9**.

Each sample program has comments that describe the purpose and function of the program. Follow the instructions at the beginning of the sample program.

The sample programs in the Dynamic C `SAMPLES\RCM4500W\XBee` and `SAMPLES\XBee` folders illustrate the use of the XBee function calls.

6.2.1 Setting Up the Digi XBee USB Coordinator

1. Connect the Digi® XBee USB acting as a ZigBee coordinator to an available USB port on your PC or workstation. Your PC should recognize the new USB hardware.
2. Compile and run the `XBEE_GPIO_SERVER.C` sample program in the Dynamic C `SAMPLES\RCM4500W\XBee` folder.
3. Open the ZigBee Utility by double-clicking `XBEE_GPIO_GUI.exe` in the Dynamic C `Utilities\XBee GPIO GUI` folder — if you have problems launching the ZigBee Utility, install a .Net Framework by double-clicking `dotnetfx.exe` in the Dynamic C `Utilities\dotnetfx` folder. You may add a shortcut to the ZigBee Utility on your desktop.
4. Confirm the following hardware setup is displayed on the “PC Settings” tab.

- 115200 baud
- Hardware flow control
- 8 data bits
- No parity
- 1 stop bit

Now select the COM port the Digi® XBee USB is connected to, and click the “Open Com Port” button. The message “Radio Found” is displayed to indicate that you selected the correct COM port. The ZigBee parameters (firmware version, operating channel, PAN ID) for the Digi® XBee USB will be displayed in the “Radio Parameters” box. Go to **Control Panel > System > Hardware > Device Manager > Ports** on your PC if you need help in identifying the USB COM port.

- Any ZigBee devices discovered will be displayed in the “Devices Discovered” window to the right.

If the utility times out and no ZigBee devices are displayed, you will have to reconfigure the Digi® XBee USB and recompile the sample program once you make sure the RCM4510W is powered up. The timeout may occur if you are doing development simultaneously with more than one ZigBee coordinator. Appendix D explains the steps to reconfigure the Digi® XBee USB.

- Select a device with your mouse pointer and click on the selected device to select that device. This device will now be displayed in the “Selected Device” area.

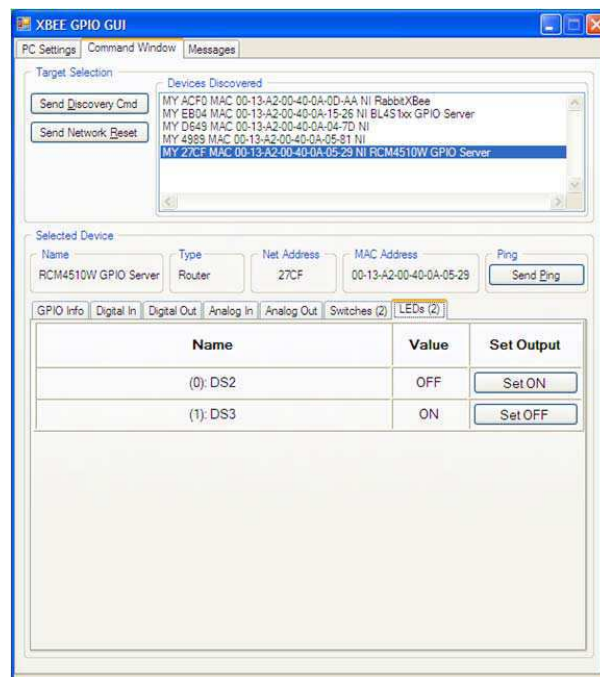

- You are now ready to interface with the RCM4510W via the ZigBee protocol. Try pinging the selected device by clicking the “Send Ping” button.

6.2.2 Setting up Sample Programs

The sample programs are set up so that the RCM4510W module you are using is a ZigBee end device, router, or coordinator. Uncomment the line corresponding to the role the RCM4510W will have once it is running the sample program. The default described in the sample programs is for the RCM4510W module to be either a router (shown below) or an end device.

```
// Set XBEE_ROLE to NODE_TYPE_COORD, NODE_TYPE_ROUTER or NODE_TYPE_ENDDEV
// to match your XBee's firmware.
#define XBEE_ROLE    NODE_TYPE_ROUTER
```

NOTE: Remember that the firmware loaded to the XBee RF module is different depending on whether the RCM4510 W is an end device/router (default) or a coordinator. See Appendix D, “Additional Configuration Instructions,” for information on how to download firmware to the RCM4510W module to set it up as a coordinator or to resume its original configuration as a router (ZigBee PRO) or an end device/router (ZNet 2.5).

There are several macros that may be changed to facilitate your setup. The macros can be included as part of the program code, or they may be put into the Program Options “Defines” on the “Defines” tab in the **Options > Program Options** menu.

ZB	ZNet 2.5
<p><i>Extended PAN ID</i> — the 64-bit network ID. Defaults to DEFAULT_PANID if set in the Dynamic C <code>LIB\Rabbit4000\XBee\XBEE_API.LIB</code> library, otherwise defaults to <code>0x0123456789abcdef</code> to match the default used on the Digi® XBee USB.</p> <p>If set to <code>0x00</code>, tells coordinators to “select a random extended PAN ID,” and tells routers and end devices to “join any network.”</p> <p>Change the extended PAN ID if you are developing simultaneously with more than one ZigBee coordinator.</p> <pre>#define DEFAULT_EXTPANID "0x0123456789abcdef"</pre>	<p><i>PAN ID</i> — the network ID. Defaults to <code>0x0234</code> via the macro in the Dynamic C <code>LIB\Rabbit4000\XBee\XBEE_API.LIB</code> library. Change the PAN ID if you are developing simultaneously with more than one ZigBee coordinator.</p> <pre>#define DEFAULT_PANID 0x0234</pre>

Channel mask — defaults to `0x1FFE`, i.e., all 12 possible channels via the macro in the Dynamic C `LIB\Rabbit4000\XBee\XBEE_API.LIB` library. (Do not use bits 14 and 15 for compatibility with the XBee PRO.)

```
#define DEFAULT_CHANNELS XBEE_DEFAULT_CHANNELS
```

Node ID — the ID of your particular node via the macro in the Dynamic C **LIB\Rabbit4000\XBee\XBEE_API.LIB** library. Each node should have a unique identifier of up to 20 printable characters.

- Defaults to **RabbitXBee**.
- Can be set to a global variable, or to a function that returns a pointer to a static buffer.

```
#define NODEID_STR "RabbitXBee"
```

The XBee sample programs in the Dynamic C **SAMPLES\XBee** folder illustrate the use of AT commands with the XBee RF module.

- **AT_INTERACTIVE.C**—This sample program shows how to set up and use AT commands with the XBee RF module.

The program will print out a list of AT commands in the Dynamic C **STDIO** window. You may type in either “ATxx” or just the “xx” part of the command.

- Use just the AT command to read any of the values.
- Use [AT]xx yyyy (where the y is an integer up to 32 bits) to set any of the “set or read” values. (Note that this works for NI, the *node identifier*, where the data will be a Node ID.string in quotes — [AT]NI "Node ID string" where the quotes contain the string data).

Note that you can also use hex notation by prefixing the parameter with 0x and using an even number of hex characters.

- Type “menu” to redisplay the menu of commands.
 - Press **F4** to exit and close the **STDIO** window.
- **AT_RUNONCE.C**—This sample program uses many of the most important and useful AT commands. Several commands can either set a parameter or read it. This sample program simply reads the parameters and displays the results.

Compile and run this sample program. The program will display the results in the Dynamic C **STDIO** window.

The XBee sample programs in the Dynamic C **SAMPLES\RCM4500W\XBee** folder exercise the XBee function calls on the XBee RF module on the RCM4510W.

- **SLEEPMODE.C**—This sample program shows how to place the RCM4510W module in the “sleep” mode where most power is removed from the RCM4510W module. Power is restored once a message is received or after a specified time interval. This sample program demonstrates waking after a specified time interval.

Sleeping only works on end devices, so the **XBEE_ROLE** macro is set to **NODE_TYPE_ENDDEV** in this sample program. Because the XBee RF module turns the Rabbit processor off and on, a serial terminal emulator is required once the program has been compiled.

1. Compile and run the sample program on the RCM4510W module.
2. Once the sample program is running, choose “Close Connection” from the in Dynamic C **Run** menu, and unplug the AC adapter supply power to the Prototyping Board.
3. Connect the **DIAG** connector instead of the **PROG** connector on the programming cable to the RCM4510 programming header.
4. Open the serial port in your serial terminal emulator such as TeraTerm or Hyperterminal to connect to the serial port at 57600 baud.
5. Plug the AC adapter back in to apply power to the Prototyping Board once again.

Once the XBee RF module on the RCM4510W completes its initialization (it joins the network), you will be prompted to enter a “sleep” time in milliseconds — enter the number followed by the **Enter** key. There will be a delay of a few seconds before the RCM4510W module powers off. When the RCM4510W module powers back up, it will begin running this program again from the beginning.

NOTE: This sample program does not demonstrate the saving state. State information may be saved in battery-backed RAM before the RCM4510W module is placed in the sleep mode.

- **SLEEPMODE2.C**—This sample program shows how to place the RCM4510W module in the “sleep” mode where most power is removed from the RCM4510W module. Power is restored once a message is received or after a specified time interval. This sample program demonstrates waking after a specified time interval.

Sleeping only works on end devices, so the **XBEE_ROLE** macro is set to **NODE_TYPE_ENDDEV** in this sample program. Because the XBee RF module turns the Rabbit processor off and on, a serial terminal emulator is required once the program has been compiled.

1. Compile and run the sample program on the RCM4510W module.
2. Once the sample program is running, choose “Close Connection” from the in Dynamic C **Run** menu, and unplug the AC adapter supply power to the Prototyping Board.
3. Connect the **DIAG** connector instead of the **PROG** connector on the programming cable to the RCM4510 programming header.
4. Open the serial port in your serial terminal emulator such as TeraTerm or Hyperterminal to connect to the serial port at 57600 baud.
5. Plug the AC adapter back in to apply power to the Prototyping Board once again.

Once the XBee RF module on the RCM4510W completes its initialization (it joins the network), you will be prompted to enter three values that control the XBee RF module's sleep mode — enter the values followed by the **Enter** key each time. Once you have entered these values via the serial terminal emulator, press any key to initiate the sleep mode. There will be a delay of a few seconds before the RCM4510W module powers off. When the RCM4510W module powers back up, it will begin running this program again from the beginning.

NOTE: This sample program does not demonstrate the saving state. State information may be saved in battery-backed RAM before the RCM4510W module is placed in the sleep mode.

- **XBEE_GPIO_SERVER.C**—This sample program shows how to set up and use endpoints and clusters. It is meant to be run with the Windows GUI client (installed in Dynamic C's **Utilities** directory) and a Digi USB XBee coordinator or with the GPIO client sample program (**SAMPLES/XBEE/XBEE_GPIO_CLIENT.C**) running on an RCM4510W RabbitCore module or on a single-board computer with a separate XBee RF module.

Compile and run this sample program with the RCM4510W RabbitCore module installed on the Prototyping Board. Run the Windows GUI client (**XBEE_GPIO_GUI.exe** in the Dynamic C **Utilities\XBee GPIO GUI** folder) on your PC. Configure the GUI client to connect to the Digi USB XBee coordinator and scan for devices. Make sure the RCM4510W and the Digi USB XBee coordinator are configured with the same PAN ID or extended PAN ID.

If you run the **XBEE_GPIO_CLIENT.C** sample program on another board with an XBee RF module, set the PAN IDs to match between the client and the server sample programs.

Now select the GPIO server and use the GUI interface on the PC, or the command-line client on another XBee-equipped board to view the server's inputs and change its outputs. For example, you can toggle the LEDs on the Prototyping Board on/off.

6.3 Using the Sleep Mode

The RCM4510W RabbitCore module has two components that are involved when the sleep mode is invoked — the XBee RF module and the Rabbit 4000 microprocessor.

End devices, unlike coordinators and routers, can enter a low-power sleep mode. This sleep mode is controlled by the XBee RF module, and fully powers down the Rabbit 4000 microprocessor for significant savings in power use.

The sleep mode can only be initiated while the RCM4510W is in the Run Mode (see Section 4.3.1 for more information on the Program Mode and the Run Mode).

Once the XBee RF module on the RCM4510W is operating in the sleep mode, it will periodically wake up and poll its parent router or coordinator to determine whether there is an incoming message. If one is found, the message will be received and the Rabbit 4000 microprocessor will be restarted. Otherwise the XBee RF module will return to sleep. Depending on how the sleep mode is configured, the XBee RF module may also restart the Rabbit 4000 microprocessor after a timeout has passed even if no message is received.

The sleep mode is controlled by the XBee RF module with a set of user-configurable parameters. Although a parameter can be set with an AT command, the recommended procedure is to only initiate the sleep mode using either the `zb_Rabbit_poweroff()` or the `xb_sleep()` function call.

The most important parameters are ST, SP, and SN. Together they control the duration of sleep and wake times.

- ST is measured in milliseconds, and controls the amount of time the XBee RF module, and consequently the Rabbit microprocessor, will stay awake waiting for RF or serial data before going to sleep. If any data are received, the ST counter will be reset. The Rabbit 4000 microprocessor needs approximately two seconds to boot and reinitialize the XBee RF module, so the value of ST must be at least 2000.
- SP is measured in 0.01 second intervals and controls the length of sleep for the XBee RF module. The XBee RF module will operate in a low-power mode for the time specified in SP, and then wake up briefly to poll its parent for a message. Depending on the value of SN, the XBee RF module may then either return to sleep or wake up the Rabbit 4000 microprocessor. There are several important considerations for SP.
 - The ZigBee parent (coordinator or router) can buffer a message for only 30 seconds, so SP must be set to no more than 28 seconds.
 - While SP is measured in 0.01 second intervals, it only has a 0.25 second resolution, and any value sent to the XBee RF module is rounded automatically.
 - The overhead of polling for a message was tested internally and was found to be approximately 20 ms. Thus a hypothetical sleep with SN = 100 and SP = 100 will not wake the Rabbit microprocessor until 102 seconds have elapsed (rather than the expected 100 seconds). The polling time may be sensitive to network conditions and firmware version, so you should perform your own testing if timing is critical.
- SN determines how many multiples of SP the radio will sleep before waking up if no message was otherwise received.

Two additional parameters are described below for completeness.

- WH determines how long the XBee RF module will hold a message for the RCM4510W to receive. Like ST, this parameter must be set carefully to ensure no messages are lost at startup. It is currently set to 3 seconds.
- SO is a conditional flag and determines whether the XBee RF module will wake the Rabbit 4000 microprocessor if SN and SP expire, or whether both parameters are reset to resume the sleep mode immediately.

There are several important ramifications and interactions with the operation of other function calls to consider when using the sleep mode.

- When the Rabbit 4000 microprocessor wakes up from sleep, both the RCM4510W and user application will fully restart. The user program will not resume from the point at which it went to sleep.
- User data should be initialized prior to calling `xb_ee_init()` to ensure that cluster functions or the default message handler process an incoming wake message correctly.
- When sleep is initiated, both the XBee RF module and the Rabbit 4000 microprocessor will remain awake for the time in ST before actually powering down the Rabbit 4000 microprocessor and entering a low-power mode. Any messages received during this time period will cause the counter to reset, and must be processed immediately or be lost.
- An end device is always preparing to sleep. Use `xb_stayawake()` to set ST to its maximum value and periodically send data to the XBee RF module to keep it awake. Blocking for long periods of time and failing to call `xb_tick()` for more than 30 seconds could result in the RCM4510W going to sleep unexpectedly.

The `SLEEPMODE.C` and `SLEEPMODE2.C` sample programs in the Dynamic C `SAMPLES\RCM4500W\XBEE` folder and the function documentation for `zb_Rabbit_poweroff()` and `xb_sleep()` provide more specific information regarding the implementation and use of the sleep mode.

6.4 Dynamic C Function Calls

Function calls for use with the XBee RF modules are in the Dynamic C `LIB\Rabbit4000\XBee\XBEE_API.LIB` library. These ZigBee specific function calls are described in *An Introduction to ZigBee*, which is included in the online documentation set.

6.5 Where Do I Go From Here?

NOTE: If you purchased your RCM4510W through a distributor or through a Rabbit partner, contact the distributor or partner first for technical support.

If there are any problems at this point:

- Use the Dynamic C **Help** menu to get further assistance with Dynamic C.
- Check the Rabbit Technical Bulletin Board and forums at www.rabbit.com/support/bb/ and at www.rabbit.com/forums/.
- Use the Technical Support e-mail form at www.rabbit.com/support/.

If the sample programs ran fine, you are now ready to go on.

An Introduction to ZigBee provides background information on the ZigBee protocol, and is available on the CD and on our [Web site](#).

Digi's *XBee® OEM RF Modules* provides complete information for the XBee RF module used on the RCM4510W RabbitCore modules, provides background information on the ZigBee PRO protocol, and is available at ftp1.digi.com/support/documentation/90000976_a.pdf.



APPENDIX A. RCM4510W SPECIFICATIONS

Appendix A provides the specifications for the RCM4510W, and describes the conformal coating.

A.1 Electrical and Mechanical Characteristics

Figure A-1 shows the mechanical dimensions for the RCM4510W.

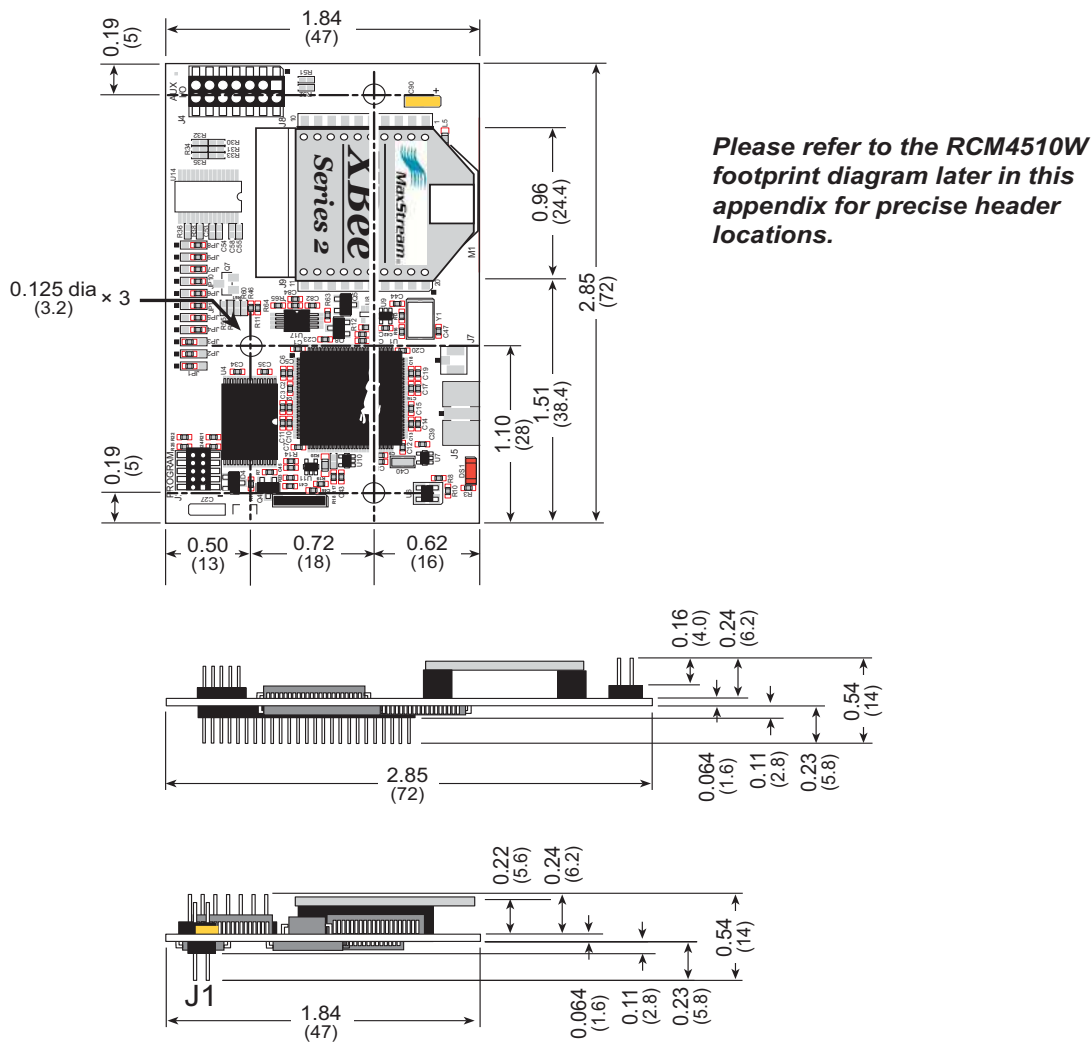

Figure A-1. RCM4510W Dimensions

NOTE: All measurements are in inches followed by millimeters enclosed in parentheses.
All dimensions have a manufacturing tolerance of ± 0.01 " (0.25 mm).

It is recommended that you allow for an “exclusion zone” of 0.04" (1 mm) around the RCM4510W in all directions when the RCM4510W is incorporated into an assembly that includes other printed circuit boards. An “exclusion zone” of 0.08" (2 mm) is recommended below the RCM4510W when the RCM4510W is plugged into another assembly. Figure A-2 shows this “exclusion zone.”

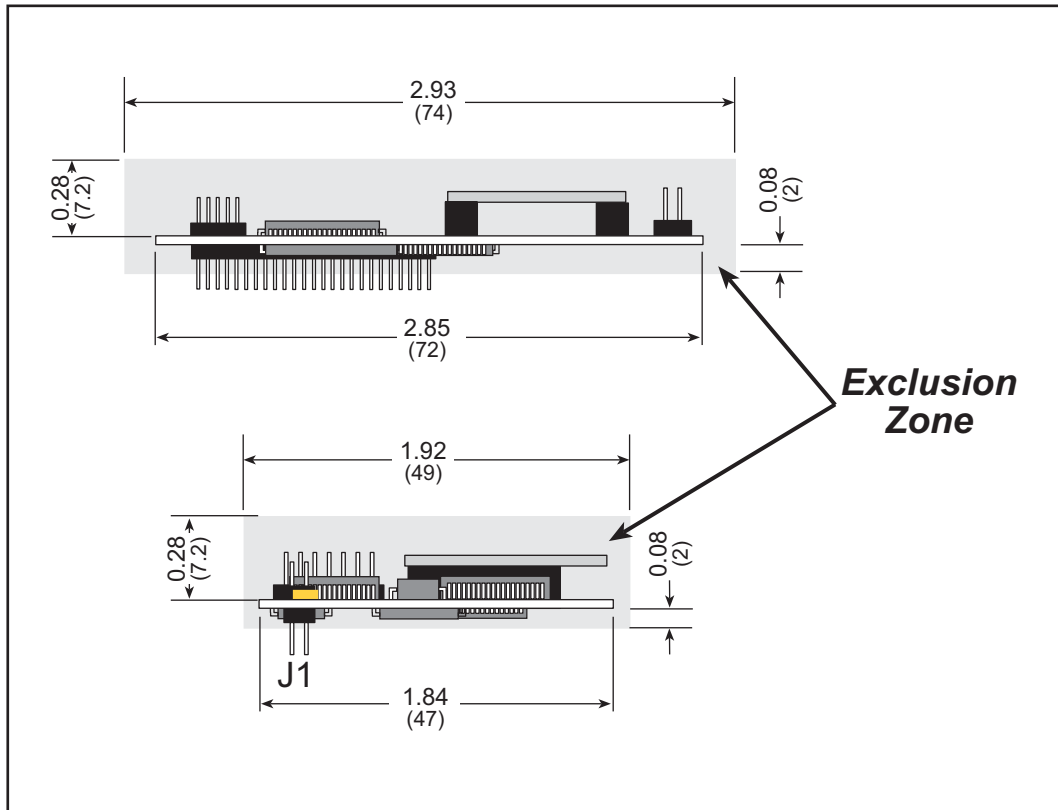

Figure A-2. RCM4510W “Exclusion Zone”

NOTE: There is an antenna associated with the RCM4510W RabbitCore modules. The antenna is on the XBee RF modules for the standard versions of the RCM4510W, and is on the printed circuit board near the shielded modem below header J4. Do not use any RF-absorbing materials in these vicinities in order to realize the maximum range.

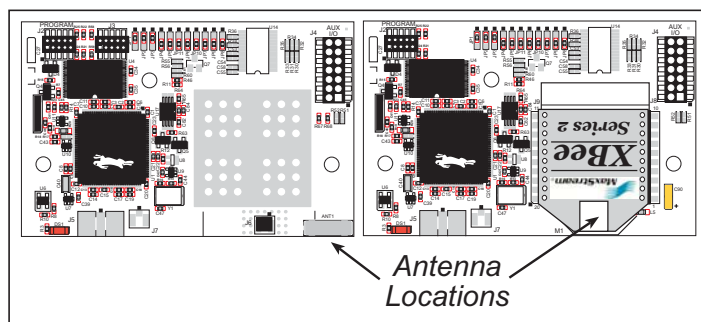

Table A-1 lists the electrical, mechanical, and environmental specifications for the RCM4510W.

Table A-1. RCM4510W Specifications

Parameter	RCM4510W
Microprocessor	Rabbit [®] 4000 at 29.49 MHz
Flash Memory	512K
Data SRAM	512K
Backup Battery	Connection for user-supplied backup battery (to support RTC and data SRAM)
General Purpose I/O	up to 49 parallel digital I/O lines: <ul style="list-style-type: none"> • up to 40 Rabbit 4000 pins configurable with four layers of alternate functions • up to 9 XBee RF module pins, four of which may be configured as analog inputs*
Additional Inputs	Startup mode (2), reset in
Additional Outputs	Status, reset out
Analog Inputs*	4 channels single-ended 0–1.2 V DC
<ul style="list-style-type: none"> • A/D Converter Resolution 	10 bits
<ul style="list-style-type: none"> • A/D Conversion Time (including raw count and Dynamic C) 	40 ms
External I/O Bus	Can be configured for 8 data lines and 6 address lines (shared with parallel I/O lines), plus I/O read/write
Serial Ports	6 high-speed, CMOS-compatible ports: <ul style="list-style-type: none"> • all 6 configurable as asynchronous (with IrDA), 4 as clocked serial (SPI), and 2 as SDLC/HDLC • 1 asynchronous clocked serial port shared with programming port
Serial Rate	Maximum asynchronous baud rate = CLK/8
Slave Interface	Slave port allows the RCM4510W to be used as an intelligent peripheral device slaved to a master processor
Real Time Clock	Yes
Timers	Ten 8-bit timers (6 cascadable from the first), one 10-bit timer with 2 match registers, and one 16-bit timer with 4 outputs and 8 set/reset registers
Watchdog/Supervisor	Yes

Table A-1. RCM4510W Specifications (continued)

Parameter	RCM4510W
Pulse-Width Modulators	4 channels synchronized PWM with 10-bit counter 4 channels variable-phase or synchronized PWM with 16-bit counter
Input Capture	2-channel input capture can be used to time input signals from various port pins
Quadrature Decoder	2-channel quadrature decoder accepts inputs from external incremental encoder modules
Power with ZigBee® Modem (pins unloaded)	3.3 V.DC ±5%
	150 mA @ 3.3 V while transmitting/receiving 80 mA @ 3.3 V while not transmitting/receiving <20 µA @ 3.3 V while asleep
Operating Temperature	-40°C to +85°C
Humidity	5% to 95%, noncondensing
Connectors	One 2 × 7, 2 mm pitch IDC signal header One 2 × 25, 1.27 mm pitch IDC signal header One 2 × 5, 1.27 mm pitch IDC programming header
Board Size with XBee RF module Installed	1.84" × 2.85" × 0.54" (47 mm × 72 mm × 14 mm)
XBee RF Module	
RF Module	Digi International XBee®
Compliance	802.15.4 standard (ZigBee compliant)

* These I/O pins from the XBee RF module are available on auxiliary I/O header J4.

A.1.1 XBee RF Module

Table A-2 shows the XBee RF module specifications.

Table A-2. XBee RF Module Specifications

Parameter		Specification
RF Module		Digi International XBee®
Compliance		802.15.4 standard (ZigBee compliant)
Frequency		ISM 2.4 GHz
Performance	Indoor Range	100 ft (30 m)
	Outdoor Line-of-Sight Range	300 ft (90 m)
	Transmit Power Output	1 mW (0 dBm)
	RF Data Rate	250,000 bps
	Receiver Sensitivity	-92 dBm (1% PER)
Antenna		Chip antenna
Supported Network Topologies		<ul style="list-style-type: none"> • Point-to-point • Point-to-multipoint • Peer-to-peer • Mesh
Number of RF Channels		16 direct-sequence channels
Filtration Options		<ul style="list-style-type: none"> • PAN ID • Channel • Source/destination addresses
Power (typical)	Transmit	40 mA @ 3.3 V DC ±5%
	Idle/Receive	40 mA @ 3.3 V DC ±5%

The XBee RF module that consists of discrete components on the preview versions of the RCM4510W module has the same specifications.

A.1.2 Headers

The RCM4510W uses a header at J1 for physical connection to other boards. J1 is a 2×25 SMT header with a 1.27 mm pin spacing. J2, the programming port, is a 2×5 header with a 1.27 mm pin spacing. Header J4 supplies auxiliary I/O supported by the XBee RF module, and is a 2×7 SMT header with a 2 mm pin spacing

Figure A-3 shows the layout of another board for the RCM4510W to be plugged into. These reference design values are relative to one of the mounting holes.

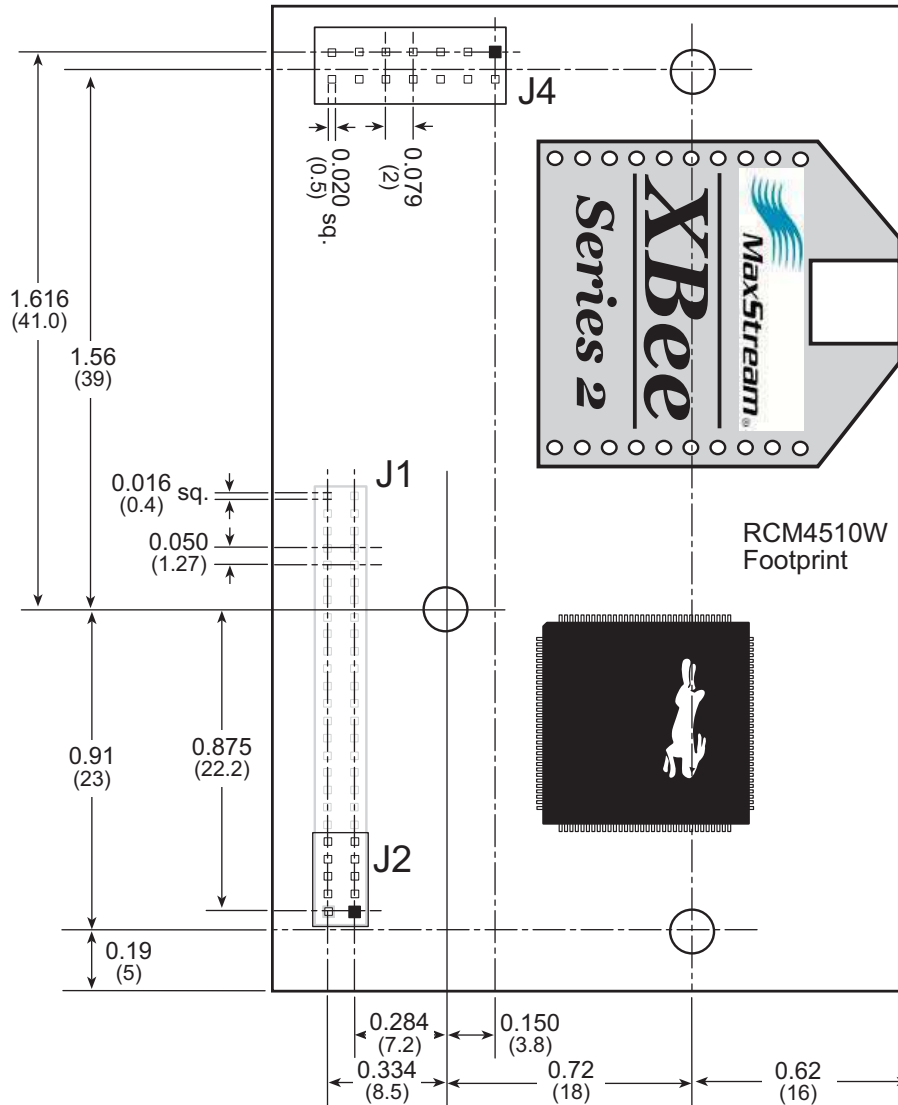

Figure A-3. User Board Footprint for RCM4510W

A.2 Rabbit 4000 DC Characteristics

Table A-3. Rabbit 4000 Absolute Maximum Ratings

Symbol	Parameter	Maximum Rating
T_A	Operating Temperature	-40° to +85°C
T_S	Storage Temperature	-55° to +125°C
V_{IH}	Maximum Input Voltage	$V_{DDIO} + 0.3\text{ V}$ (max. 3.6 V)
V_{DDIO}	Maximum Operating Voltage	3.6 V

Stresses beyond those listed in Table A-3 may cause permanent damage. The ratings are stress ratings only, and functional operation of the Rabbit 4000 chip at these or any other conditions beyond those indicated in this section is not implied. Exposure to the absolute maximum rating conditions for extended periods may affect the reliability of the Rabbit 4000 chip.

Table A-4 outlines the DC characteristics for the Rabbit 4000 at 3.3 V over the recommended operating temperature range from $T_A = -40^\circ\text{C}$ to $+85^\circ\text{C}$, $V_{DDIO} = 3.0\text{ V}$ to 3.6 V.

Table A-4. 3.3 Volt DC Characteristics

Symbol	Parameter	Min	Typ	Max
V_{DDIO}	I/O Ring Supply Voltage, 3.3 V	3.0 V	3.3 V	3.6 V
	I/O Ring Supply Voltage, 1.8 V	1.65 V	1.8 V	1.90 V
V_{IH}	High-Level Input Voltage ($V_{DDIO} = 3.3\text{ V}$)		2.0 V	
V_{IL}	Low-Level Input Voltage ($V_{DDIO} = 3.3\text{ V}$)		0.8 V	
V_{OH}	High-Level Output Voltage ($V_{DDIO} = 3.3\text{ V}$)		2.4 V	
V_{OL}	Low-Level Output Voltage ($V_{DDIO} = 3.3\text{ V}$)		0.4 V	
I_{IO}	I/O Ring Current @ 29.4912 MHz, 3.3 V, 25°C			12.2 mA
I_{DRIVE}	All other I/O (except TXD+, TXDD+, TXD-, TXDD-)			8 mA

A.3 I/O Buffer Sourcing and Sinking Limit

Unless otherwise specified, the Rabbit I/O buffers are capable of sourcing and sinking 8 mA of current per pin at full AC switching speed. Full AC switching assumes a 29.4 MHz CPU clock with the clock doubler enabled and capacitive loading on address and data lines of less than 70 pF per pin. The absolute maximum operating voltage on all I/O is 3.6 V.

A.4 Bus Loading

You must pay careful attention to bus loading when designing an interface to the RCM4510W. This section provides bus loading information for external devices.

Table A-5 lists the capacitance for the various RCM4510W I/O ports.

Table A-5. Capacitance of Rabbit 4000 I/O Ports

I/O Ports	Input Capacitance (pF)	Output Capacitance (pF)
Parallel Ports A to E	12	14

Table A-6 lists the external capacitive bus loading for the various RCM4510W output ports. Be sure to add the loads for the devices you are using in your custom system and verify that they do not exceed the values in Table A-6.

Table A-6. External Capacitive Bus Loading -40° C to +85°C

Output Port	Clock Speed (MHz)	Maximum External Capacitive Loading (pF)
All I/O lines with clock doubler enabled	29.49	100

Figure A-4 shows a typical timing diagram for the Rabbit 4000 microprocessor external I/O read and write cycles.

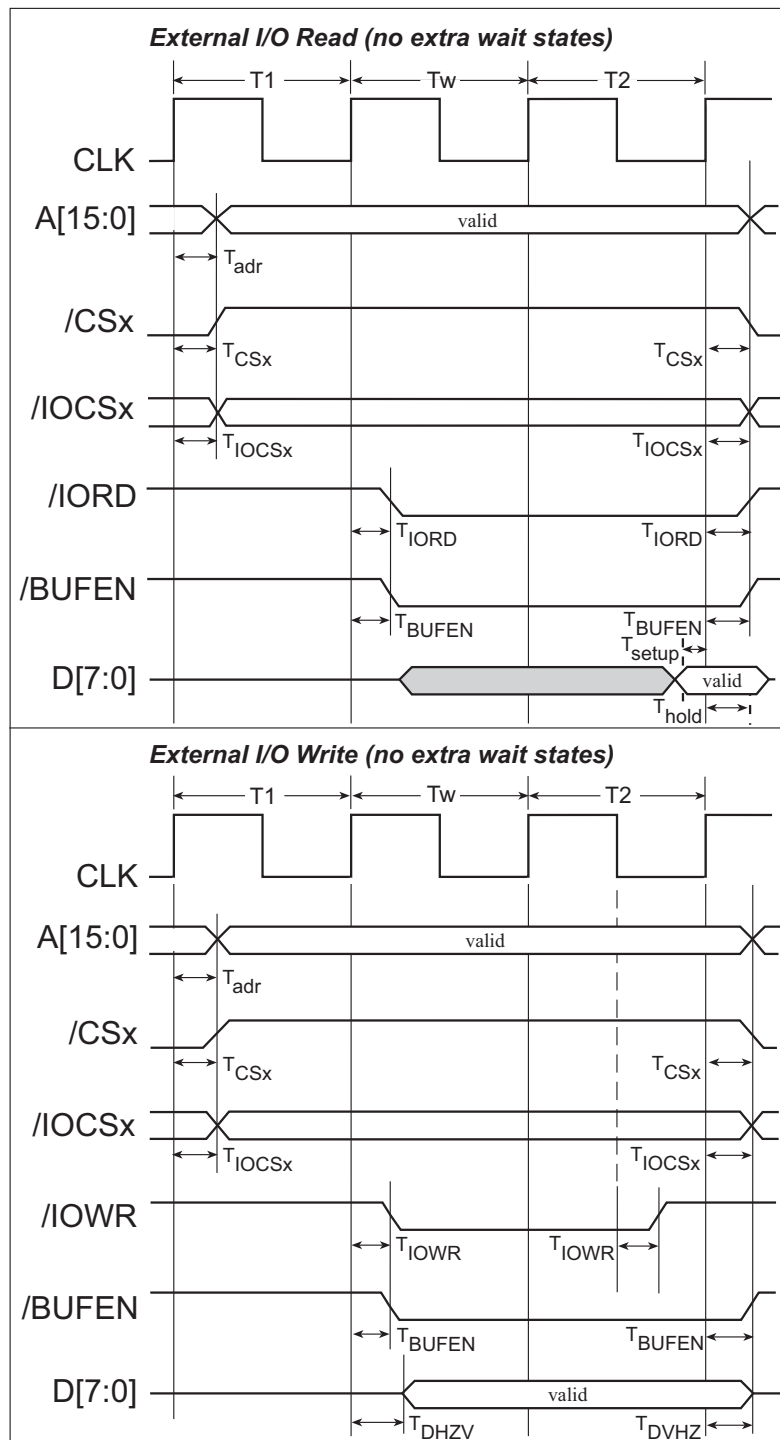

Figure A-4. External I/O Read and Write Cycles—No Extra Wait States

NOTE: /IOCSx can be programmed to be active low (default) or active high.

Table A-7 lists the delays in gross memory access time for several values of V_{DDIO} .

Table A-7. Preliminary Data and Clock Delays

V_{DDIO} (V)	Clock to Address Output Delay (ns)			Data Setup Time Delay (ns)	Worst-Case Spectrum Spreader Delay (ns)		
	30 pF	60 pF	90 pF		0.5 ns setting no dbl / dbl	1 ns setting no dbl / dbl	2 ns setting no dbl / dbl
3.3	6	8	11	1	2.3 / 2.3	3 / 4.5	4.5 / 9
1.8	18	24	33	3	7 / 6.5	8 / 12	11 / 22

The measurements are taken at the 50% points under the following conditions.

- $T = -40^{\circ}\text{C}$ to 85°C , $V = V_{DDIO} \pm 10\%$
- Internal clock to nonloaded CLK pin delay ≤ 1 ns @ $85^{\circ}\text{C}/3.0$ V

The clock to address output delays are similar, and apply to the following delays.

- T_{adr} , the clock to address delay
- T_{CSx} , the clock to memory chip select delay
- T_{IOCSx} , the clock to I/O chip select delay
- T_{IORD} , the clock to I/O read strobe delay
- T_{IOWR} , the clock to I/O write strobe delay
- T_{BUFEN} , the clock to I/O buffer enable delay

The data setup time delays are similar for both T_{setup} and T_{hold} .

When the spectrum spreader is enabled with the clock doubler, every other clock cycle is shortened (sometimes lengthened) by a maximum amount given in the table above. The shortening takes place by shortening the high part of the clock. If the doubler is not enabled, then every clock is shortened during the low part of the clock period. The maximum shortening for a pair of clocks combined is shown in the table.

Technical Note TN227, *Interfacing External I/O with Rabbit Microprocessor Designs*, contains suggestions for interfacing I/O devices to the Rabbit 4000 microprocessors.

A.5 Conformal Coating

The areas around the 32 kHz real-time clock crystal oscillator have had the Dow Corning silicone-based 1-2620 conformal coating applied. The conformally coated area is shown in Figure A-5. The conformal coating protects these high-impedance circuits from the effects of moisture and contaminants over time.

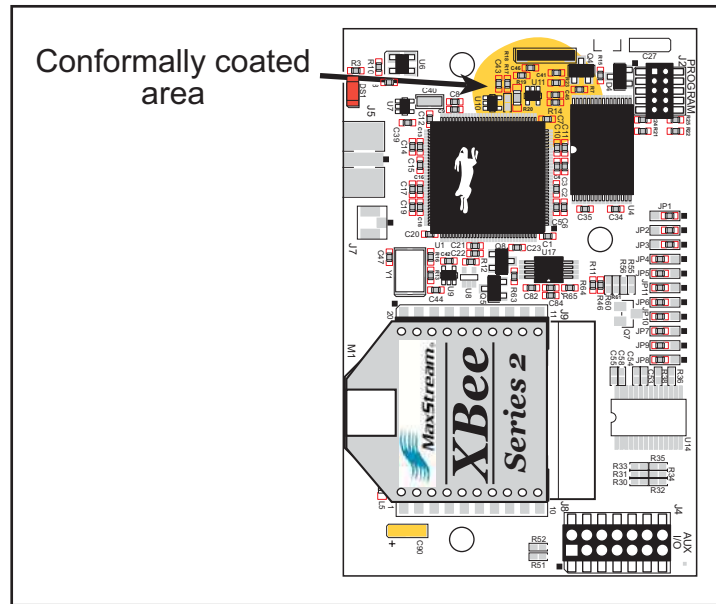

Figure A-5. RCM4510W Areas Receiving Conformal Coating

Any components in the conformally coated area may be replaced using standard soldering procedures for surface-mounted components. A new conformal coating should then be applied to offer continuing protection against the effects of moisture and contaminants.

NOTE: For more information on conformal coatings, refer to Rabbit's Technical Note TN303, *Conformal Coatings*, which is included with the online documentation.

A.6 Jumper Configurations

Figure A-6 shows the header locations used to configure the various RCM4510W options via jumpers.

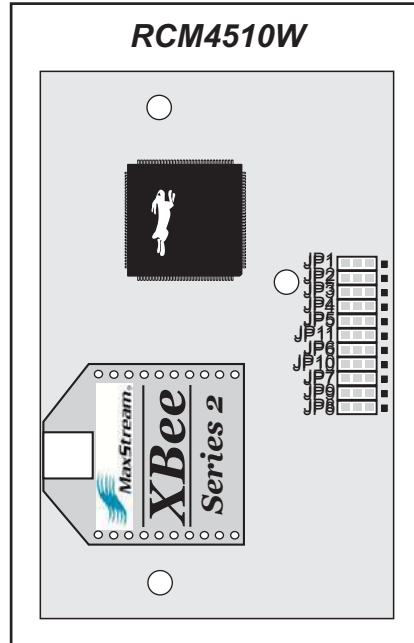

Figure A-6. Location of RCM4510W Configurable Positions

Table A-8 lists the configuration options.

Table A-8. RCM4510W Jumper Configurations

Header	Description	Pins Connected		Factory Default
JP1	PE5 or SMODE0 Output on J1 pin 37	1-2	PE5	×
		2-3	SMODE0	
JP2	PE6 or SMODE1 Output on J1 pin 38	1-2	PE6	×
		2-3	SMODE1	
JP3	PE7 or STATUS Output on J1 pin 39	1-2	PE7	×
		2-3	STATUS	
JP4	LN0 or PD0 on J1 pin 40	1-2	LN0	
		2-3	PD0	×

Table A-8. RCM4510W Jumper Configurations (continued)

Header	Description	Pins Connected		Factory Default
JP5	LN2 or PD2 on J1 pin 42	1-2	LN2	
		2-3	PD2	×
JP6	LN4 or PD4 on J1 pin 44	1-2	LN4	
		2-3	PD4	×
JP7	LN6 or PD6 on J1 pin 46	1-2	LN6	
		2-3	PD6	×
JP8	LN7 or PD7 on J1 pin 47	1-2	LN7	
		2-3	PD7	×
JP9	LN5 or PD5 on J1 pin 45	1-2	LN5	
		2-3	PD5	×
JP10	LN3 or PD3 on J1 pin 43	1-2	LN3	
		2-3	PD3	×
JP11	LN1 or PD1 on J2 pin 41	1-2	LN1	
		2-3	PD1	×

NOTE: The jumper connections are made using 0 Ω surface-mounted resistors.



APPENDIX B. PROTOTYPING BOARD

Appendix B describes the features and accessories of the Prototyping Board, and explains the use of the Prototyping Board to demonstrate the RCM4510W and to build prototypes of your own circuits. The Prototyping Board has power-supply connections and also provides some basic I/O peripherals (RS-232, LEDs, and switches), as well as a prototyping area for more advanced hardware development.

B.1 Introduction

The Prototyping Board included in the Development Kit makes it easy to connect an RCM4510W module to a power supply and a PC workstation for development. It also provides some basic I/O peripherals (RS-232, LEDs, and switches), as well as a prototyping area for more advanced hardware development.

For the most basic level of evaluation and development, the Prototyping Board can be used without modification.

As you progress to more sophisticated experimentation and hardware development, modifications and additions can be made to the board without modifying the RCM4510W module.

The Prototyping Board is shown below in Figure B-1, with its main features identified.

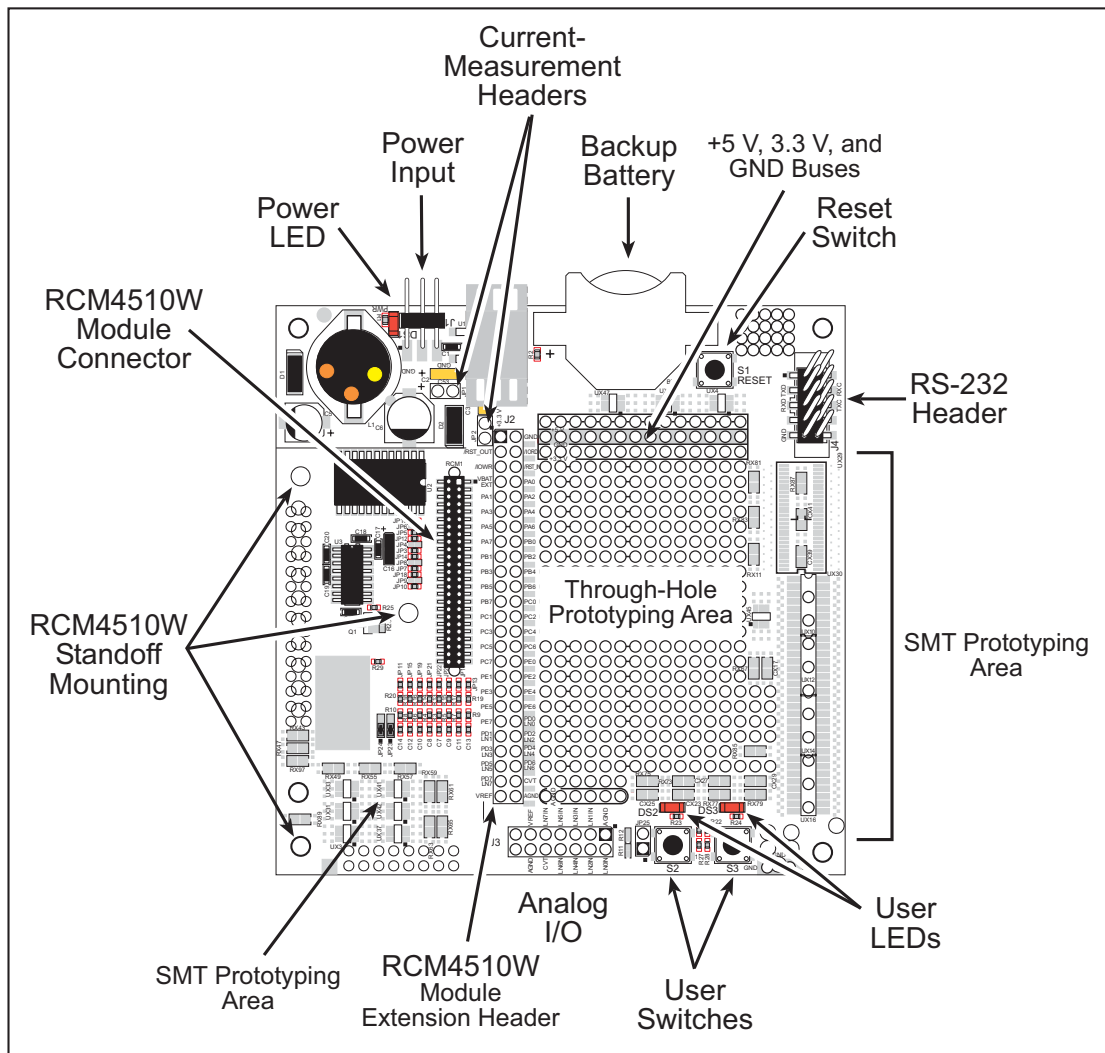

Figure B-1. Prototyping Board

B.1.1 Prototyping Board Features

- **Power Connection**—A 3-pin header is provided for connection to the power supply. Note that the 3-pin header is symmetrical, with both outer pins connected to ground and the center pin connected to the raw V+ input. The cable of the AC adapter provided with the North American version of the Development Kit is terminated with a header plug that connects to the 3-pin header in either orientation. The header plug leading to bare leads provided for overseas customers can be connected to the 3-pin header in either orientation.

Users providing their own power supply should ensure that it delivers 8–24 V DC at 8 W. The voltage regulators will get warm while in use.

- **Regulated Power Supply**—The raw DC voltage provided at the 3-pin header is routed to a 5 V switching voltage regulator, then to a separate 3.3 V linear regulator. The regulators provide stable power to the RCM4510W module and the Prototyping Board.
- **Power LED**—The power LED lights whenever power is connected to the Prototyping Board.
- **Reset Switch**—A momentary-contact, normally open switch is connected directly to the RCM4510W's **/RESET_IN** pin. Pressing the switch forces a hardware reset of the system.
- **I/O Switches and LEDs**—Two momentary-contact, normally open switches are connected to the PB4 and PB5 pins of the RCM4510W module and may be read as inputs by sample applications.

Two LEDs are connected to the PB2 and PB3 pins of the RCM4510W module, and may be driven as output indicators by sample applications.

- **Prototyping Area**—A generous prototyping area has been provided for the installation of through-hole components. +3.3 V, +5 V, and Ground buses run around the edge of this area. Several areas for surface-mount devices are also available. (Note that there are SMT device pads on both top and bottom of the Prototyping Board.) Each SMT pad is connected to a hole designed to accept a 30 AWG solid wire.
- **Module Extension Header**—The complete pin set of the RCM4510W module is duplicated at header J2. Developers can solder wires directly into the appropriate holes, or, for more flexible development, a 2 × 25 header strip with a 0.1" pitch can be soldered into place. See Figure B-4 for the header pinouts.

NOTE: The same Prototyping Board can be used for several series of RabbitCore modules, and so the signals at J2 depend on the signals available on the specific RabbitCore module.

- **Analog Inputs Header**—The analog signals from the RabbitCore module are presented at header J3 on the Prototyping Board. These analog signals are connected via attenuator/filter circuits on the Prototyping Board to the corresponding analog inputs on the RCM4510W module.

NOTE: No analog signals are available on the Prototyping Board with the RCM4510W RabbitCore module installed since no analog signals are present on the RCM4510W's header J1. The auxiliary I/O on the RCM4510W's header J4 cannot be used with the Prototyping Board without modifying the Prototyping Board.

- **RS-232**—Two 3-wire or one 5-wire RS-232 serial ports are available on the Prototyping Board at header J4. A 10-pin 0.1" pitch header strip installed at J4 allows you to connect a ribbon cable that leads to a standard DE-9 serial connector.
- **Current Measurement Option**—You may cut the trace below header JP1 on the bottom side of the Prototyping Board and install a 1 × 2 header strip from the Development Kit to allow you to use an ammeter across the pins to measure the current drawn from the +5 V supply. Similarly, you may cut the trace below header JP2 on the bottom side of the Prototyping Board and install a 1 × 2 header strip from the Development Kit to allow you to use an ammeter across the pins to measure the current drawn from the +3.3 V supply.
- **Backup Battery**—A 2032 lithium-ion battery rated at 3.0 V, 220 mA·h, provides battery backup for the RCM4510W SRAM and real-time clock.

B.2 Mechanical Dimensions and Layout

Figure B-2 shows the mechanical dimensions and layout for the Prototyping Board.

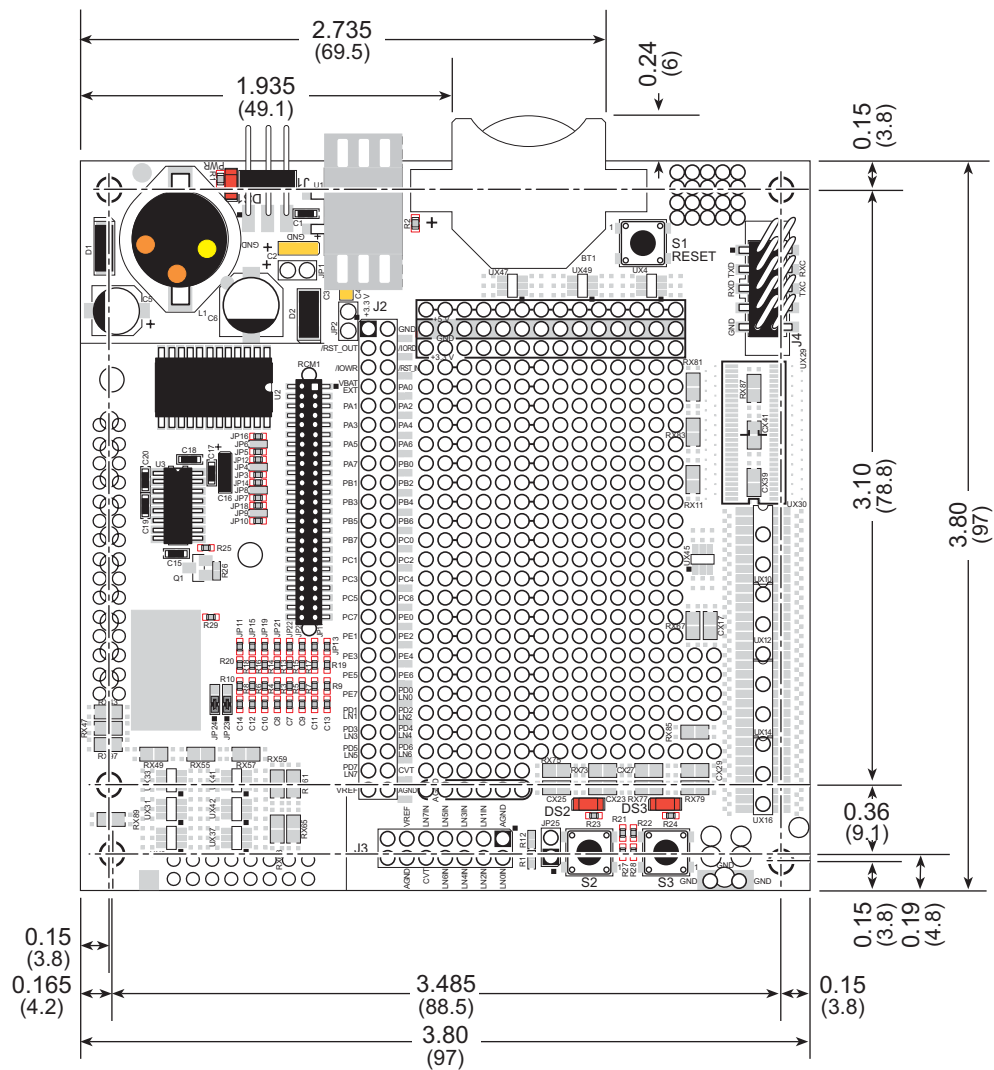

Figure B-2. Prototyping Board Dimensions

NOTE: All measurements are in inches followed by millimeters enclosed in parentheses. All dimensions have a manufacturing tolerance of ± 0.01 " (0.25 mm).

Table B-1 lists the electrical, mechanical, and environmental specifications for the Prototyping Board.

Table B-1. Prototyping Board Specifications

Parameter	Specification
Board Size	3.80" × 3.80" × 0.48" (97 mm × 97 mm × 12 mm)
Operating Temperature	0°C to +70°C
Humidity	5% to 95%, noncondensing
Input Voltage	8 V to 24 V DC
Maximum Current Draw (including user-added circuits)	800 mA max. for +3.3 V supply, 1 A total +3.3 V and +5 V combined
Prototyping Area	1.3" × 2.0" (33 mm × 50 mm) throughhole, 0.1" spacing, additional space for SMT components
Connectors	One 2 × 25 header socket, 1.27 mm pitch, to accept RCM4510W One 1 × 3 IDC header for power-supply connection One 2 × 5 IDC RS-232 header, 0.1" pitch Two unstuffed header locations for analog and RCM4510W signals 25 unstuffed 2-pin header locations for optional configurations

B.3 Power Supply

The RCM4510W requires a regulated 3.0 V – 3.6 V DC power source to operate. Depending on the amount of current required by the application, different regulators can be used to supply this voltage.

The Prototyping Board has an onboard +5 V switching power regulator from which a +3.3 V linear regulator draws its supply. Thus both +5 V and +3.3 V are available on the Prototyping Board.

The Prototyping Board itself is protected against reverse polarity by a Shottky diode at D2 as shown in Figure B-3.

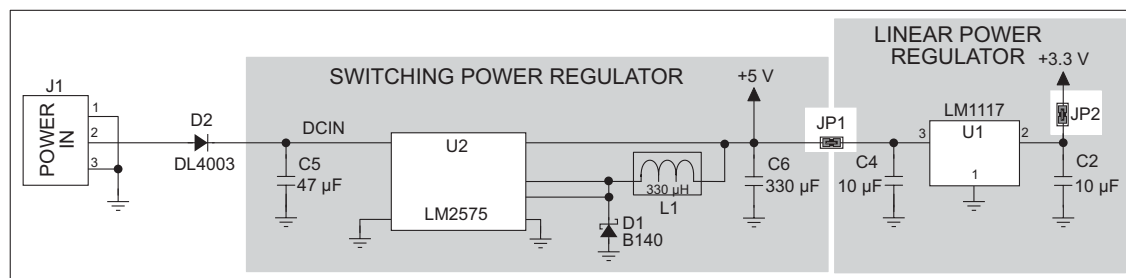

Figure B-3. Prototyping Board Power Supply

B.4 Using the Prototyping Board

The Prototyping Board is actually both a demonstration board and a prototyping board. As a demonstration board, it can be used to demonstrate the functionality of the RCM4510W right out of the box without any modifications to either board.

The Prototyping Board comes with the basic components necessary to demonstrate the operation of the RCM4510W. Two LEDs (DS2 and DS3) are connected to PB2 and PB3, and two switches (S2 and S3) are connected to PB4 and PB5 to demonstrate the interface to the Rabbit 4000 microprocessor. Reset switch S1 is the hardware reset for the RCM4510W.

The Prototyping Board provides the user with RCM4510W connection points brought out conveniently to labeled points at header J2 on the Prototyping Board. Although header J2 is unstuffed, a 2×25 header is included in the bag of parts. RS-232 signals (Serial Ports C and D) are available on header J4. A header strip at J4 allows you to connect a ribbon cable, and a ribbon cable to DB9 connector is included with the Development Kit. The pinouts for these locations are shown in Figure B-4.

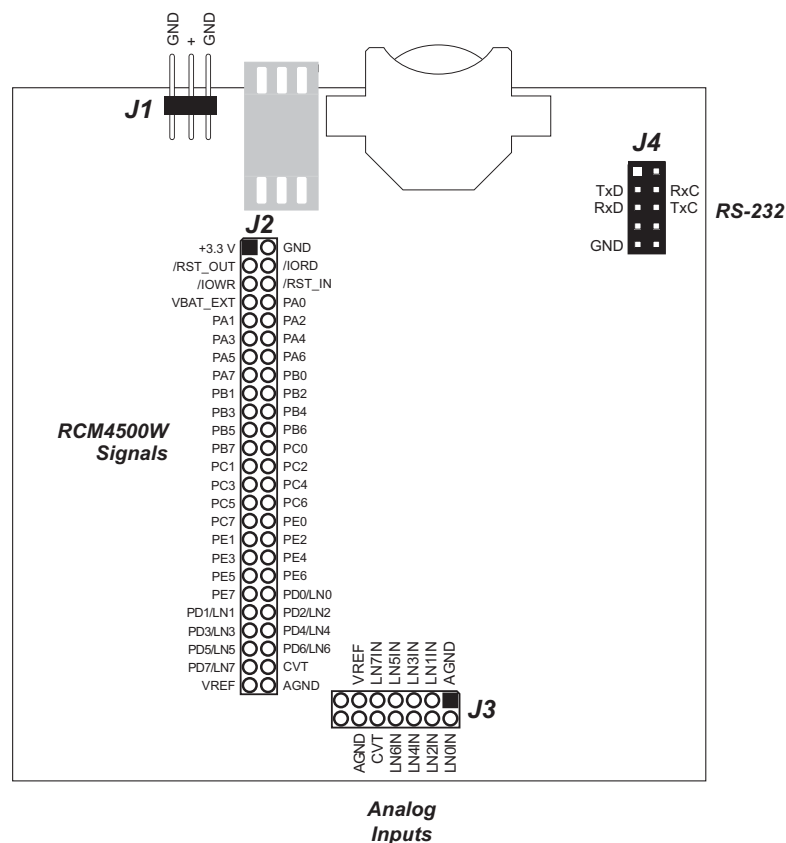

Figure B-4. Prototyping Board Pinout

Although analog signals are shown for labeled points at header location J3 on the Prototyping Board, the analog signals on the RCM4510W are associated with the XBee RF module. These analog signals are not brought out to the Prototyping Board.

All signals from the RCM4510W module are available on header J2 of the Prototyping Board. The remaining ports on the Rabbit 4000 microprocessor are used for RS-232 serial communication. Table B-2 lists the signals on header J2 and, where applicable, explains how they are configured by the `brdInit()` function call for use on the Prototyping Board.

Table B-2. Use of RCM4510W Signals on the Prototyping Board

Pin	Pin Name	Prototyping Board Use
1	+3.3 V	+3.3 V power supply
2	GND	
3	/RST_OUT	Reset output from reset generator
4	/IORD	External read strobe
5	/IOWR	External write strobe
6	/RESET_IN	Input to reset generator
7	VBAT_EXT	External backup battery connection
8–15	PA0–PA7	Output, high
16	PB0	Output, high
17	PB1	Programming port CLKA
18	PB2	LED DS2 (normally high/off)
19	PB3	LED DS3 (normally high/off)
20	PB4	Switch S2 (normally open/pulled up)
21	PB5	Switch S3 (normally open/pulled up)
22–23	PB6–PB7	Output, high
24–25	PC0–PC1	Serial Port D (RS-232, header J4) (high)
26–27	PC2–PC3	Serial Port C (RS-232, header J4) (high)
28–29	PC4–PC5	Serial Port B (used by XBee RF module)
30–31	PC6–PC7	Serial Port A (programming port) (high)
32–39	PE0–PE7	Output, high
40–47	PD0–PD7	Output, high
48	CONVERT	Not available
49	VREF	Not available
50	GND	

There is a 1.3" × 2" through-hole prototyping space available on the Prototyping Board. The holes in the prototyping area are spaced at 0.1" (2.5 mm). +3.3 V, +5 V, and GND traces run along the top edge of the prototyping area for easy access. Small to medium circuits can be prototyped using point-to-point wiring with 20 to 30 AWG wire between the prototyping area, the +3.3 V, +5 V, and GND traces, and the surrounding area where surface-mount components may be installed. Small holes are provided around the surface-mounted components that may be installed around the prototyping area.

B.4.1 Adding Other Components

There are pads for 28-pin TSSOP devices, 16-pin SOIC devices, and 6-pin SOT devices that can be used for surface-mount prototyping with these devices. There are also pads that can be used for SMT resistors and capacitors in an 0805 SMT package. Each component has every one of its pin pads connected to a hole in which a 30 AWG wire can be soldered (standard wire wrap wire can be soldered in for point-to-point wiring on the Prototyping Board). Because the traces are very thin, carefully determine which set of holes is connected to which surface-mount pad.

B.4.2 Measuring Current Draw

The Prototyping Board has a current-measurement feature available at header locations JP1 and JP2 for the +5 V and +3.3 V supplies respectively. To measure current, you will have to cut the trace on the bottom side of the Prototyping Board corresponding to the power supply or power supplies whose current draw you will be measuring. Header locations JP1 and JP2 are shown in Figure B-5. Then install a 1 × 2 header strip from the Development Kit on the top side of the Prototyping Board at the header location(s) whose trace(s) you cut. The header strip(s) will allow you to use an ammeter across their pins to measure the current drawn from that supply. Once you are done measuring the current, place a jumper across the header pins to resume normal operation.

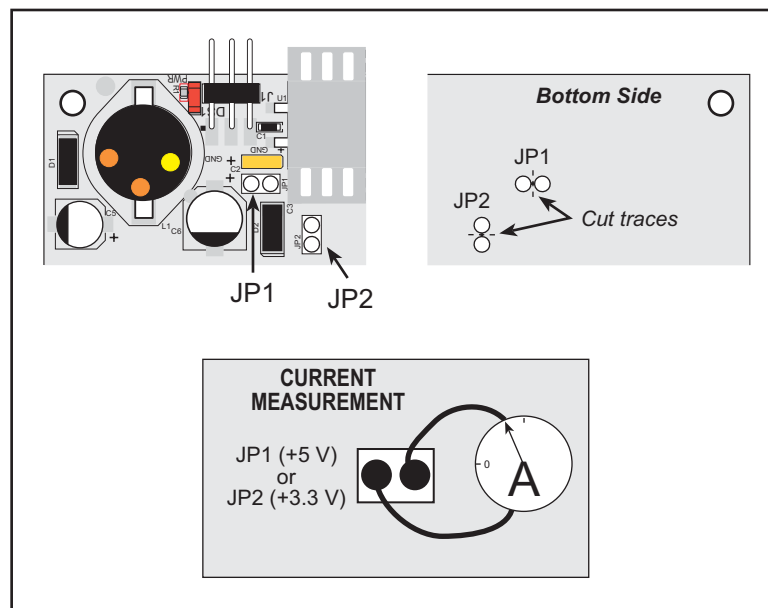

Figure B-5. Prototyping Board Current-Measurement Option

NOTE: Once you have cut the trace below header location JP1 or JP2, you must either be using the ammeter or have a jumper in place in order for power to be delivered to the Prototyping Board.

B.4.3 Analog Features

The Prototyping Board has typical support circuitry installed to complement the ADS7870 A/D converter chip, which is available on other RabbitCore modules based on the Rabbit 4000 microprocessor, but is not installed on the RCM4510W model. The analog inputs from the auxiliary I/O on the RCM4510W's header J4 cannot be used with the Prototyping Board without modifying the Prototyping Board.

B.4.4 Serial Communication

The Prototyping Board allows you to access the serial ports from the RCM4510W module. Table B-3 summarizes the configuration options.

Table B-3. Prototyping Board Serial Port Configurations

Serial Port	Header	Default Use	Alternate Use
A	J2	Programming Port	RS-232
B	J2	XBee RF Module	RS-232
C	J2, J4	RS-232	—
D	J2, J4	RS-232	—
E	J2	—	—
F	J2	—	—

Serial Ports E and F may be used as serial ports, or the corresponding pins at header location J2 may be used as parallel ports.

B.4.4.1 RS-232

RS-232 serial communication on header J4 on both Prototyping Boards is supported by an RS-232 transceiver installed at U3. This transceiver provides the voltage output, slew rate, and input voltage immunity required to meet the RS-232 serial communication protocol. Basically, the chip translates the Rabbit 4000's signals to RS-232 signal levels. Note that the polarity is reversed in an RS-232 circuit so that a +3.3 V output becomes approximately -10 V and 0 V is output as +10 V. The RS-232 transceiver also provides the proper line loading for reliable communication.

RS-232 can be used effectively at the RCM4510W module's maximum baud rate for distances of up to 15 m.

RS-232 flow control on an RS-232 port is initiated in software using the `serXflowcontrolOn` function call from `RS232.LIB`, where `X` is the serial port (C or D). The locations of the flow control lines are specified using a set of five macros.

`SERX_RTS_PORT`—Data register for the parallel port that the RTS line is on (e.g., `PCDR`).

`SERA_RTS_SHADOW`—Shadow register for the RTS line's parallel port (e.g., `PCDRShadow`).

`SERA_RTS_BIT`—The bit number for the RTS line.

`SERA_CTS_PORT`—Data register for the parallel port that the CTS line is on (e.g., `PCDRShadow`).

`SERA_CTS_BIT`—The bit number for the CTS line.

Standard 3-wire RS-232 communication using Serial Ports C and D is illustrated in the following sample code.

```
#define CINBUFSIZE 15 // set size of circular buffers in bytes
#define COUTBUFSIZE 15

#define DINBUFSIZE 15
#define DOUTBUFSIZE 15

#define MYBAUD 115200 // set baud rate
#endif

main(){
    serCopen(_MYBAUD); // open Serial Ports C and D
    serDopen(_MYBAUD);
    serCwrFlush(); // flush their input and transmit buffers
    serCrdFlush();
    serDwrFlush();
    serDrdFlush();
    serCclose(_MYBAUD); // close Serial Ports C and D
    serDclose(_MYBAUD);
}
```

B.5 Prototyping Board Jumper Configurations

Figure B-6 shows the header locations used to configure the various Prototyping Board options via jumpers.

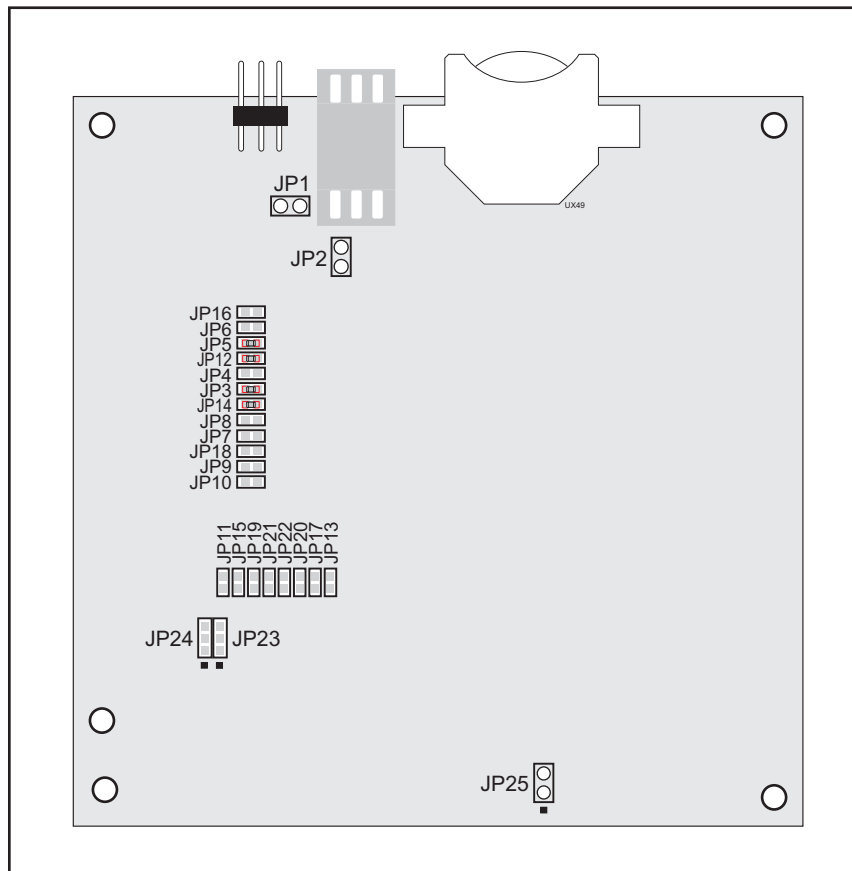

Figure B-6. Location of Configurable Jumpers on Prototyping Board

Table B-4 lists the configuration options using either jumpers or 0 Ω surface-mount resistors.

Table B-4. RCM4510W Prototyping Board Jumper Configurations

Header	Description	Pins Connected		Factory Default
JP1	+5 V Current Measurement	1-2	Via trace or jumper	Connected
JP2	+3.3 V Current Measurement	1-2	Via trace or jumper	Connected
JP3 JP4	PC0/TxD/LED DS2	JP3 1-2	TxD on header J4	×
		JP4 1-2	PC0 to LED DS2	
		n.c.	PC0 available on header J2	

Table B-4. RCM4510W Prototyping Board Jumper Configurations (continued)

Header	Description	Pins Connected		Factory Default
JP5 JP6	PC1/RxD/Switch S2	JP5 1-2	RxD on header J4	×
		JP6 1-2	PC1 to Switch S2	
		n.c.	PC1 available on header J2	
JP7 JP8	PC2/TxC/LED DS3	JP7 1-2	TxC on header J4	×
		JP6 1-2	PC2 to LED DS3	
		n.c.	PC2 available on header J2	
JP9 JP10	PC3/RxC/Switch S3	JP9 1-2	PC3 to Switch S3	
		JP10 1-2	RxC on header J4	×
		n.c.	PC3 available on header J2	
JP11	LN0 buffer/filter to RCM4510W	1-2		Connected
JP12	PB2/LED DS2	1-2	Connected: PB2 to LED DS2	×
		n.c.	PB2 available on header J2	
JP13	LN1 buffer/filter to RCM4510W	1-2		Connected
JP14	PB3/LED DS3	1-2	Connected: PB3 to LED DS3	×
		n.c.	PB3 available on header J2	
JP15	LN2 buffer/filter to RCM4510W	1-2		Connected
JP16	PB4/Switch S2	1-2	Connected: PB4 to Switch S2	×
		n.c.	PB4 available on header J2	
JP17	LN3 buffer/filter to RCM4510W	1-2		Connected
JP18	PB5/Switch S3	1-2	Connected: PB5 to Switch S3	×
		n.c.	PB5 available on header J2	
JP19	LN4 buffer/filter to RCM4510W	1-2		Connected

Table B-4. RCM4510W Prototyping Board Jumper Configurations (continued)

Header	Description	Pins Connected		Factory Default
JP20	LN5 buffer/filter to RCM4510W	1–2		Connected
JP21	LN6 buffer/filter to RCM4510W	1–2		Connected
JP22	LN7 buffer/filter to RCM4510W	1–2		Connected
JP23	LN4_IN–LN6_IN	1–2	Tied to analog ground	×
		2–3	Tied to VREF	
JP24	LN0_IN–LN3_IN	1–2	Tied to analog ground	×
		2–3	Tied to VREF	
JP25	Thermistor Location	1–2		n.c.

NOTE: Jumper connections JP3–JP10, JP12, JP14, JP16, JP18, JP23, and JP24 are made using 0 Ω surface-mounted resistors. Jumper connections JP11, JP13, JP15, JP17, and JP19–JP22 are made using 470 Ω surface-mounted resistors.

APPENDIX C. POWER SUPPLY

Appendix C provides information on the current requirements of the RCM4510W, and includes some background on the chip select circuit used in power management.

C.1 Power Supplies

The RCM4510W requires a regulated 3.3 V DC $\pm 5\%$ power source. The RabbitCore design presumes that the voltage regulator is on the user board, and that the power is made available to the RCM4510W board through header J1.

An RCM4510W with no loading at the outputs operating at 29.48 MHz typically draws 80 mA, and may draw up to 150 mA while the XBee RF module is transmitting or receiving.

C.1.1 Battery Backup

The RCM4510W does not have a battery, but there is provision for a customer-supplied battery to back up the data SRAM and keep the internal Rabbit 4000 real-time clock running.

Header J1, shown in Figure C-1, allows access to the external battery. This header makes it possible to connect an external 3 V power supply. This allows the SRAM and the internal Rabbit 4000 real-time clock to retain data with the RCM4510W powered down.

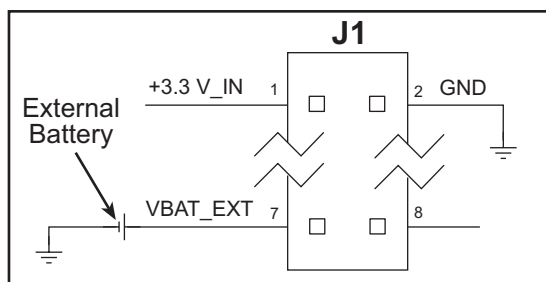

Figure C-1. External Battery Connections at Header J1

A lithium battery with a nominal voltage of 3 V and a minimum capacity of 165 mA-h is recommended. A lithium battery is strongly recommended because of its nearly constant nominal voltage over most of its life.

The drain on the battery by the RCM4510W is typically 7.5 μA when no other power is supplied. If a 165 mA·h battery is used, the battery can last about 2.5 years:

$$\frac{165 \text{ mA}\cdot\text{h}}{7.5 \mu\text{A}} = 2.5 \text{ years.}$$

The actual battery life in your application will depend on the current drawn by components not on the RCM4510W and on the storage capacity of the battery. The RCM4510W does not drain the battery while it is powered up normally.

Cycle the main power off/on after you install a backup battery for the first time, and whenever you replace the battery. This step will minimize the current drawn by the real-time clock oscillator circuit from the backup battery should the RCM4510W experience a loss of main power.

NOTE: Remember to cycle the main power off/on any time the RCM4510W is removed from the Prototyping Board or motherboard since that is where the backup battery would be located.

Rabbit's Technical Note TN235, *External 32.768 kHz Oscillator Circuits*, provides additional information about the current draw by the real-time clock oscillator circuit.

C.1.2 Battery-Backup Circuit

Figure C-2 shows the battery-backup circuit.

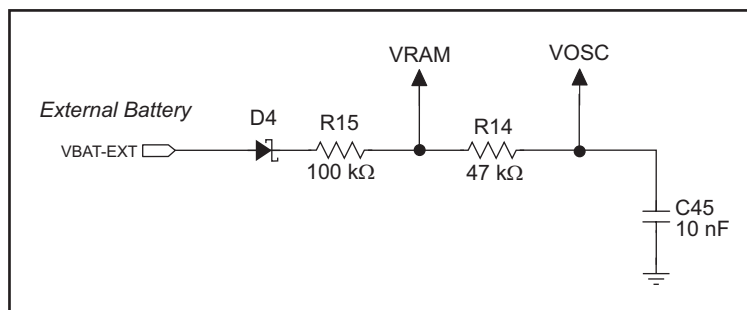

Figure C-2. RCM4510W Backup Battery Circuit

The battery-backup circuit serves three purposes:

- It reduces the battery voltage to the SRAM and to the real-time clock, thereby limiting the current consumed by the real-time clock and lengthening the battery life.
- It ensures that current can flow only *out* of the battery to prevent charging the battery.
- A voltage, VOSC, is supplied to U11, which keeps the 32.768 kHz oscillator working when the voltage begins to drop.

C.1.3 Reset Generator

The RCM4510W uses a reset generator to reset the Rabbit 4000 microprocessor when the voltage drops below the voltage necessary for reliable operation. The reset occurs between

2.85 V and 3.00 V, typically 2.93 V. Since the RCM4510W will operate at voltages as low as 3.0 V, exercise care when operating close to the 3.0 V minimum voltage (for example, keep the power supply as close as possible to the RCM4510W) since your RCM4510W could reset unintentionally.

The RCM4510W has a reset output, pin 3 on header J1.

C.1.4 XBee RF Module Power Supply

The XBee RF module is isolated from digital noise generated by other components by way of a low-pass filter composed of L5 and C90 on the RCM4510W as shown in Figure C-3. The filtered power supply powers the XBee RF module, and is available via pin 8 of auxiliary I/O header J4 on the RCM4510W module. If you draw on this filtered power supply, the maximum current draw is 25 mA.

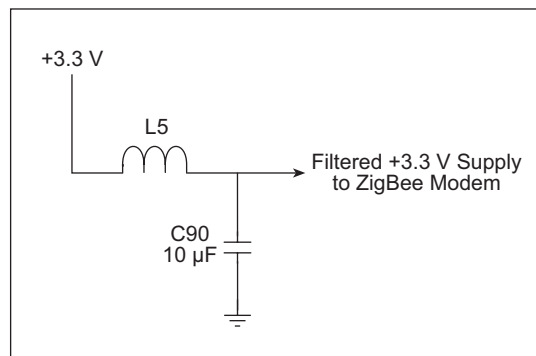

Figure C-3. XBee RF Module Supply Circuit

C.2 Powerdown Mode

The XBee RF module can power down the remaining RCM4510W circuitry via the `zb_Rabbit_poweroff()` or the `xb_sleep()` Dynamic C function calls. The real-time clock and the data SRAM will still be powered during the powerdown from the +3.3 V DC supplied to the RCM4510W module via header J1 as long as that voltage exceeds the voltage of the backup battery.

APPENDIX D. ADDITIONAL CONFIGURATION INSTRUCTIONS

Appendix D provides information on how to find the latest firmware for the XBee RF module and the Digi® XBee USB used as the ZigBee coordinator, and how to install the firmware.

D.1 XBee RF Module Firmware Downloads

By default, the RCM4510W is shipped from the factory with firmware to operate as either a router or as an end device in a mesh network. You will need to run the **MODEMFWLOAD.C** sample program in the Dynamic C **SAMPLES\RCM4500W\XBee** folder to download the firmware needed to operate the RCM4510W as a coordinator.

NOTE: You can verify the firmware version by running the **AT_INTERACTIVE.C** sample program in the Dynamic C **SAMPLES\XBEE** folder and by entering the command **ATVR <Enter>** to get the version number displayed in the Dynamic C **STDIO** window.

CAUTION: Different firmware versions are likely to interact with the Dynamic C libraries in different ways. Rabbit has tested the firmware associated with a particular version of Dynamic C for correct operation, and only this version is included on the Dynamic C CD-ROM — do not use any other firmware versions with that version of Dynamic C.

Once you have successfully loaded the firmware, compile and run another sample program to make sure the **MODEMFWLOAD.C** sample program does not inadvertently reload (or partially reload) the firmware.

If you are uploading firmware because you upgraded to a more recent Dynamic C release, remember to recompile your applications using the new version of Dynamic C once you have uploaded the new firmware.

D.1.1 Dynamic C v. 10.44 and Later

Encrypted libraries have been created within Dynamic C for the firmware. The three ZigBee PRO libraries are in the **LIB\Rabbit4000\XBee\XBee_Firmware\ZigBee** folder.

- A Dynamic C library of the type **XB24-ZB_21...LIB** is used for a coordinator RCM4510W.
- A Dynamic C library of the type **XB24-ZB_23...LIB** is used for a router RCM4510W.
- A Dynamic C library of the type **XB24-ZB_29...LIB** is used for an end-device RCM4510W.

There are also two ZNet 2.5 libraries in the `LIB\Rabbit4000\XBee\XBee_Firmware\ZNet` folder.

- A Dynamic C library of the type `XB24-B_ZigBee_...41.LIB` is used for a coordinator RCM4510W.
- A Dynamic C library of the type `XB24-B_ZigBee_...47.LIB` is used for an end-device/router RCM4510W.

Make the following modifications to the `MODEMFWLOAD.C` sample program before you run it according to whether you will be using the RCM4510W as a coordinator, a router, or an end device.

- Select the XBee role macro according to whether the RCM4510W is being used as a coordinator, a router or an end device.

```
#define XBEE_ROLE NODE_TYPE_COORD
#define XBEE_ROLE NODE_TYPE_ROUTER
#define XBEE_ROLE NODE_TYPE_ENDDEV
```

- The RCM4510W uses either the ZNet 2.5 protocol or the ZB protocol. Make sure the `#define` statement calls for the protocol used.

```
#define XBEE_PROTOCOL XBEE_PROTOCOL_ZNET
#define XBEE_PROTOCOL XBEE_PROTOCOL_ZB
```

D.1.2 Dynamic C v. 10.21 (RCM4510W preview and standard versions)

Encrypted libraries have been created within Dynamic C for the two types of firmware. The two libraries provided are in the `LIB\Rabbit4000\RCM4xxx\RCM45xxW_XBee_firmware` folder.

- A Dynamic C library of the type `XB24-B_ZigBee_11...LIB` is used for a coordinator RCM4510W.
- A Dynamic C library of the type `XB24-B_ZigBee_13...LIB` is used for an end device/router RCM4510W.

Make the following modifications to the `MODEMFWLOAD.C` sample program before you run it according to whether you will be using the RCM4510W as a coordinator, a router, or an end device.

- Uncomment the following line if you will be using the RCM4510W as a coordinator.

```
#define ZIGBEE_COORDINATOR
```

- Uncomment either of the following two lines if you will be using the RCM4510W as a router or an end device. The same firmware will be uploaded to the RCM4510W regardless of which line is commented out.

```
#define ZIGBEE_ROUTER
#define ZIGBEE_ENDDEV
```

D.1.3 Dynamic C v. 10.11 (RCM4510W preview version only)

The coordinator and end-device/router firmware is provided in the Dynamic C **SAMPLES\RCM4500W\MODEMFW** folder.

- Firmware of the type **XB24-B_ZigBee_11...ebl** is used for a coordinator RCM4510W.
- Firmware of the type **XB24-B_ZigBee_13...ebl** is used for an end device/router RCM4510W.

When you use the bootloader function, you will have to provide a file read function that supplies the binary image in record sizes specified by the **xmodem** protocol. The read function will have the following prototype.

```
char *fileread(int recordNumber, int recordSize)
```

The function will return the address of a buffer containing the data. A NULL return signifies the end of the file.

Before you compile and run this sample program, modify the **ximport** statement to point to the binary image file you will be downloading.

```
#ximport "MODEMFW/Coordinator/XB24-B_ZigBee_1118.ebl" zb_ebl_file
```

In this example, the **XB24-B_ZigBee_1118.ebl** file is in the Dynamic C **SAMPLES\RCM4500W\MODEMFW\Coordinator** folder. If you downloaded a firmware update to another location on your hard drive, you would change the directory path accordingly as in the following example.

```
#ximport "/temp/XB24-B_ZigBee_1118.ebl" zb_ebl_file
```

To see the details of what is happening while the sample program runs, you should **#define** the following.

```
#define ZB_VERBOSE  
#define XMODEM_DEBUG
```

D.2 Digi® XBee USB Configuration

You may experience difficulty when you use the ZigBee sample programs and the Digi® XBee USB with the default settings if you are working simultaneously with more than one ZigBee coordinator.

Section 6.2.2 explains how to set up the RCM4510W configuration patterns for the sample programs via macros in the Dynamic C `LIB\Rabbit4000\XBee\XBEE_API.LIB` library folder.

ZB	ZNet 2.5
<p><i>Extended PAN ID</i> — the 64-bit network ID. Defaults to <code>DEFAULT_PANID</code> if set in the Dynamic C <code>LIB\Rabbit4000\XBee\XBEE_API.LIB</code> library, otherwise defaults to <code>0x0123456789abcdef</code> to match the default used on the Digi® XBee USB.</p> <p>If set to <code>0x00</code>, tells coordinators to “select a random extended PAN ID,” and tells routers and end devices to “join any network.”</p> <p>Change the extended PAN ID if you are developing simultaneously with more than one ZigBee coordinator.</p> <pre>#define DEFAULT_EXTPANID "0x0123456789abcdef"</pre>	<p><i>PAN ID</i> — the network ID. Defaults to <code>0x0234</code> via the macro in the Dynamic C <code>LIB\Rabbit4000\XBee\XBEE_API.LIB</code> library. Change the PAN ID if you are developing simultaneously with more than one ZigBee coordinator.</p> <pre>#define DEFAULT_PANID 0x0234</pre>

Channel mask — defaults to `0x1FFE`, i.e., all 12 possible channels via the macro in the Dynamic C `LIB\Rabbit4000\ZigBee\XBEE_API.LIB` library.

```
#define DEFAULT_CHANNELS ZB_DEFAULT_CHANNELS
```

For example, to limit the channels to three channels, the macro would read as follows.

```
#define DEFAULT_CHANNELS 0x000E
```

The same configurations must then be applied to the Digi® XBee USB via Digi’s X-CTU utility. If you have not previously used this utility, install it from the Dynamic C `Utilities\X-CTU` folder by double-clicking `Setup_XCTU_xxxx.exe` (where `xxxx` is the version number),

Continue the following steps with the Digi® XBee USB connected to your PC’s USB port. Since the ZigBee Utility `XBEE_GPIO_GUI.exe` will conflict with X-CTU, first close the ZigBee Utility if it is running.

1. Start X-CTU from the desktop icon and set the “PC Settings” tab to **115200** baud, **HARDWARE** flow control, **8** data bits, parity **NONE**, **1** stop bit.
2. On the “PC Settings” tab, check the “Enable API” box under “Host Setup.”

3. On the “PC Settings” tab, select the “USB Serial Port” corresponding to the USB serial port the Digi® XBee USB is connected to and click “Test/Query.” You should see a response showing the Modem Type (XB 24-B) and the firmware version. Click **OK**.

Note that several USB serial ports could be listed. If you select a serial port without the Digi® XBee USB connected, the X-CTU response to “Test/Query.” will be “communication with modem ... OK,” but the modem type will be unknown, and the firmware version will be blank.

If you get a message that X-CTU is unable to open the COM port, verify that you selected the COM port with the “USB Serial Port,” then try unplugging the Digi® XBee USB from the USB slot and plugging it back in. Now click “Test/Query” again.

4. Under the “Modem Configuration” tab click the “Read” button. X-CTU will now display the networking and I/O parameters for the Digi® XBee USB being used as the ZigBee coordinator.

Modem: XBEE XB24-ZB

Function Set: ZIGBEE COORDINATOR API (do not select other settings)

Version: the version of the firmware included with the version of Dynamic C you are using (should be of the type 21...)

5. Now set the networking parameters in your project defines or in the sample program to match the parameters in the Dynamic C `LIB\Rabbit4000\XBee\XBEE_API.LIB` library.
6. Now set the networking parameters in your project defines or in the sample program to match the parameters in the Dynamic C `LIB\Rabbit4000\XBee\XBEE_API.LIB` library.

Networking

(D) CH - Operating Channel — this is the operating channel you could see when you ran the **AT_INTERACTIVE.C** sample program in the Dynamic C `SAMPLES\XBEE` folder by entering the command `ATCH <Enter>`. This channel information cannot be changed from the X-CTU utility.

(0123456789ABCDEF) ID - Extended Pan ID — set the new extended PAN ID that follows 0x to match the `DEFAULT_EXTPANID` macro.

(1FFE) SC - Scan Channels - set the new value for the channels to scan, E, for example, to match the new setting in the macro.

```
#define DEFAULT_CHANNELS 0x000E
```

7. Finish by clicking the “Write” button.

We are including a profile file (`xBee-USB ZB defaults.pro`) in the `Utilities/X-CTU` folder to load a Digi® XBee USB with default settings. Once the Digi® XBee USB is connected to an available USB port on your PC, start the X-CTU utility. Click the “Load” button in the **Profile** section, navigate to the `.pro` file, and it will set all of the defaults. Then click the “Write” button to write the settings to the Digi® XBee USB.

D.2.1 Additional Reference Information

Check [Digi's Web site](#) for the latest information and documentation on the XBee RF module, the X-CTU utility, and the Digi® XBee USB. Note that the XBee® and the XBee PRO® RF modules are presently not compatible with the XBeeRF module used with the RCM4510W, but the general documentation about ZigBee and the use of AT commands for the XBee® and the XBee PRO® RF modules is relevant.

D.2.2 Update Digi® XBee USB Firmware

The firmware version used by the Digi® XBee USB must correspond to the firmware version installed on the RCM4510W. If you have updated the RCM4510W firmware (or you have a need to re-install the firmware on the Digi® XBee USB), the corresponding firmware for the Digi® XBee USB is in the Dynamic C `Utilities\X-CTU\MODEMFW` folder.

- Remember to record the extended PAN ID, NI, and other parameters you are using.
- Firmware of the type `XB24-ZB_21... .zip` is used for the Digi® XBee USB coordinator.

CAUTION: Different firmware versions are likely to interact with the Dynamic C libraries in different ways. Rabbit has tested the firmware associated with a particular version of Dynamic C for correct operation, and only this version is included on the Dynamic C CD-ROM — do not use any other firmware versions with that version of Dynamic C.

1. Start X-CTU from the desktop icon and set the “PC Settings” tab to **9600** baud, **HARDWARE** flow control, **8** data bits, parity **NONE**, **1** stop bit.
2. On the “PC Settings” tab, check the “Enable API” box under “Host Setup.”
3. On the “PC Settings” tab, select the “USB Serial Port” and click “Test/Query.” You should see a response showing the Modem Type (XB 24 B) and the firmware version. Click **OK**.

Note that several USB serial ports could be listed. If you select a serial port without the Digi® XBee USB connected, the X-CTU response to “Test/Query.” will be “communication with modem ... OK,” but the modem type will be unknown, and the firmware version will be blank.

If you get a message that X-CTU is unable to open the COM port, verify that you selected the COM port with the “USB Serial Port,” then try unplugging the Digi® XBee USB from the USB slot and plugging it back in. Now click “Test/Query” again.

4. Under the “Modem Configuration” tab click the “Read” button. X-CTU will now display the networking and I/O parameters for the Digi® XBee USB.

Modem: XBEE XB24-ZB

Function Set: ZIGBEE COORDINATOR API (do not select other settings)

Version: the version of the firmware included with the version of Dynamic C you are using

5. Click the “Read” button, select XB24-B as the Modem type; select ZIGBEE COORDINATOR API as the Function Set, and 21... as the Version, then click “Write.”
6. When the process is complete set the PANID, NI, and other parameters to the values you were using before the firmware was upgraded.

INDEX

- A**
 - additional information
 - online documentation 7
 - analog inputs
 - function calls
 - zb_adc_in() 55
 - B**
 - battery backup
 - battery life 98
 - circuit 98
 - external battery connections 97
 - real-time clock 98
 - reset generator 98
 - use of battery-backed SRAM 48
 - board initialization
 - function calls 50
 - brdInit() 50
 - bus loading 77
 - C**
 - clock doubler 42
 - cloning 48
 - include firmware upgrade in cloned application 49
 - configuration
 - Digi® XBee USB (ZigBee coordinator) 104
 - conformal coating 80
 - D**
 - Development Kit 5
 - AC adapter 5
 - Getting Started instructions 5
 - programming cable 5
 - Digi® XBee USB (ZigBee coordinator)
 - configuration 104
 - uploading new firmware . 106
 - digital I/O 26
 - function calls 47
 - digInAlert() 51
 - timedAlert() 51
 - zb_dio_in() 54
 - zb_dio_out() 54
 - zb_io_init() 52
 - I/O buffer sourcing and sinking limits 77
 - memory interface 33
 - SMODE0 33, 36
 - SMODE1 33, 36
 - dimensions
 - Prototyping Board 87
 - RCM4510W 70
 - Dynamic C 6, 9, 14, 45
 - add-on modules 9, 56
 - installation 9
 - battery-backed SRAM 48
 - libraries
 - RCM45xxW.LIB 50
 - protected variables 48
 - Rabbit Embedded Security Pack 6, 56
 - sample programs 18
 - standard features
 - debugging 46
 - telephone-based technical support 6, 56
 - upgrades and patches 56
 - version compatibility 6
- E**
 - exclusion zone 71
 - external I/O bus 33
- F**
 - features 2
 - Prototyping Boards 84, 85
- firmware download
 - Digi® XBee USB 106
 - firmware updates 106
 - via cloned application 49
 - XBee RF module 101
 - coordinator vs. end device/router 102, 103
 - firmware updates . 101, 106
- flash memory addresses
 - user blocks 43
- H**
 - hardware connections
 - install RCM4510W on Prototyping Board 11
 - power supply 13
 - programming cable 12
- I**
 - I/O buffer sourcing and sinking limits 77
- J**
 - jumper configurations
 - Prototyping Board 94
 - JP1 (+5 V current measurement) 94
 - JP1 (LN0 buffer/filter to RCM4510W) 95
 - JP12 (PB2/LED DS2) ... 95
 - JP13 (LN1 buffer/filter to RCM4510W) 95
 - JP14 (PB3/LED DS3) ... 95
 - JP15 (LN2 buffer/filter to RCM4510W) 95
 - JP16 (PB4/Switch S2) ... 95
 - JP17 (LN3 buffer/filter to RCM4510W) 95
 - JP18 (PB5/Switch S2) ... 95

jumper configurations			
Prototyping Board (continued)			
JP19 (LN4 buffer/filter to RCM4510W)	95	
JP2 (+ 3.3 V current measurement)	94	
JP20 (LN5 buffer/filter to RCM4510W)	96	
JP21 (LN6 buffer/filter to RCM4510W)	96	
JP22 (LN7 buffer/filter to RCM4510W)	96	
JP23 (analog inputs LN4–LN6 configuration)	96	
JP24 (analog inputs LN0–LN3 configuration)	96	
JP3–JP4 (PC0/TxD/LED DS2)	94	
JP5–JP6 (PC1/RxD/Switch S2)	95	
JP7–JP8 (PC2/TxC/LED DS3)	95	
JP9–JP10 (PC3/RxC/Switch S3)	95	
RCM4510W	81	
JP1 (LN0 or PD0 on J1)	81	
JP10 (PE5 or SMODE0 output on J1)	81	
JP11 (PE6 or SMODE1 output on J1)	81	
JP12 (PE7 or STATUS output on J1)	81	
JP2 (LN2 or PD2 on J1)	82	
JP2 (LN6 or PD6 on J1)	82	
JP4 (LN7 or PD7 on J1)	82	
JP5 (LN5 or PD5 on J1)	82	
JP6 (LN4 or PD4 on J1)	82	
JP7 (LN3 or PD3 on J1)	82	
JP9 (LN1 or PD1 on J1)	82	
jumper locations	81	
O			
onchip-encryption RAM			
how to use	19	
options	7	
Mesh Network Add-On Kit	7	
P			
pinout			
Prototyping Board	89	
RCM4510W			
alternate configurations	28	
RCM4510W headers	26	
power supplies			
+3.3 V	97	
battery backup	97	
Program Mode	37	
switching modes	37	
programming cable			
PROG connector	37	
RCM4510W connections	12	
programming port	36	
Prototyping Board	84	
access to RCM4510W analog inputs	86	
adding components	91	
dimensions	87	
expansion area	85	
features	84, 85	
jumper configurations	94	
jumper locations	94	
mounting RCM4510W	11	
pinout	89	
power supply	88	
prototyping area	90	
specifications	88	
use of Rabbit 4000 signals	90	
R			
Rabbit 4000			
spectrum spreader time delays	79	
Rabbit subsystems	27	
RCM4510W			
mounting on Prototyping Board	11	
real-time clock			
battery backup	98	
Run Mode	37	
switching modes	37	
S			
sample programs	18, 59	
getting to know the RCM4510W			
CONTROLLED.C	18	
FLASHLED1.C	18	
FLASHLED2.C	18	
TAMPERDETECTION.C	19	
TOGGLESWITCH.C	19	
PONG.C	14	
real-time clock			
RTC_TEST.C	23	
SETRTCKB.C	23	
sample programs (continued)			
serial communication			
FLOWCONTROL.C	20	
IOCONFIG_SWITCHECHO.C	22	
PARITY.C	20	
SERDMA.C	20	
SIMPLE3WIRE.C	21	
SIMPLE5WIRE.C	21	
SWITCHCHAR.C	21	
sleep mode	66	
USERBLOCK_CLEAR.C	47	
USERBLOCK_INFO.C	47	
XBee RF module			
AT_INTERACTIVE.C	15, 62, 101, 105	
AT_RUNONCE.C	62	
MODEMFWLOAD.C	101, 102	
SLEEPMODE.C	63	
SLEEPMODE2.C	64	
XBEE_GPIO_SERVER.C	59, 64	
ZigBee setup	59	
serial communication	34	
function calls	47	
Prototyping Board			
RS-232	92	
software			
PACKET.LIB	47	
RS232.LIB	47	
serial ports	34	
programming port	36	
receive line not pulled up	35	
Serial Port B (XBee RF module)	34	
Serial Port E			
configuration information	22, 34	
Serial Port F			
configuration information	22, 34	
sleep mode	65	
sample programs	66	
ST setting	65	
xb_sleep()	65, 66	
xb_tick()	66	
zb_Rabbit_poweroff()	66	

software	6	T		Z	
external I/O bus	33, 47	technical support	16	ZigBee	
I/O drivers	47	U		software libraries	49
libraries		user block		ZigBee protocol	
RCM45xxW.LIB	52	determining size	47	coordinator	57
serial communication drivers		function calls	47	end device	57
.....	47	readUserBlock()	43	introduction	57
version compatibility	6	writeUserBlock()	43	mesh network	57
ZigBee drivers	49	reserved area for calibration		router	57
specifications		constants	47		
bus loading	77	X			
digital I/O buffer sourcing and		XBee firmware	6		
sinking limits	77	upgrading to ZB	58		
exclusion zone	71	ZB	6, 58		
header footprint	75	Znet 2.5	6, 58		
Prototyping Board	88	Znet 2.5 vs. ZB	58		
Rabbit 4000 DC characteris-					
tics	76				
Rabbit 4000 timing diagram					
.....	78				
RCM4510W	69				
dimensions	70				
electrical, mechanical, and					
environmental	72				
relative pin 1 locations	75				
XBee RF module	74				
spectrum spreader	79				
settings	42				
subsystems					
digital inputs and outputs ..	26				
switching modes	37				



SCHEMATICS

090-0242 RCM4500W Schematic (preview version)

www.rabbit.com/documentation/schemat/090-0242.pdf

090-0246 RCM4500W Schematic (standard release)

www.rabbit.com/documentation/schemat/090-0246.pdf

090-0230 Prototyping Board Schematic

www.rabbit.com/documentation/schemat/090-0230.pdf

090-0128 Programming Cable Schematic

www.rabbit.com/documentation/schemat/090-0128.pdf

090-0252 USB Programming Cable Schematic

www.rabbit.com/documentation/schemat/090-0252.pdf

You may use the URL information provided above to access the latest schematics directly.

