

2

1

Top View of Assembly

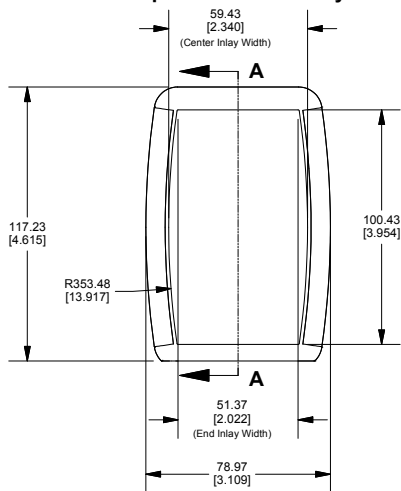

SECTION A-A (Side View Inside Assembly)

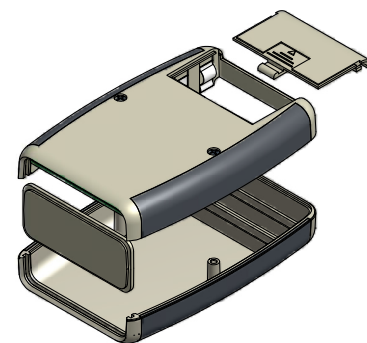
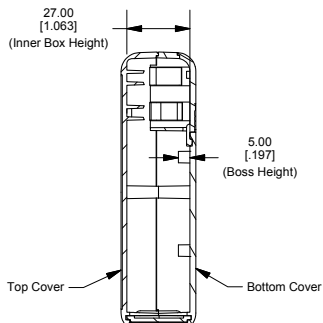

End View of Assembly

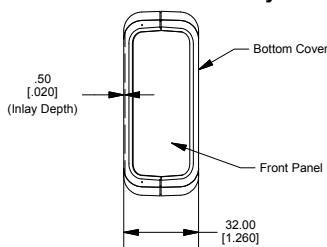

Inside of Bottom Cover

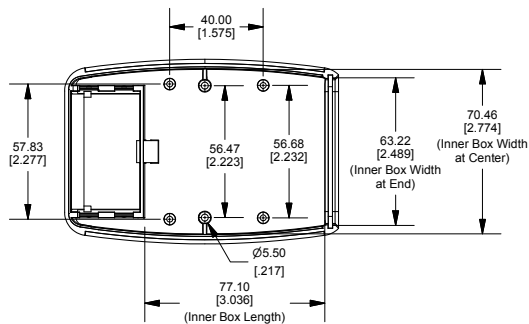

Front Panel

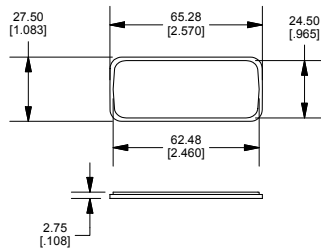

Maximum PCB Size

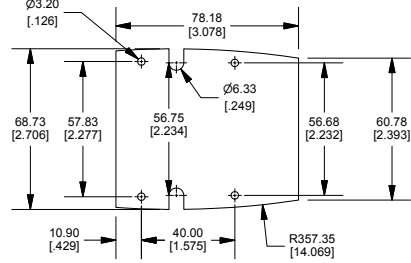

Enclosures can be Factory Modified (Milling, Drilling, Printing etc.)
Solid models of this enclosure available in STEP or IGES.
Contact Factory mjm@hammondmfg.com

NOTE	
Enclosure molded from GP ABS (UL94-HB) plastic.	
Purchased assembly includes top and bottom cover, front plastic panel, battery door, battery spring clips, 9V adapter and 4 cover screws.	

PART NUMBERS	
1553C Enclosure	
Black Enclosure/Grey Over-mold	1553CBKBAT
Grey Enclosure/Grey Over-mold	1553CGYBAT
ACCESSORIES	
Cover Screws (Pkg 100) [#4 x 1" self-tapping screw (25mm)]	Silver or Black
P.C. Board Screws [#4 x 1/4" self-tapping (6.4mm)]	1593ATS50 (Pkg 50) 1593ATS100 (Pkg 100)
Belt or Pocket Clip	1599CLIP (Black) 1599CLIPGY (Grey)

HAMMOND MANUFACTURING™
1553C-BAT
www.hammondmfg.com

2

1