

FEATURES AND SPECIFICATIONS

Features and Benefits

- Crimp wire sizes 18 to 26 AWG
- Patented double cantilever design
- Complete line of terminal crimping equipment available
- 2878 bifurcated terminal offers 2 points of contact for increased reliability

Reference Information

Packaging: Bag or reel
 UL File No.: E29179
 CSA File No.: LR19980
 Use With: 2574 housing
 Designed In: Inches

molex® 3.96mm (.156") Pitch KK® Single-Sided Terminals

2478/2578/2878

Electrical

Voltage: 250V
 Current: Use table

AWG	18	20	22	24	26
Phosphor Bronze (Amperes max.)	7.00	6.25	5.50	5.00	4.50
Brass (Amperes max.)	5.00	4.75	4.50	4.25	4.00

Contact Resistance: 20mΩ max.
 Dielectric Withstanding Voltage: 1500V
 Insulation Resistance: 50,000 MΩ min.

Mechanical

Contact Insertion Force: 1.36kg (3 lb) max.
 Contact Retention to Housing: 3.63kg (8 lb) min.
 when pulled in an axial direction
 Normal Force: 0.75kg (1.65 lb)

Physical

Contact: Brass/Phosphor Bronze
 Plating: See Table
 Temperature: 0 to +50°C

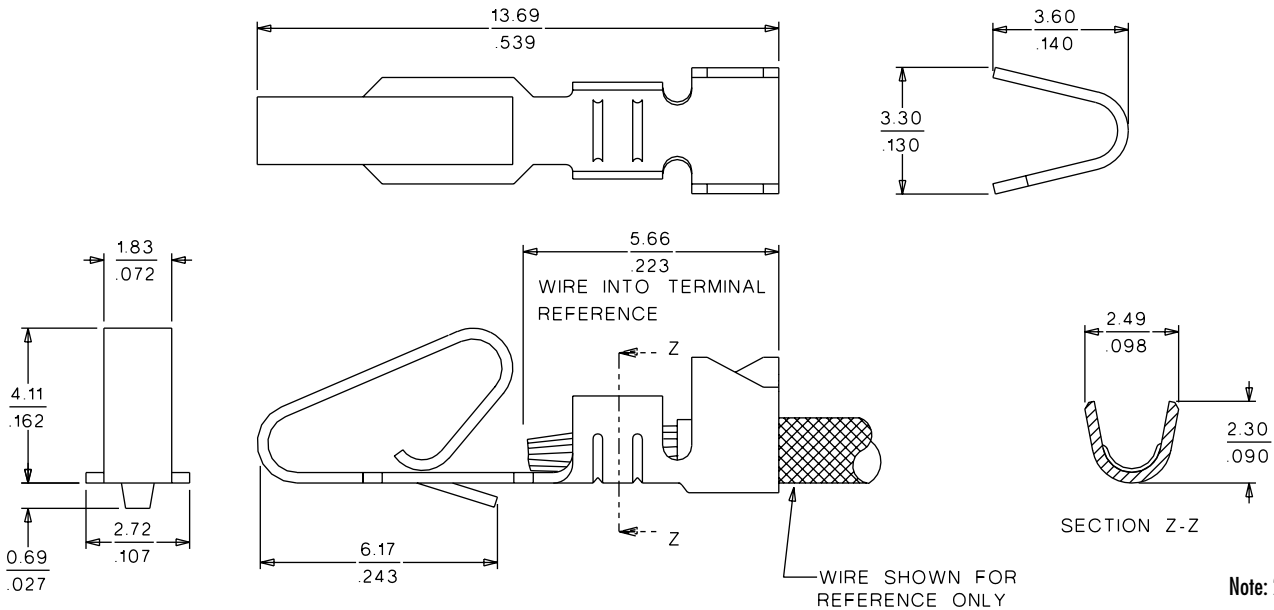
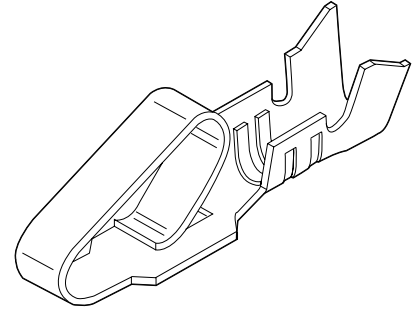

ORDERING INFORMATION AND DIMENSIONS

Wire Size	Maximum Insulation Outside Diameter	Series	Material	Tin Plating		Gold Plating No. 1		Gold Plating No. 2	
				Bag	Reel	Bag	Reel	Bag	Reel
18-20	2.79 (.110)	2478	Phosphor Bronze	• 08-52-0072	• 08-52-0071	• 08-58-0122	• 08-58-0121	• 08-65-0115	• 08-65-0114
18-20	2.79 (.110)	2478	Brass	08-50-0106	08-50-0105	08-56-0106	08-56-0105	08-55-0104	08-55-0103
18-20	2.79 (.110)	2878	Phosphor Bronze	• 08-52-0127	• 08-52-0126	• 08-58-0128	• 08-58-0127	• 08-65-0119	• 08-65-0118
18-20	2.79 (.110)	2878	Brass	08-50-0116	08-50-0115				
22-26	1.65 (.065)	2578	Phosphor Bronze	• 08-50-0134	• 08-50-0133	• 08-58-0126	• 08-58-0125	• 08-65-0117	• 08-65-0116
22-26	1.65 (.065)	2578	Brass	08-50-0108	08-50-0107	08-56-0108	08-56-0107	08-55-0106	08-55-0105

Terminal Engineering No.	Hand Tools		Crimp Machine	
	Crimping Order and Engineering No. (JHTR-2445-A)	Extraction Order and Engineering No. (HTA-2174)	Bench Order and Engineering No. (TM-40D)	Automatic Type
2478	11-01-0026	11-03-0016	11-04-0418	KM40S
2578(a)			11-04-0420	
2878			11-04-0418	

• US Standard Product, available through Molex franchised distributors
 Recommended wire range assumes stranded wire
 Plating No. 1: 20µ" min. Gold in contact area with a flash overall
 Plating No. 2: 15µ" min. Gold in contact area only