

NEC NEC LCD Technologies, Ltd.

INVERTER

104PW201

DATA SHEET

DOD-PP-0047 (1st edition)

**This DATA SHEET is updated document from
PRELIMINARY DATA SHEET DOD-PD-1322(1).**

**All information is subject to change without notice.
Please confirm the sales representative before
starting to design your system.**

INTRODUCTION

The Copyright to this document belongs to NEC LCD Technologies, Ltd. (hereinafter called "NEC"). No part of this document will be used, reproduced or copied without prior written consent of NEC.

NEC does and will not assume any liability for infringement of patents, copyrights or other intellectual property rights of any third party arising out of or in connection with application of the products described herein except for that directly attributable to mechanisms and workmanship thereof. No license, express or implied, is granted under any patent, copyright or other intellectual property right of NEC.

Some electronic parts/components would fail or malfunction at a certain rate. In spite of every effort to enhance reliability of products by NEC, the possibility of failures and malfunction might not be avoided entirely. To prevent the risks of damage to death, human bodily injury or other property arising out thereof or in connection therewith, each customer is required to take sufficient measures in its safety designs and plans including, but not limited to, redundant system, fire-containment and anti-failure.

The products are classified into three quality grades: "**Standard**", "**Special**", and "**Specific**" of the highest grade of a quality assurance program at the choice of a customer. Each quality grade is designed for applications described below. Any customer who intends to use a product for application other than that of Standard quality grade is required to contact an NEC sales representative in advance.

The **Standard** quality grade applies to the products developed, designed and manufactured in accordance with the NEC standard quality assurance program, which are designed for such application as any failure or malfunction of the products (sets) or parts/components incorporated therein a customer uses are, directly or indirectly, free of any damage to death, human bodily injury or other property, like general electronic devices.

Examples: Computers, office automation equipment, communications equipment, test and measurement equipment, audio and visual equipment, home electronic appliances, machine tools, personal electronic equipment, industrial robots, etc.

The **Special** quality grade applies to the products developed, designed and manufactured in accordance with an NEC quality assurance program stricter than the standard one, which are designed for such application as any failure or malfunction of the products (sets) or parts/components incorporated therein a customer uses might directly cause any damage to death, human bodily injury or other property, or such application under more severe condition than that defined in the Standard quality grade without such direct damage.

Examples: Control systems for transportation equipment (automobiles, trains, ships, etc.), traffic control systems, anti-disaster systems, anti-crime systems, medical equipment not specifically designed for life support, safety equipment, etc.

The **Specific** quality grade applies to the products developed, designed and manufactured in accordance with the standards or quality assurance program designated by a customer who requires an extremely higher level of reliability and quality for such products.

Examples: Military systems, aircraft control equipment, aerospace equipment, nuclear reactor control systems, medical equipment/devices/systems for life support, etc.

The quality grade of this product is the "**Standard**" unless otherwise specified in this document.

CONTENTS

INTRODUCTION 2

1. OUTLINE..... 4

2. SPECIFICATIONS..... 4

 2.1 GENERAL SPECIFICATIONS..... 4

 2.2 ABSOLUTE MAXIMUM RATINGS 4

 2.3 ELECTRICAL CHARACTERISTICS 5

 2.4. FUSE..... 5

 2.5 CONNECTIONS AND FUNCTIONS FOR INTERFACE PINS..... 6

 2.6 LUMINANCE CONTROL..... 7

3. RELIABILITY TEST..... 7

4. PRECAUTIONS 8

 4.1 MEANING OF CAUTION SIGNS 8

 4.2 CAUTIONS 8

 4.3 ATTENTIONS 8

 4.3.1 Handling of the product 8

 4.3.2 Environment..... 9

 4.3.3 Other 9

5. OUTLINE DRAWINGS 10

1. OUTLINE

This 104PW201 inverter is for LCD module. Adaptable LCD modules are as follows.

Adaptable LCD modules
NL6448BC33-63D
NL6448BC33-64

2. SPECIFICATIONS

2.1 GENERAL SPECIFICATIONS

Item	Specification	Unit
Size	See "5. OUTLINE DRAWINGS".	mm
Weight	23 (max.)	g
Delivery unit	10 (min.)	set

☆

2.2 ABSOLUTE MAXIMUM RATINGS

Parameter	Symbol	Rating	Unit	Remarks
Power supply voltage	VDDDB	0 to +14.0	V	-
Input voltage	BRTC signal VBC	-1.0 to VDDDB+1.0	V	
	BRTI signal VBI	-1.0 to +5.0	V	
Storage temperature	Tst	-30 to +85	°C	-
Operating temperature	Top	-30 to +70	°C	-
Relative humidity Note1	RH	≤ 95	%	Ta ≤ 40°C
		≤ 85	%	40 < Ta ≤ 50°C
		≤ 55	%	50 < Ta ≤ 60°C
		≤ 36	%	60 < Ta ≤ 70°C
Absolute humidity Note1	AH	≤ 70 Note2	g/m ³	Ta > 70°C

☆

☆

☆

Note1: No condensation

Note2: Water amount at Ta = 70°C and RH = 36%

2.3 ELECTRICAL CHARACTERISTICS

(Ta = 25°C)

Parameter			Symbol	min.	typ.	max.	Unit	Remarks
Power supply voltage			VDDB	10.8	12.0	13.2	V	Note1, Note2
Power supply current			IDDB	-	530	600	mA	(at the maximum luminance control.) Note2
Input voltage	BRTC signal	High	VBCH	2.0	-	VDDB	V	-
		Low	VBCL	0	-	0.8	V	
	BRTI signal		VBI	0	-	2.5	V	
Input current	BRTC signal	High	IBCH	-	-	1,670	μA	-
		Low	IBCL	-170	-	-	μA	
	BRTI signal		IBI	-670	-	-350	μA	
Output voltage	Open lamp voltage		VO	1,750	-	-	Vrms	Ta = -20 to +70
	Lamp voltage (at steady state)		VLH	-	520	-	Vrms	-
	AM signal	High	VAMH	4.5	5.0	5.5	V	at malfunction
		Low	VAML	-	-	0.5	V	at normal
Output current	Lamp current (per lamp)		IBL	4.5	5.0	5.5	mArms	at the maximum luminance control
Oscillation frequency			FO	63.5	67.5	72.0	kHz	-
Luminance control frequency			FB	241	255	268	Hz	

Note1: When designing of the power supply, take the measures for the prevention of surge voltage.

Note2: The power supply lines (VDDB and GNDB) have large ripple voltage during luminance control of LCD lamps. There is the possibility that the ripple voltage produces acoustic noise and signal wave noise in audio circuit and so on. Put a capacitor (5,000 to 6,000μF) between the power supply lines (VDDB and GNDB) to reduce the noise, if the noise occurred in the circuit.

2.4. FUSE

Parameter	Fuse		Rating	Fusing current	Remarks
	Type	Supplier			
VDDB	CCP2E20HTTE	KOA Corporation	1.0A	2.0A	Note1
			72V		

Note1: The power supply capacity should be more than the fusing current. If it is less than the fusing current, the fuse may not blow in a short time, and then nasty smell, smoke and so on may occur.

2.5 CONNECTIONS AND FUNCTIONS FOR INTERFACE PINS

CN1 socket (Inverter side): 53261-0871 (MOLEX Inc.)
 Adaptable plug: 51021-0800 (MOLEX Inc.)

Pin No.	Symbol	Function	Remarks
1	VDDB	Power supply	Note1
2	VDDB	Power supply	
3	GNDB	Ground	
4	GNDB	Ground	
5	BRTC	Backlight ON/OFF signal	High or Open: Backlight ON Low: Backlight OFF This pin is pulled-up to VDDB in the product. Pull-up resistance: 100 kΩ ☆
6	BRTI	Luminance control terminal	Note2
7	BRTH	Luminance control terminal	
8	AM	Alert signal for malfunction	Note3

Note1: All GNDB and VDDB terminals should be used without any non-connected lines.

Note2: See "2.6 LUMINANCE CONTROL".

Note3: If anyone of terminals Pin No.1, 2 or 4 (CN2) opens or shorts, then the alert signal (+5.0V typ.) is output. ☆

CN2 socket (Inverter side): SM03 (7-D1) B-BHS-1-TB(LF)(SN) (J.S.T. Mfg Co., Ltd.)
 Adaptable plug (Backlight side): BHR-04VS-1 (J.S.T. Mfg Co., Ltd.)

Pin No.	Symbol	Signal	Remarks
1	VBLH	High voltage (Hot)	-
2	VBLH	High voltage (Hot)	-
3	N. C.	-	Keep this pin Open.
4	VBLC	Low voltage (Cold)	-

Note1: VBLH and VBLC must be connected correctly. Wrong connections will cause electric shock and also break down of the product.

2.6 LUMINANCE CONTROL

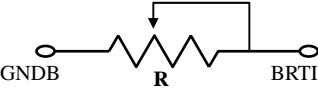
Method	Adjustment and luminance ratio						
Resistor control	<ul style="list-style-type: none"> • Adjustment The variable resistor (R) for luminance control should be 10kΩ ±5%, 1/10W. Minimum point of the resistor is the minimum luminance. Also maximum point of the resistor is the maximum luminance. The resistor (R) must be connected between BRTH-BRTI terminals.  <ul style="list-style-type: none"> • Luminance ratio Note1 <table border="1" data-bbox="539 779 1369 913"> <thead> <tr> <th>Resistance</th> <th>Luminance ratio</th> </tr> </thead> <tbody> <tr> <td>0Ω</td> <td>20% (Min. Luminance)</td> </tr> <tr> <td>10kΩ</td> <td>100% (Max. Luminance)</td> </tr> </tbody> </table>	Resistance	Luminance ratio	0Ω	20% (Min. Luminance)	10kΩ	100% (Max. Luminance)
Resistance	Luminance ratio						
0Ω	20% (Min. Luminance)						
10kΩ	100% (Max. Luminance)						
Voltage control	<ul style="list-style-type: none"> • Adjustment Voltage control method works, when BRTH terminal is 0V and VBI voltage is input between BRTI and BRTH terminal. This control method can carry out continuation adjustment of luminance. Luminance is the maximum when BRTI terminal is Open. <ul style="list-style-type: none"> • Luminance ratio Note1 <table border="1" data-bbox="539 1182 1369 1317"> <thead> <tr> <th>BRTI signal (VBI)</th> <th>Luminance ratio</th> </tr> </thead> <tbody> <tr> <td>0V</td> <td>20% (Min. Luminance)</td> </tr> <tr> <td>2.5V</td> <td>100% (Max. Luminance)</td> </tr> </tbody> </table>	BRTI signal (VBI)	Luminance ratio	0V	20% (Min. Luminance)	2.5V	100% (Max. Luminance)
BRTI signal (VBI)	Luminance ratio						
0V	20% (Min. Luminance)						
2.5V	100% (Max. Luminance)						

Note1: These data are the target values.

☆

☆

3. RELIABILITY TEST

This test is in accordance with the Reliability Test of the adaptable LCD module. Refer to Reliability Test of the adaptable LCD module.

4. PRECAUTIONS

4.1 MEANING OF CAUTION SIGNS

The following caution signs have very important meaning. **Be sure to read "4.2 CAUTIONS" and "4.3 ATTENTIONS", after understanding these contents!**

	This sign has the meaning that customer will be injured by himself or the product will sustain a damage, if customer has wrong operations.
---	--

	This sign has the meaning that customer will get an electrical shock, if customer has wrong operations.
---	---

	This sign has the meaning that customer will be injured by himself, if customer has wrong operations.
---	---

4.2 CAUTIONS

	<ul style="list-style-type: none"> * Do not touch the inverter while the inverter is working, because there is a danger of an electric shock. * Do not remove the inverter protection sheet, because there is a danger of an electrical shock. * Be sure to wait some time after turning power OFF before starting replacement work, because the inverter is charged at a high voltage after working.
--	---

	<ul style="list-style-type: none"> * Be sure to wait some time after turning power OFF before starting replacement work, because the inverter is hot after working. * Do not shock the inverter, because there is a danger of breaking.
---	---

4.3 ATTENTIONS



4.3.1 Handling of the product

- ① Take hold of both ends without touching the circuit board when the product (INVERTER) is picked up from inner packing box to avoid broken down or misadjustment, because of stress to mounting parts on the circuit board.
- ② When handling the product, take the measures of electrostatic discharge with such as earth band, ionic shower and so on, because the product may be damaged by electrostatic.
- ③ Do not push nor pull the interface connectors while the product is working.
- ④ Do not hook nor pull cables such as lamp cable, and so on, in order to avoid any damage.
- ⑤ Properly connect the adaptable plug (backlight side) to socket (inverter side) without incomplete connection. After connecting, be careful not to hook the lamp cables because incomplete connection may occur by hooking the lamp cables. This incomplete connection may cause abnormal operation of high voltage circuit.

4.3.2 Environment

- ① Do not operate or store in high temperature, high humidity, dewdrop atmosphere or corrosive gases. Keep the product in packing box with antistatic pouch in room temperature to avoid dusts and sunlight, when storing the product.
- ② In order to prevent dew condensation occurring by temperature difference, the product packing box should be opened after enough time being left under the environment of an unpacking room. Evaluate the leaving time sufficiently because a situation of dew condensation occurring is changed by the environmental temperature and humidity. (Recommended leaving time: 6 hours or more with packing state)
- ③ Do not operate in high magnetic field. Circuit boards may be broken down by it.
- ④ This product is not designed as radiation hardened.

4.3.3 Other

- ① All GNDB and VDDB terminals should be used without any non-connected lines.
- ② Do not disassemble a product.
- ③ Pack the product with original shipping package, in order to avoid any damages during transportation, when returning the product to NEC.
- ④ Put the spacer between inverter board and mounting surface, because of the protection for contortion and the preservation of spacial distance. ☆

Mounting method example 1.

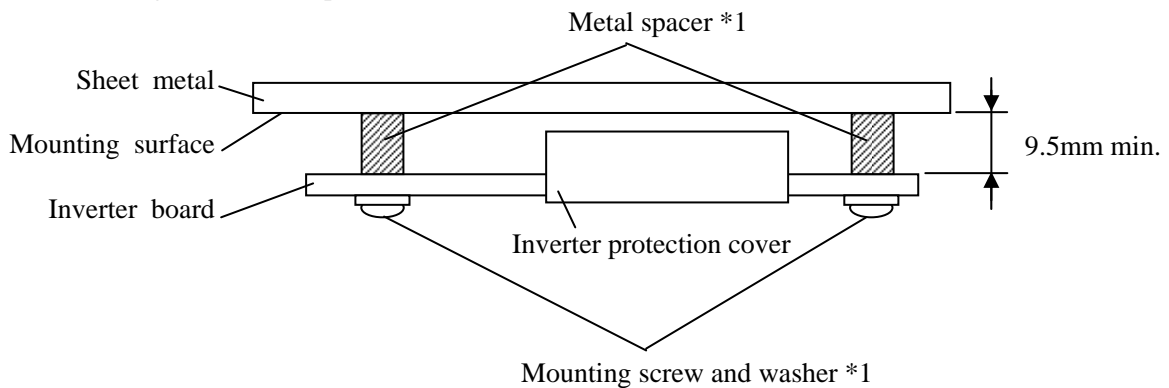

Mounting method example 2.

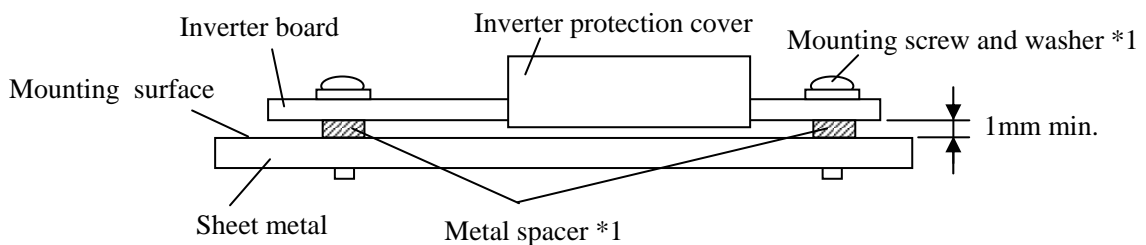

*1: The conductive material (mounting screw, washer, metal spacer and so on) is allowed to mount within the limits of 3.5mm radius from the center of mounting hole.

5. OUTLINE DRAWINGS

(Unit: mm)

☆

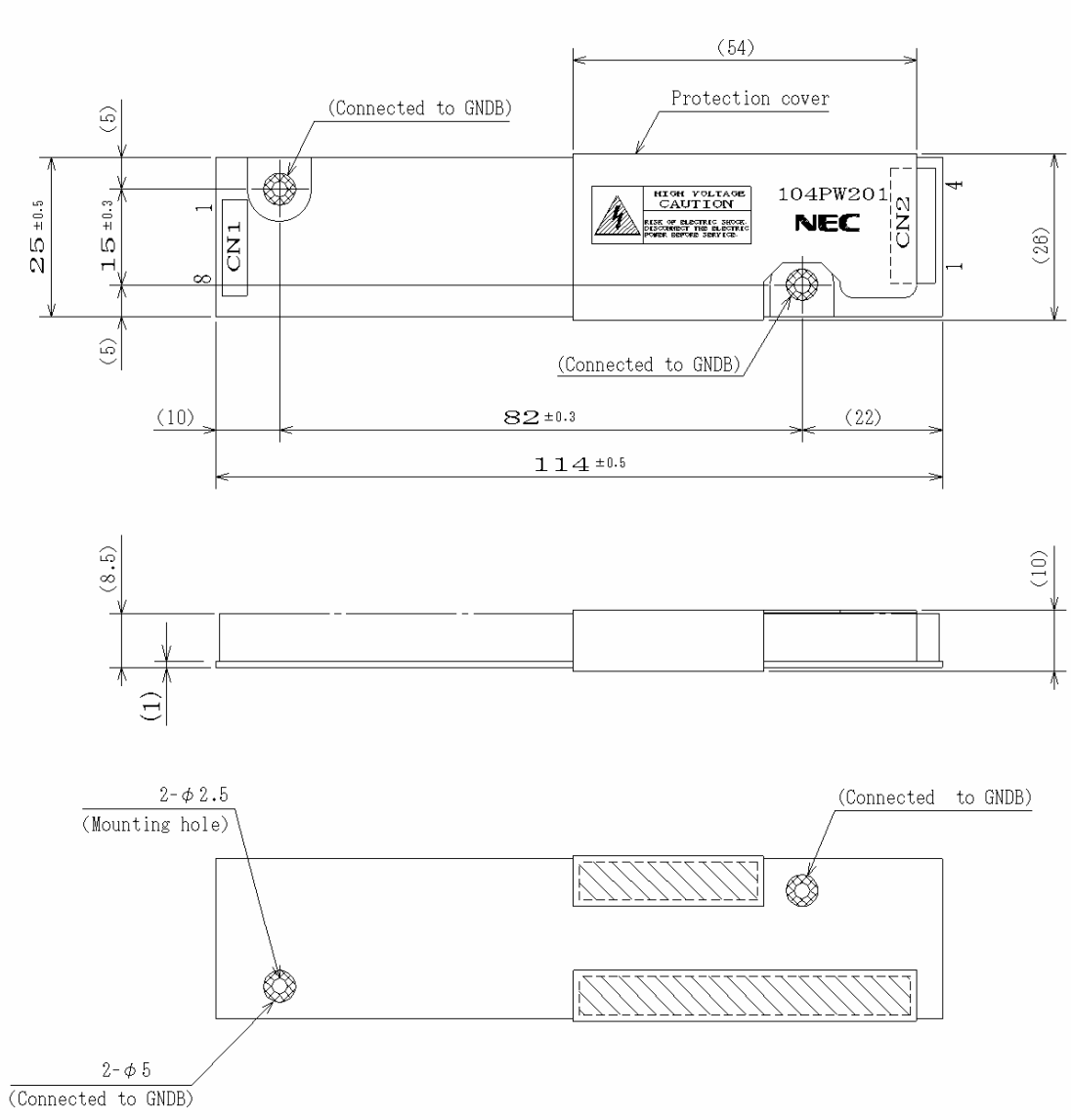

Note1: The values in parentheses are for reference.