

P.C. MOUNTING

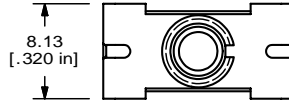

SWITCH FUNCTION		
POS. 1	POS. 1	POS. 1
ON	NONE	ON
2-3	OPEN	2-1

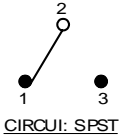

- NOTE:
- ALL DIMENSIONS IN MM [INCH]
  - GENERAL TOLERANCE: X.X=±0.4  
X.XX=±0.25
  - TERMINAL NUMBERS FOR REF ONLY
  - PLATING MATERIAL: SILVER
  - RATING: 5 AMPS W/RESISTIVE LOAD @ 120VAC OR 28VDC  
2 AMPS W/RESISTIVE LOAD @ 250VAC
  - ELECTRIC LIFE: 40,000 make-and-break cycles at full load.
  - INSULATION RESISTANCE: 1,000 Mega-ohm min.
  - DIELECTRIC STRENGTH: 1,000 V RMS @sea level.
  - OPERATING TEMP.: -30° C to 85° C
  - ▲ DENOTES CRITICAL PARAMETER.
  - 2002/95/EC (ROHS) COMPLIANT
  - HARDWARE TO BE SUPPLIED BULK:  
T100011-LOCK WASHER QTY-1  
T100015-LOCK RING QTY-1  
T100000-HEX NUT QTY-2

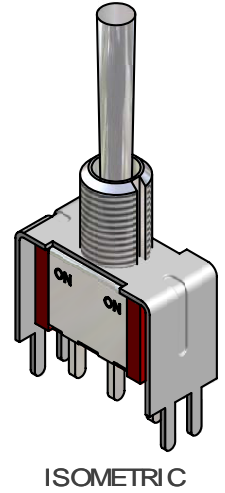
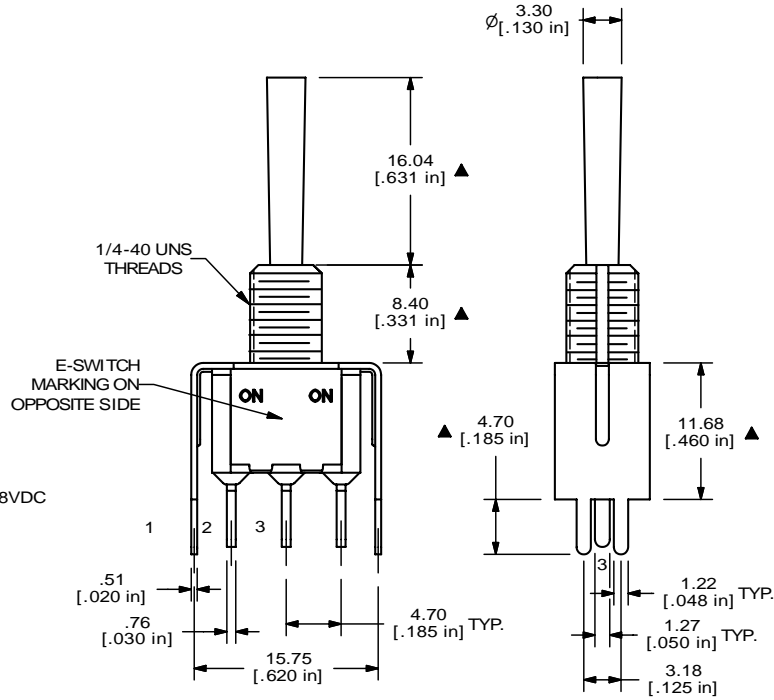

**E-SWITCH®**

B	15790	EDIT TOGGLE DIA.	2/17/06	PH
A	15517	RELEASE	11/9/05	PH
REV	PCR NO	DESCRIPTION	DATE	BY

TITLE 100SP1T4B1VS2QE#				
SCALE 2:1	DATE 9/11/2005	DR PH	DWG ST111039	REV B

THE INFORMATION CONTAINED IN THIS DOCUMENT IS PROPRIETARY TO E-SWITCH AND IS NOT TO BE COPIED OR TRANSFERRED