

SPDT CIRCUIT
CONTACT CONFIGURATION

SWITCH FUNCTION		
POS. 1	POS. 2	POS. 3
DN	NDNE	DN
2-3	OPEN	2-1

NOTES:

1. ALL DIMENSIONS IN MM [INCH]
 2. GENERAL TOLERANCE: X.X=±0.4 X:XX=±0.25
 3. TERMINAL NUMBERS FOR REF ONLY
 4. RATING: 5A @120VAC OR 28VDC: 2A @250VAC
 5. FIXED TERM. & MOVING CONTACT: Cu Alloy w/ Silver plate.
 6. ELECTRIC LIFE: 50,000 make-and-break cycles at full load.
 7. INSULATION RESISTANCE: 1,000 Mega-ohm min.
 8. DIELECTRIC STRENGTH: 1,000 V RMS @sea level.
 9. OPERATING TEMP.: -30°C to +85°C
 10. 2002/95/EC (ROHS) COMPLIANT
 11. SUPPLIED HARDWARE: TO BE SHIPPED BULK
- T100011-LOCK WASHER QTY.1
T100015-LOCK RING QTY.1
T100000-HEX NUT QTY. 2

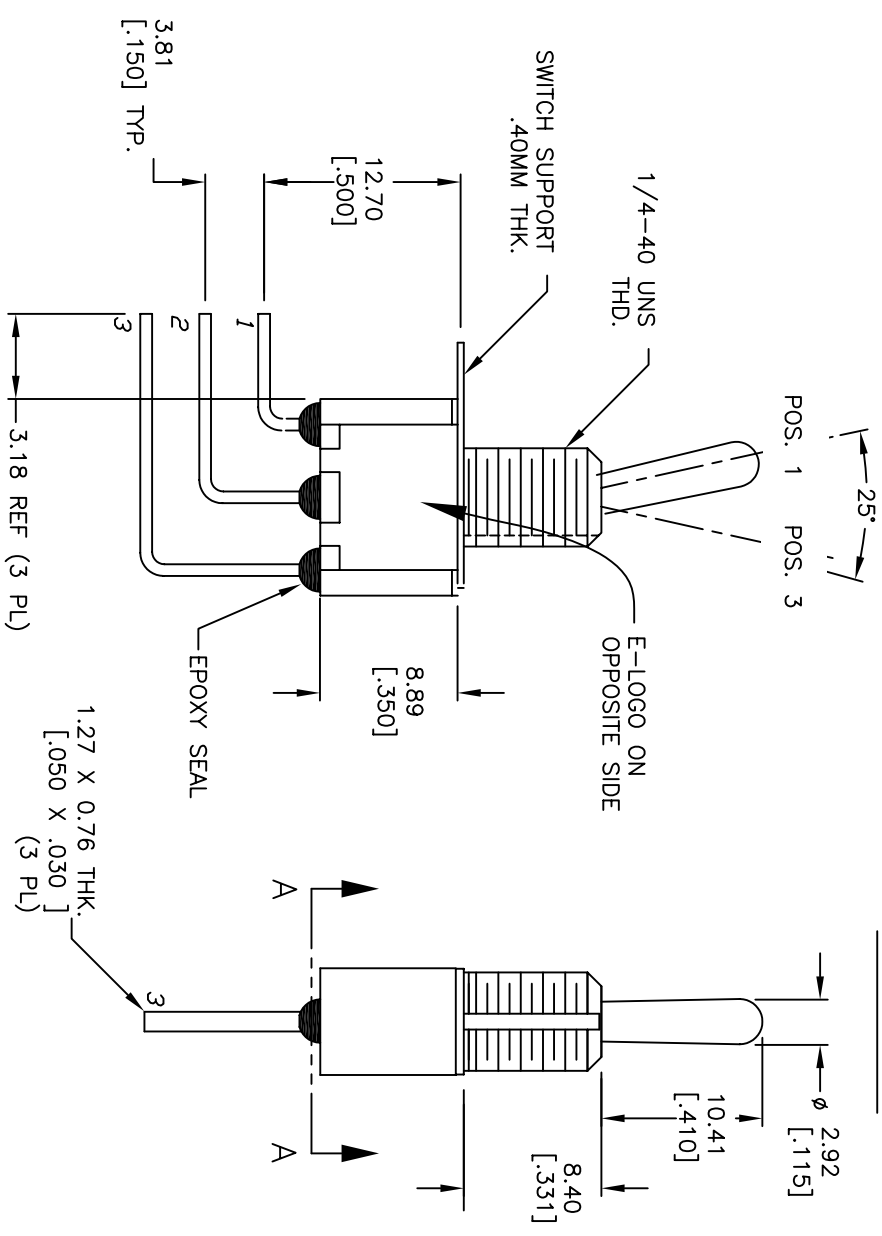
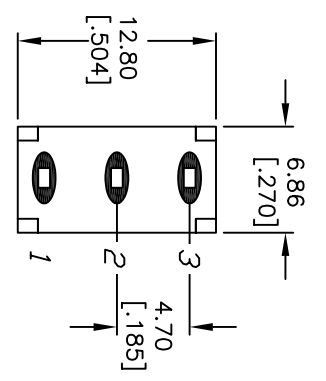
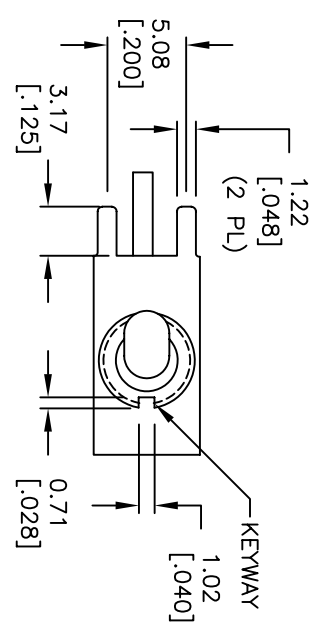

REV.	ECN No.	DESCRIPTION	DATE	CHKD
C	15593	DIM TD 8.40 FROM 8.89	12/7/05	PH
B	15468	DIM FROM 4.5 TO 3.18, ADD RSHS	10/28/05	PH
A	15465	RELEASED	10/27/05	PH

TITLE		SCALE	DATE	DR	DWG	REV
100 SP-1 T1 B1 M7 Q EH		2:1	10/27/05	PH	ST111010	C

