

SHEET OF

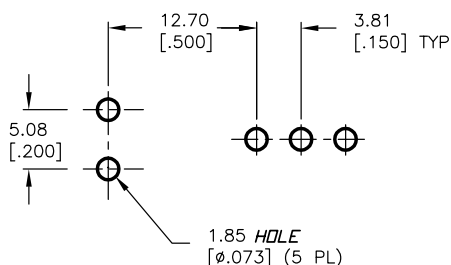

RECOMMENDED PCB LAYOUT



SPDT CIRCUIT CONTACT CONFIGURATION

SWITCH FUNCTION		
POS. 1	POS. 2	POS. 3
ON	OFF	ON
2-3	OPEN	2-1

NOTES:

1. ALL DIMENSIONS IN MM [INCH]
2. GENERAL TOLERANCE: X.X=±0.4
X.XX=±0.25
3. TERMINAL NUMBERS FOR REF ONLY
4. RATING: 0.4(VA) Max. @20V (AC or DC)
5. FIXED TERM. & MOVING CONTACT: Cu Alloy w/Gold plate over Ni plate.
6. ELECTRIC LIFE: 50,000 make-and-break cycles at full load.
7. INSULATION RESISTANCE: 1,000 Mega-ohm min.
8. DIELECTRIC STRENGTH: 1,000 V RMS @sea level.
9. OPERATING TEMP.: -30°C to 85°C

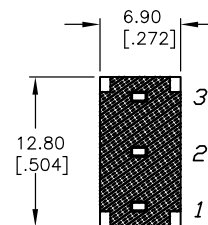
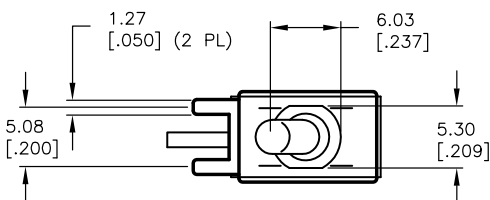

SECTION A-A

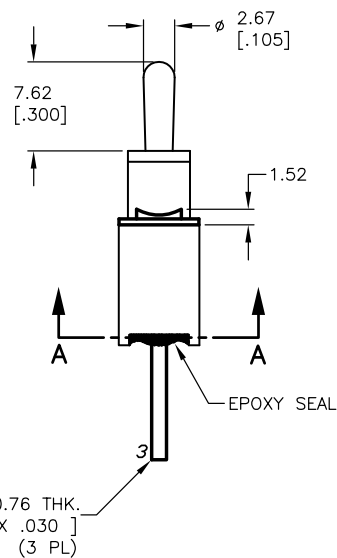
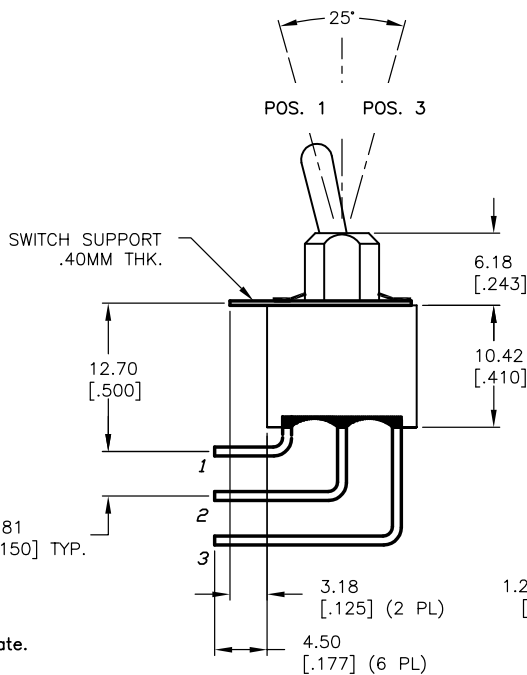

E-SWITCH®

TITLE		100AWSP3T2B4M7RE			
SCALE	DATE	DR	DWG	REV	
2:1	11/19/03	AR	T102303	A	

A	13614	RELEASED FOR PRODUCTION	11/19/03	AR
REV.	ECN No.	DESCRIPTION	DATE	CHKD
THE INFORMATION CONTAINED IN THIS DOCUMENT IS PROPRIETARY TO E-SWITCH AND IS NOT TO BE COPIED OR TRANSFERRED				