

Tous droits strictement réservés. Reproduction ou utilisation sans autorisation écrite du propriétaire. Propriété de c FCI. Droits de reproduction FCI.

All rights strictly reserved. Reproduction or use without permission without written authority from the proprietor. Property of FCI. Copyright FCI.

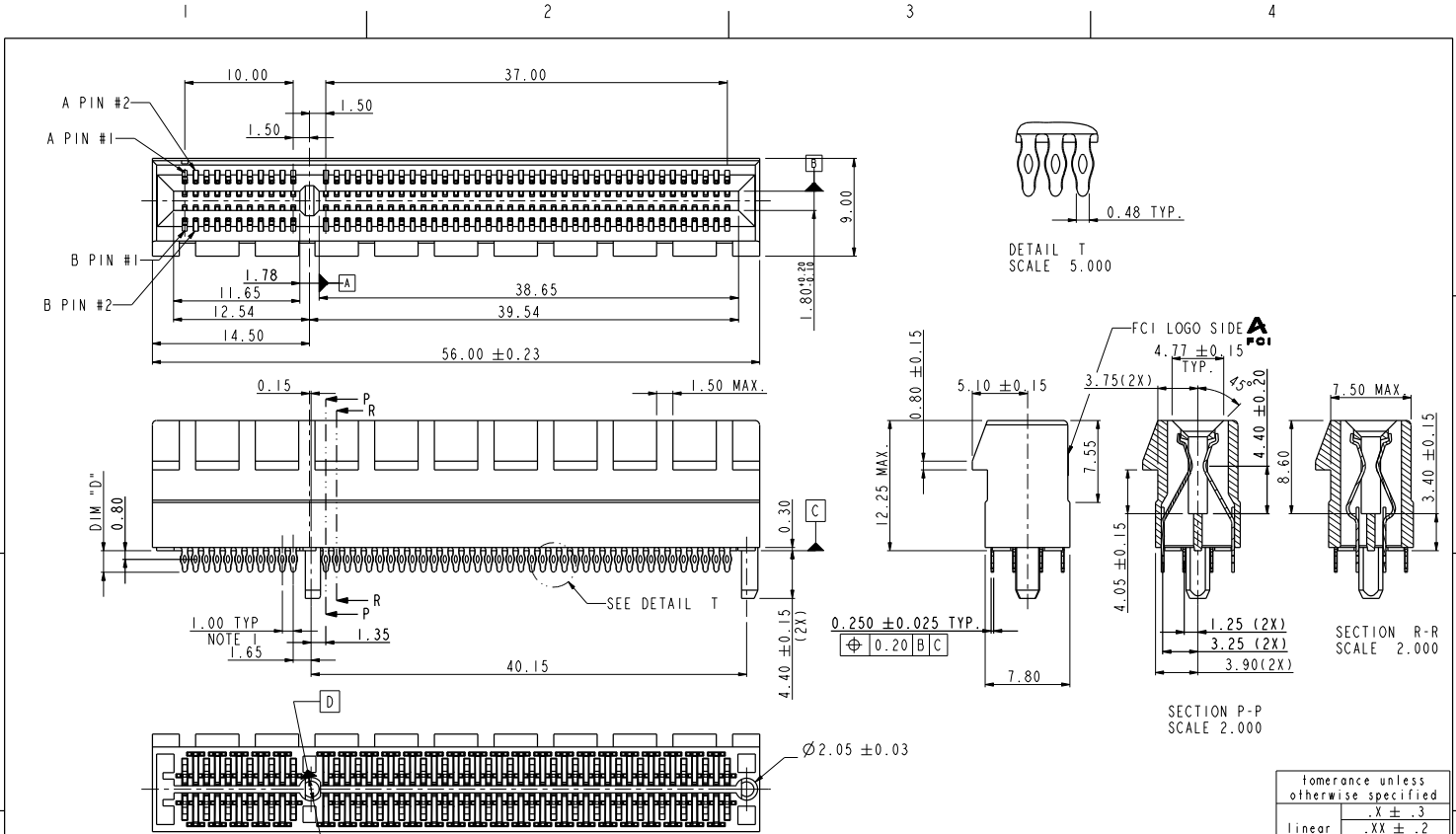

tolerance unless otherwise specified	
linear	.X ± .3 .XX ± .2 .XXX ± .1
angles	0° ± 2°

FCI www.fciconnect.com	tolerance	projection	size	Scale
Dr MAGGIE WU 04/20/05 Product family	✓	⊕	A4	1.000
Eng R Y LIU 04/20/05 Spec ref			ECN	DG06-0249
Chr PAUL WANG 04/20/05 Material				
Appr JOSEPH HSIA 04/20/05				
Title PCI Express ExpressModule CARD EDGE 98P PRESS-FIT ASS'Y		dwg no	10055293	Rev. F
catalog no	PDM: Rev:F	CUSTOMER DRAWING		sheet 1 of 5
	STATUS: Released	Printed: Nov 11, 2010		

rev	ecr no	dr	date
A	105-0236	M W	10/28/05
B	105-0243	M W	10/27/05
C	105-0257	M W	11/08/05
D	105-0267	M W	12/19/05
E	DG06-0161	P W	04/11/06
F	DG06-0249	P W	07/03/06

Tous droits strictement réservés. Reproduction ou utilisation sans autorisation écrite du propriétaire. Propriété de c FCI. Droits de reproduction FCI.

All rights strictly reserved. Reproduction or use without written permission is prohibited without written authority from the proprietor. Property of FCI. Copyright FCI.

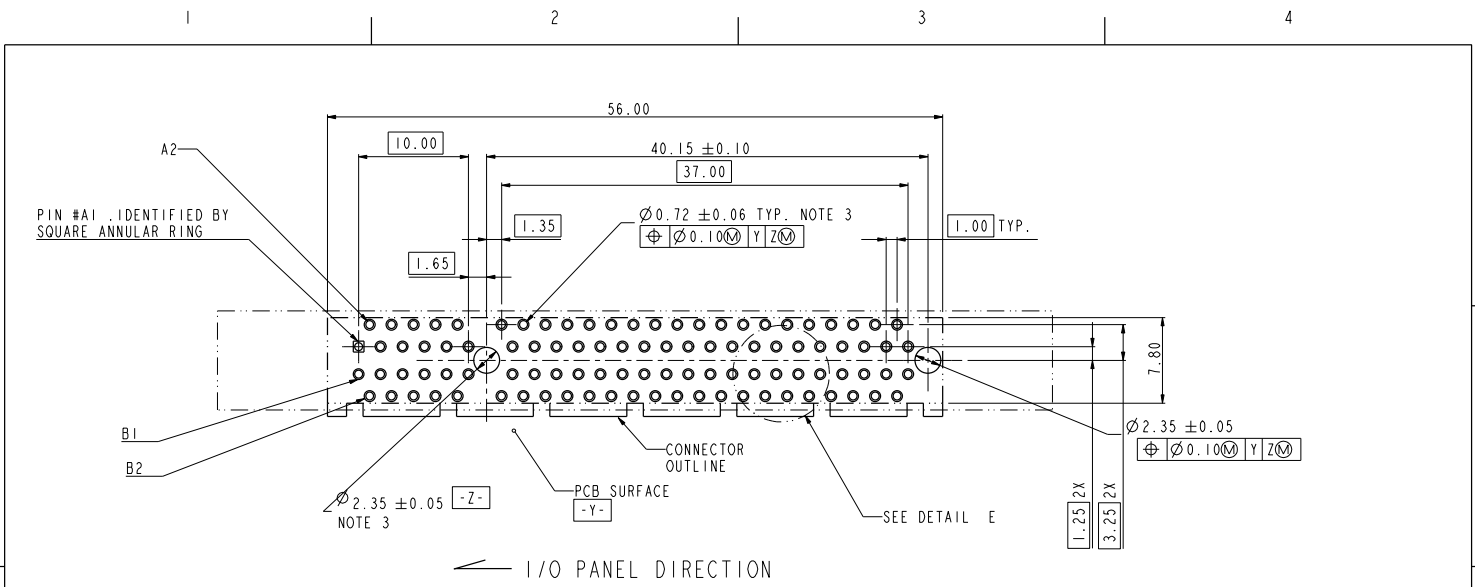

← I/O PANEL DIRECTION

RECOMMENDED FOOTPRINT

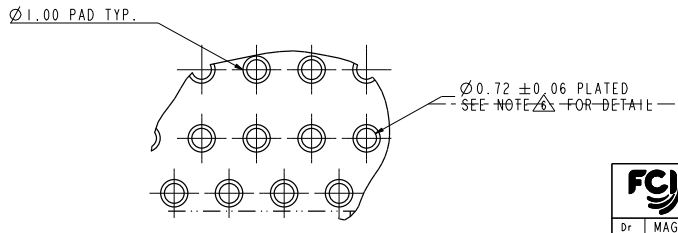

DETAIL E
SCALE 5.000

tolerance unless otherwise specified	
linear	.X ± .3 .XX ± .2 .XXX ± .1
angles	0° ± 2°

FCI www.fciconnect.com		tolerance	projection	size	Scale
Dr	MAGGIE WU	04/20/05	Product family	A4	1.000
Eng	R Y LIU	04/20/05	Spec ref	ECN	DG06-0249
Chr	PAUL WANG	04/20/05	Material		
Appr	JOSEPH HSIA	04/20/05			
Title			Part no	Rev.	
PCI Express ExpressModule CARD EDGE 98P PRESS-FIT ASS'Y			10055293	F	
catalog no		CUSTOMER DRAWING		sheet 2 of 5	

PDM-Rev:F STATUS:Released Printed: Nov 14, 2010

Tous droits strictement réservés. Reproduction ou utilisation sans autorisation écrite du propriétaire. Propriété de c FCI. Droits de reproduction FCI.

All rights strictly reserved. Reproduction or use without permission without written authority from the proprietor. Property of FCI. Copyright FCI.

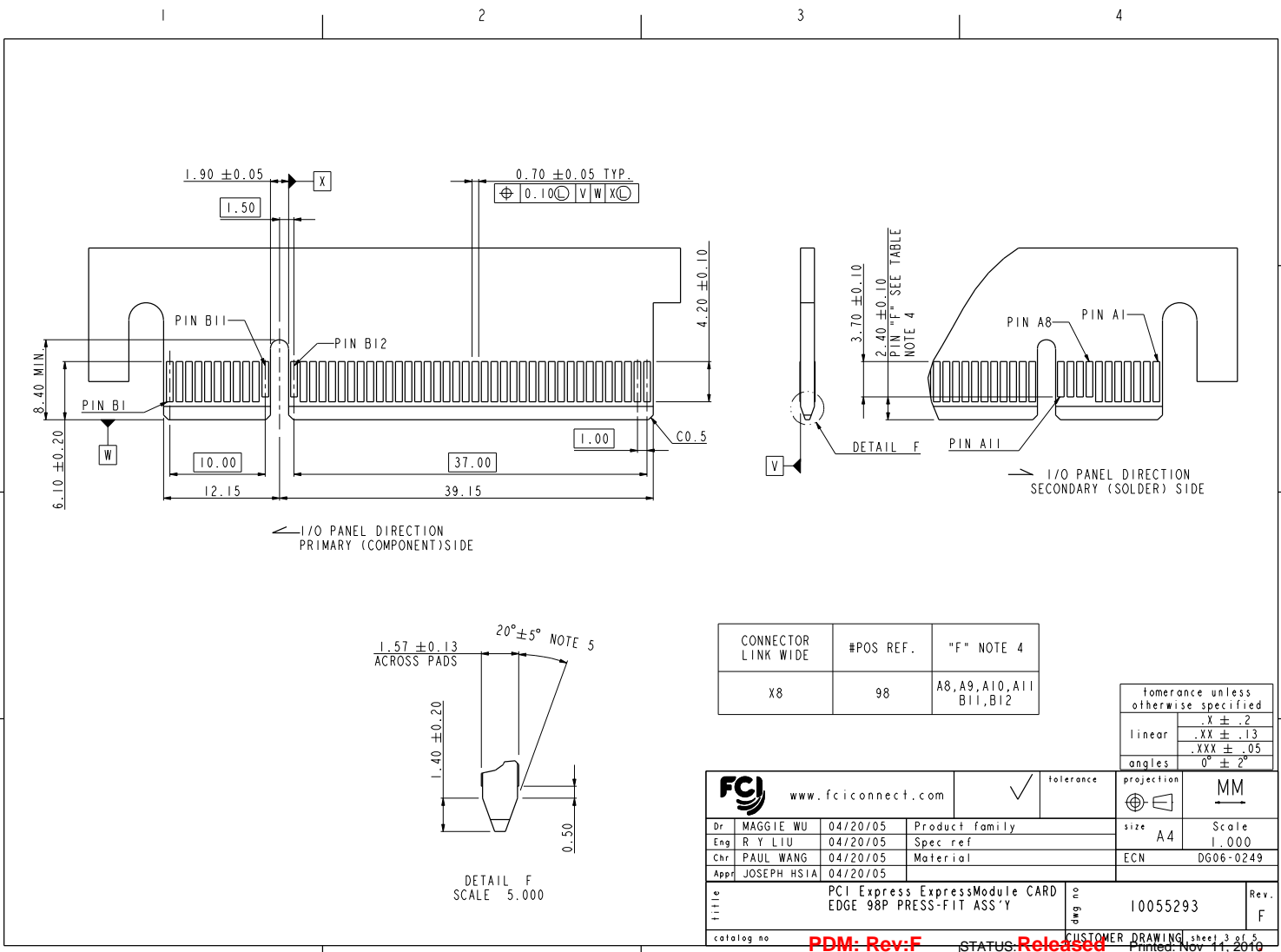

CONNECTOR LINK WIDE	#POS REF.	"F" NOTE 4
X8	98	A8, A9, A10, A11 B11, B12

tolerance unless otherwise specified	
linear	.X ± .2 .XX ± .13 .XXX ± .05
angles	0° ± 2°

FCI www.fciconnect.com		tolerance	projection	size	Scale
Dr	MAGGIE WU	04/20/05	Product family	A4	1.000
Eng	R Y LIU	04/20/05	Spec ref	ECN	DG06-0249
Chr	PAUL WANG	04/20/05	Material		
Appr	JOSEPH HSIA	04/20/05			
Title			Part no	Rev.	
PCI Express ExpressModule CARD EDGE 98P PRESS-FIT ASS'Y			10055293	F	
catalog no			CUSTOMER DRAWING	sheet 3 of 5	

PDM: Rev:F STATUS:Released Printed: Nov 11, 2010

Tous droits strictement réservés. Reproduction ou utilisation sans autorisation écrite du propriétaire. Propriété de c FCI. Droits de reproduction FCI.

All rights strictly reserved. Reproduction or use without permission without written authority from the proprietor. Property of FCI. Copyright FCI.

1 2 3 4

NOTES:

- MATERIAL:
HOUSING: HIGH TEMPERATURE NYLON, GLASS FILLED UL94V-0 RATED. SUITABLE FOR REFLOW SOLDERING.
TERMINAL: COPPER ALLOY
PLATING: 50u" NICKEL UNDERPLATE ALL OVER
CONTACT AREA PLATING - SEE PRODUCT NUMBER CODE
SOLDER TAIL: TIN - 100u" MIN. OVER 50u" NICKEL OR TIN/LEAD 100u" MIN. SEE PRODUCT NUMBER CODE
- PRODUCT SPECIFICATION: GS-12-319
 - THE HORIZONTAL AXIS FOR THE HOLE PATTERN IS ESTABLISHED BY A LINE THROUGH THE CENTER OF THE TWO Ø2.35 HOLES.
 - THE VERTICAL AXIS IS 90° TO THE HORIZONTAL AXIS, THROUGH THE CENTER OF DATUM Z.
 - NO TIE BAR PERMITTED FROM CARD EDGE TO LEADING EDGE OF PAD FOR PINS A1 AND PIN NUMBERS "F".
 - CHAMFER EDGES MUST BE FREE OF CUTTING BURRS.
 - ALL PLATED THRU HOLES SHOULD BE 0.76-0.83 mm DIA DRILLED AND 0.025mm ~ 0.05mm.
 - ELECTRO-DEPOSITED COPPER THK ON THROUGH HOLE WALL.
- RoHS COMPATIBLE PRODUCT SPECIFICATIONS
 - PLATING:
 - "LF" MEANS THE PRODUCT IS LEAD-FREE, 2um MINIMUM MATTE TIN OVER 1.27um MINIMUM NICKEL UNDERPLATE.
 - MANUFACTURING PROCESS COMPATIBILITY
 - THE HOUSING WILL WITHSTAND EXPOSURE TO 260°C±5°C SOLDER BATH TEMPERATURE FOR 10 SECONDS IN A REFLOW SOLDER APPLICATION WITH A 2.36mm AND 4.19mm MIN THICK CIRCUIT BOARD.

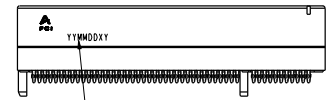

Date code:
 "YY" means year number
 "MM" means month number
 "DD" means day number
 "X" means manufacture location
 "D" means made in Dongguan site
 "Y" means shift number
 If date code is 060626D1, it means this part is made by shift 1 in 2006/06/26 and manufactured in Dongguan site
 Date code should be laser mark

PRODUCT NUMBER CODE

10055293 - X X X X X X X X

HOUSING COLOR OPTIONS
1-BLACK

PEGS OPTIONS
0-PLASTIC PEGS

TERMINAL PLATING OPTIONS

0-50u" Ni UNDERPLATE
30u" Au CONTACT AREA
100u" TIN TAIL AREA -----COMPATIBLE RoHS

3-50u" Ni UNDERPLATE
30u" Au CONTACT AREA
100u" TIN/LEAD TAIL AREA -----RoHS COMPLIANT EXCEPT Pb

LEAD FREE OPTION
"LF" FOR TERMINAL PLATING OPTION 0
LEAVE BLANK FOR TERMINAL PLATING OPTION 3

PACKAGING OPTIONS
T-TRAY PACKAGING

RESERVE
0

TAIL LENGTH OPTIONS

	DIM "D"	SUGGESTED PCB THICKNESS
0	2.00±0.20	2.36
1	3.25±0.20	4.19

tolerance unless otherwise specified	
linear	.X ± .3 .XX ± .2 .XXX ± .1
angles	0° ± 2°

FCI www.fciconnect.com		tolerance	projection	MM
Dr	MAGGIE WU	04/20/05	Product family	size A4 Scale 1.000
Eng	R Y LIU	04/20/05	Spec ref	ECN DG06-0249
Chr	PAUL WANG	04/20/05	Material	
Appr	JOSEPH HSIA	04/20/05		
cat	PCI Express ExpressModule CARD EDGE 98P PRESS-FIT ASS'Y		part no	10055293
Rev	F		CUSTOMER DRAWING	sheet 4 of 5

PDM-Rev:F STATUS:Released Printed: Nov 11, 2010

A
B
C
D

Tous droits strictement réservés. Reproduction ou utilisation non autorisée sans la permission écrite du propriétaire. Propriété de c FCI. Droits de reproduction FCI.



All rights strictly reserved. Reproduction or utilization without the permission of the proprietor. Property of FCI. Copyright FCI.

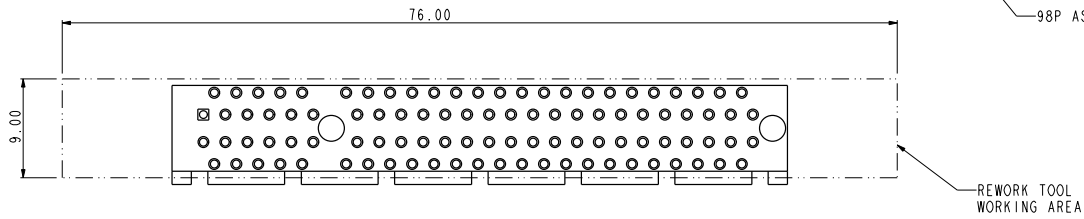

SCALE 2.000

KNOCK OUT DEFECTED CONN FROM THIS DIRECTION

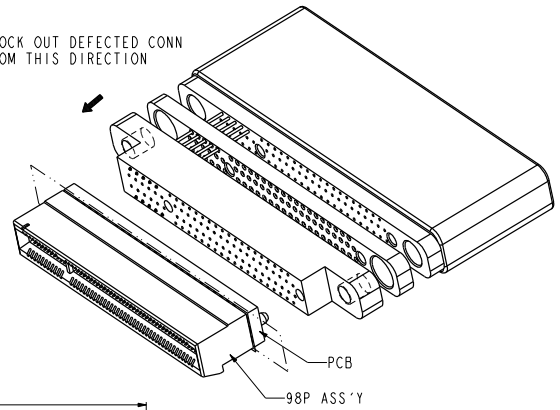

		www.fciconnect.com		tolerance	projection	MM
Dr	MAGGIE WU	04/20/05	Product family		size	Scale
Eng	R Y LIU	04/20/05	Spec ref		A4	1.000
Chr	PAUL WANG	04/20/05	Material		ECN	DG06-0249
Appr	JOSEPH HSIA	04/20/05				
title	PCI Express ExpressModule CARD EDGE 98P PRESS FIT ASS'Y			our SWB	10055293	Rev. F
catalog no	PDM: Rev:F		STATUS: Released		CUSTOMER	sheet 5 of 5 Printed: Nov-11, 2010