

REV. E 2004-01-28

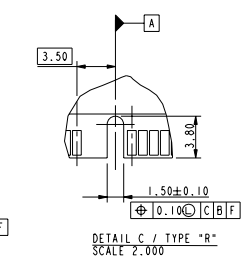
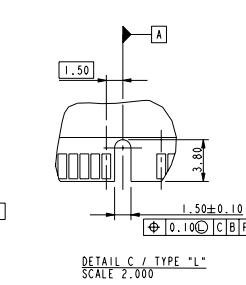
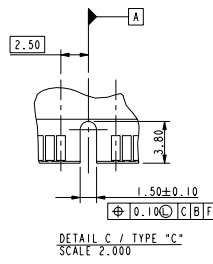
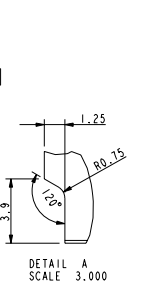
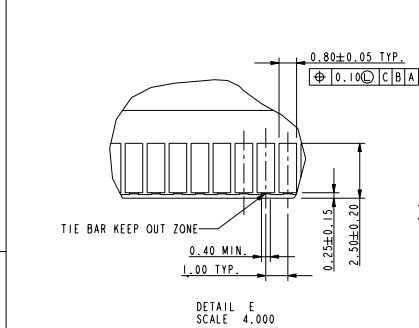
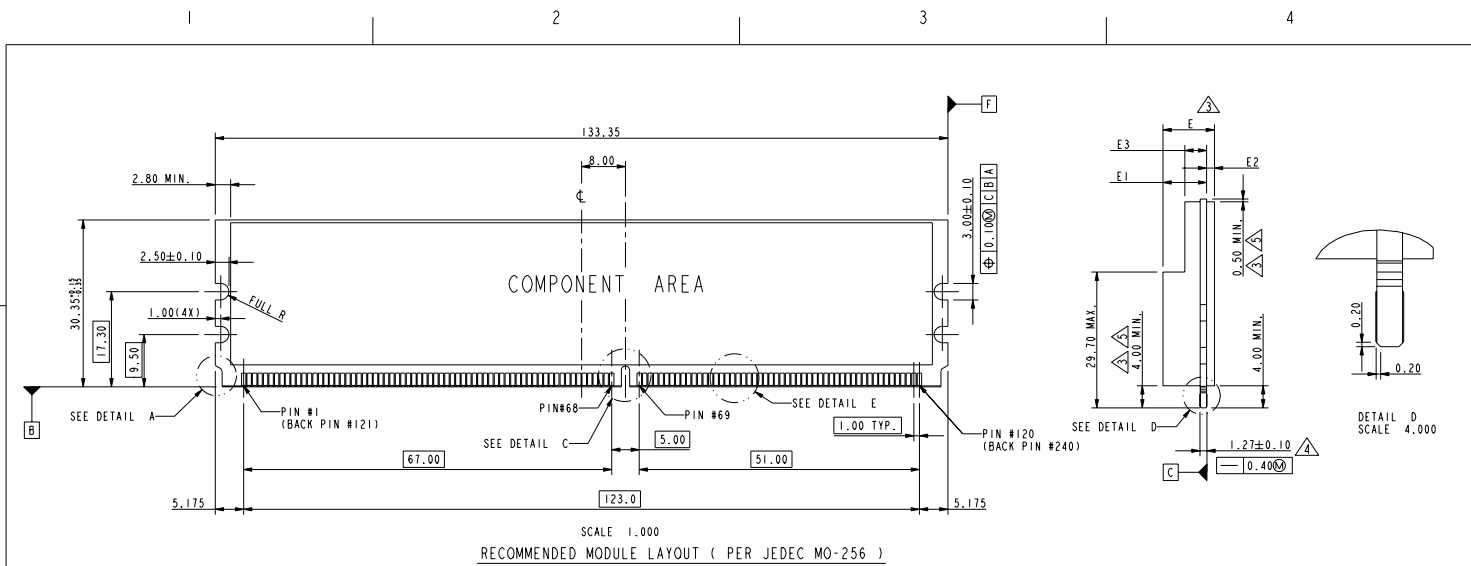

tolerances unless otherwise specified		
linear	.X	±0.38
	.XX	±0.15
	.XXX	±0.13
angles	X°	±2°

TYPE	R	X.X VOLTAGE	6.80	1.40	2.80	8.20	6.80	3.00	4.40	9.80
TYPE L	2.5 VOLTAGE	6.80	1.40	2.80	8.20	6.80	3.00	4.40	9.80	
TYPE C	1.8 VOLTAGE	6.80	1.40	2.80	8.20	6.80	3.00	4.40	9.80	
SUB KEY POS. #1	DESCRIPTION	DIM. E1 MAX.	DIM. E2 MAX.	DIM. E3 MAX.	DIM. E MAX.	DIM. E1 MAX.	DIM. E2 MAX.	DIM. E3 MAX.	DIM. E MAX.	
		TYPE 1				TYPE 2				

Mark with 10037402 REV. P in area indicated by X....		Material		Spec ref	
Dr CHARLIE S 05/30/06		Mat code		tolerance	
Eng CHARLIE S 05/30/06		Heat treat		projection	
Chr BEER FU 05/30/06		Plating/Finish		size A4 Scale 0.500	
Appr JOESPH HSIA 05/30/06		Product family		ECN DG06-0209	
		Model Name 10037402		REL Level	
		Model Revision			
		DDR11 240P, FBD1MM		Rev. P	
Prof/E file catalog		PDM: Rev:P		CUSTOMER DRAWING	
		STATUS Released		sheet 2 of 4	
				Printed: Jul 26, 2010	



This document is the property of and embodies CONFIDENTIAL and PROPRIETARY information of FCI. No part of the information shown on this document may be used, copied, disseminated, or otherwise made available to any other person without the written consent of FCI. Copyright FCI.

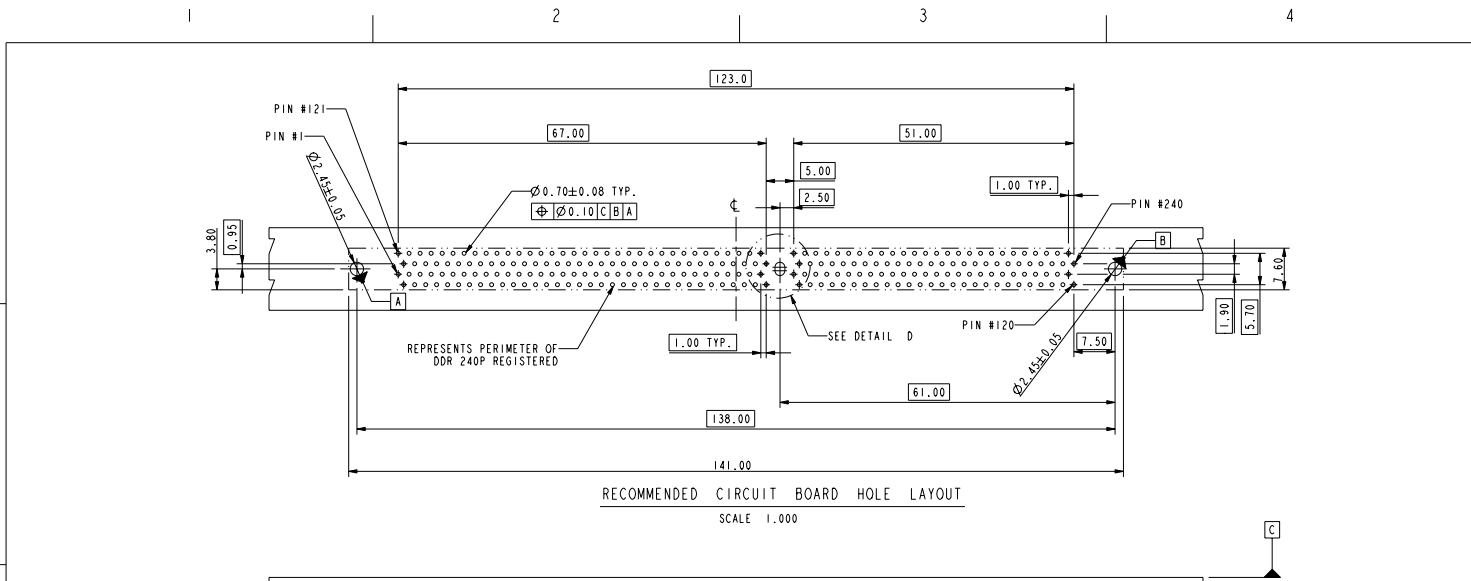

RECOMMENDED CIRCUIT BOARD HOLE LAYOUT
SCALE 1.000

DETAIL D
SCALE 4.000

OPTION 1
CENTER ROUND HOLE

OPTION 2
CENTER SLOT

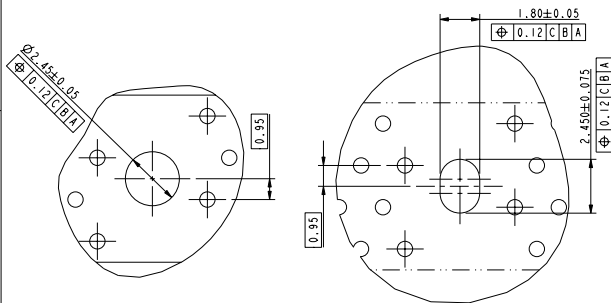

Tolerances unless otherwise specified		
linear	.X	±0.38
	.XX	±0.25
	.XXX	±0.13
angles	X°	±2°

Mark with 10037402 REV. P in area indicated by X.....	Material		Spec ref	
	Mat code		tolerance	projection
	Heat treat		✓	MM
	Plating/Finish		size	A4
Dr	CHARLIE S	05/30/06	Product family	Scale 0.500
Eng	CHARLIE S	05/30/06	Model Name	10037402
Chr	BEER FU	05/30/06	Model Revision	ECN DG06-0209
Appr	JOESPH HSIA	05/30/06	REL Level	
		Title DDR11 240P, FBD1MM		Dwg no 10037402
Prof/E file catalog		PDM: Rev:P		Rev. P

STATUS Released CUSTOMER DRAWING sheet 3 of 4
Printed: Jul 28, 2010



10037402-□ □ □ □ □

STYLE : MECHANICAL KEYING

- 1 : 1.8 VOLT. W/TYPE "C"
- 2 : 2.5 VOLT. W/TYPE "L"
- 3 : X.X VOLT. W/TYPE "R"

METAL CLIP
(WITH NI 1.27 um MIN. PLATING)

- 1 : WITH METAL CLIP + DIM. "D"=3.05
- 2 : WITH METAL CLIP + DIM. "D"=3.56
- 3 : WITH METAL CLIP + DIM. "D"=3.43

TAIL LENGTH

CODE	DIM. "B"	PCB THICKNESS
0	2.54	1.47 mm (0.058")
1	2.67	1.60 mm (0.063")
2	3.18	2.36 mm (0.093")
3	4.00	3.18 mm (0.125")

PLATING

CODE	CONTACT	SOLDERTAIL	UNDERPLATE
2	15 u"(0.38um) MIN. GOLD		
3	30u"(0.76um) MIN. GOLD	100u"(2.54um) MIN. TIN/LEAD	50u"(1.27um) MIN. NICKEL OVERALL
4	3u"(0.076um) MIN. GOLD		
7LF	15u"(0.38um) MIN. GOLD		
8LF	30u"(0.76um) MIN. GOLD	100u"(2.54um) MIN. 100% TIN	50u"(1.27um) MIN. NICKEL OVERALL
9LF	3u"(0.076um) MIN. GOLD		
2N	15 u"(0.38um) MIN. GOLD		
3N	30 u"(0.76um) MIN. GOLD	100u"(2.54um) MIN. TIN/LEAD	90u"(2.29um) MIN. NICKEL OVERALL
4N	3 u"(0.076um) MIN. GOLD		
7NLF	15 u"(0.38um) MIN. GOLD		
8NLF	30 u"(0.76um) MIN. GOLD	100u"(2.54um) MIN. 100% TIN	90u"(2.29um) MIN. NICKEL OVERALL
9NLF	3 u"(0.076um) MIN. GOLD		

COLOR OF HOUSING AND EJECTOR

- 0 : BLACK HOUSING + IVORY EJECTOR
- 1 : BLUE HOUSING + IVORY EJECTOR
- 2 : BLACK HOUSING + BLACK EJECTOR
- 3 : IVORY HOUSING + IVORY EJECTOR

NOTE:

1. MATERIAL :
HOUSING: HIGH PERFORMANCE RESINS, GLASS FILLED UL94V-0 RATED.
EJECTOR: HIGH PERFORMANCE RESINS, GLASS FILLED UL 94V-0 RATED.
TERMINAL : COPPER ALLOY.
METAL CLIP: COPPER ALLOY.
PRODUCT SPECIFICATION: GS-12-300.
2. DIMENSIONS APPLICABLE WHEN COMPONENTS MOUNTED ON ONE OR BOTH SIDES.
CARD THICKNESS APPLIES ACROSS TABS AND INCLUDES PLATING AND/OR MEALIZATION STRAIGHTNESS CALLOUT APPLIES TO ZONE DEFINED BY THE 4.00 CONTACT AREA DIMENSION FOR THE ENTIRE LENGTH OF 133.35.
3. BOARD OF COMPONENT AREA.
4. LATCH DESIGN INCLUDES COMPLEMENTARY FEATURE TO ACCOMMODATE MODULE END NOTCHES AS DEFINED IN DETAIL A OF P.2 AND AS SPECIFIED IN MO-256.
5. THIS PRODUCT MEETS EUROPEAN UNION DIRECTIVES AND OTHER COUNTRY REGULATIONS AS DESCRIBED IN GS-22-008.
6. THE HOUSING WILL WITHSTAND EXPOSURE TO 260°C PEAK TEMP. FOR 10 SECONDS IN A WAVE SOLDER APPLICATION.
7. 10037402-XXXXXX1LF SERIES ARE FOR LEAD-FREE OPTIONS.
8. DATE CODE: XXXXX** SHOWS DAY/MONTH/YEAR. ** MEANS PRODUCTION LINE CODE.
EX:122505 MEANS 12/25/2005.WILL BE PRINTED ON SOCKET.

TOLERANCES UNLESS OTHERWISE SPECIFIED		
LINEAR	0.X	±0.3
	0.XX	±0.15
	0.XXX	±0.100
ANGULAR	0°	±2°

Mark with 10037402 REV. P in area indicated by X..... <table border="1"> <thead> <tr> <th>rev</th> <th>ech no</th> <th>dr</th> <th>date</th> </tr> </thead> <tbody> <tr><td>-</td><td>-</td><td>-</td><td>-</td></tr> <tr><td>-</td><td>-</td><td>-</td><td>-</td></tr> <tr><td>-</td><td>-</td><td>-</td><td>-</td></tr> <tr><td>-</td><td>-</td><td>-</td><td>-</td></tr> <tr><td>-</td><td>-</td><td>-</td><td>-</td></tr> <tr><td>-</td><td>-</td><td>-</td><td>-</td></tr> <tr><td>-</td><td>-</td><td>-</td><td>-</td></tr> <tr><td>-</td><td>-</td><td>-</td><td>-</td></tr> <tr><td>-</td><td>-</td><td>-</td><td>-</td></tr> </tbody> </table>	rev	ech no	dr	date	-	-	-	-	-	-	-	-	-	-	-	-	-	-	-	-	-	-	-	-	-	-	-	-	-	-	-	-	-	-	-	-	-	-	-	-	Material		Spec ref		tolerance	projection	size	Scale
	rev	ech no	dr	date																																												
	-	-	-	-																																												
	-	-	-	-																																												
	-	-	-	-																																												
	-	-	-	-																																												
	-	-	-	-																																												
	-	-	-	-																																												
	-	-	-	-																																												
	-	-	-	-																																												
-	-	-	-																																													
Mat code		✓		A4	MM																																											
Heat treat		Product family				ECN		DG06-0209																																								
Plating/Finish		Model Name		Model Revision		REL Level																																										
Dr	CHARLIE S	05/30/06																																														
Eng	CHARLIE S	05/30/06																																														
Chr	BEER FU	05/30/06																																														
Appr	JOESPH HSIA	05/30/06																																														
FCI		title		849g no		Rev.																																										
DDR11 240P. FBD1MM		10037402		P																																												
Prof/E file		catalog		PDM: Rev:P		STATUS Released																																										