

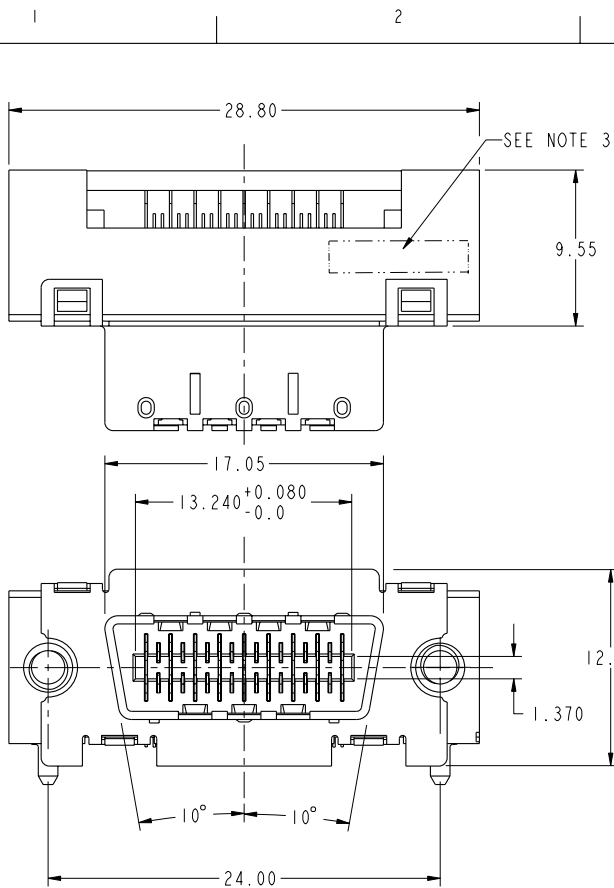

Copyright FCI.

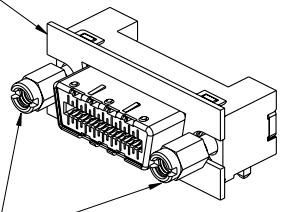

AVAILABLE WITH OR WITHOUT EMI GASKET.
 FOAM GASKET P/N 10019396-001 CAN BE PURCHASED SEPARATELY.
 METAL GASKET P/N 10043517 MUST BE PURCHASED ALREADY ASSEMBLED.



P/N 10009634-001, 2X THREADED STANDOFFS SOLD SEPARATELY

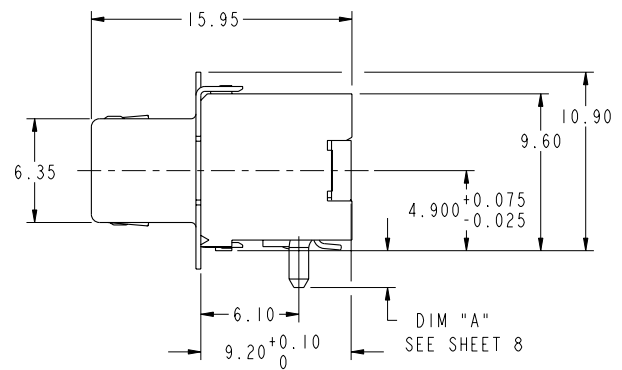

rev	ecn no	dr	date
D	V04-0460	DAI	2004/06/08
E	V04-0830	TAB	2004/08/18
F	V04-1005	DAI	2004/10/06
G	V05-0063	TAB	2005/02/14
H	105-0141	HVN	2005/08/12
J	06-0123	HVN	2006/07/26
K	08-0048	RPK	2008/03/28

www.fciconnect.com		surface 3.2 / ASME Y14.5	tolerance std ASME Y14.5	projection	MM
Dr G. PETERS 2003/08/13		ANGULAR	LINEAR	size A4	Scale 3:1
Eng D. BRANN 2003/08/13		0° ±2°	0.X ±.30 0.XX ±.10 0.XXX ±.050	ECN 108-0048	
Chr RAMESH P K 2008/03/27		Product family EyeMax (Im)		Spec ref	-
Appr RAMESH P K 2008/03/27		FCI		4X R/A THUMBSCREW RECPT ASSEMBLY, w/ 7 KEY SLOTS	Rev. K
catalog no		-		10009629	sheet 1 of 9



Copyright FCI.

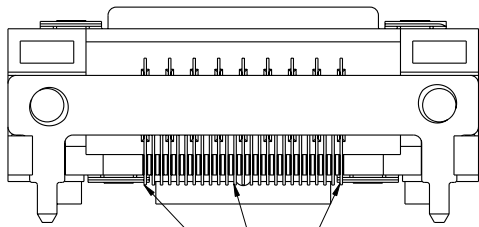

0.13 D

COPLANARITY MEASUREMENT TO BE TAKEN AT THE BOTTOM MOST POINT ON CONTACT TAILS
COPLANARITY ZONE IS BELOW DATUM D.

CROSS HATCH AREA IS FOR VACUUM PICK & PLACE REF. ONLY

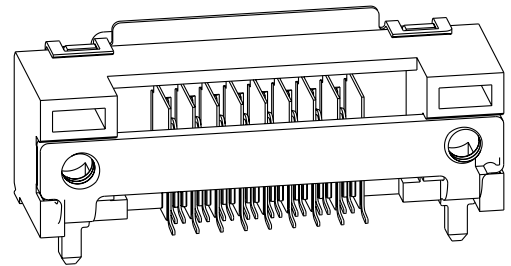
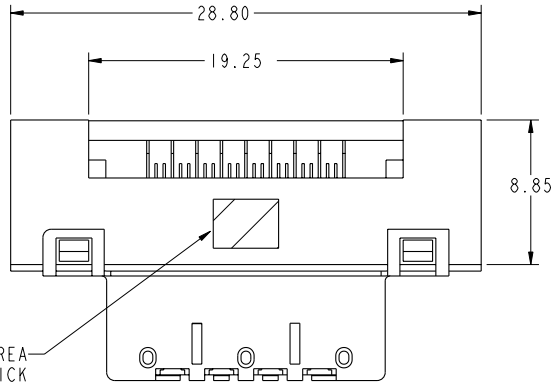

www.fciconnect.com		surface 3.2 ASME Y14.5	tolerance std ASME Y14.5	projection MM
TOLERANCES UNLESS OTHERWISE SPECIFIED		ANGULAR	LINEAR	size A4
Dr	G. PETERS	2003/08/13	0.X ±.30	Scale 3:1
Eng	D. BRANN	2003/08/13	0.XX ±.10	ECN 108-0048
Chr	RAMESH P K	2008/03/27	0°. ±2°	Product family EyeMax (tm)
Appr	RAMESH P K	2008/03/27	0.xxx ±.050	Spec ref -
FCI		title 4X R/A THUMBSCREW RECPT ASSEMBLY, w/ 7 KEY SLOTS		Rev. K
catalog no		-		10009629
-		CUSTOMER		sheet 2 of 9

REV 1 - 2006-04-17

PDM: Rev:K

STATUS Released

Printed: Apr 02, 2008



Copyright FCI.

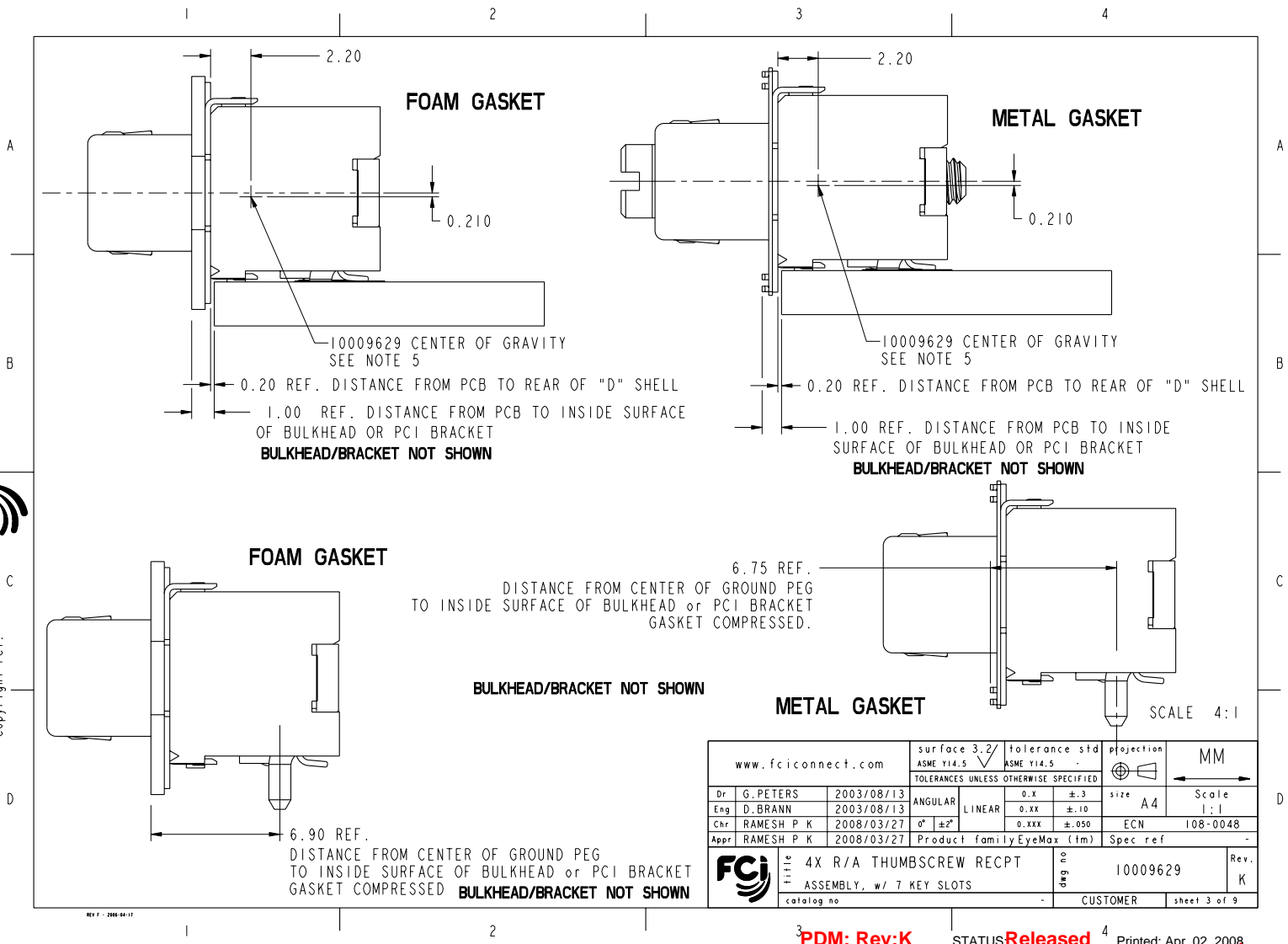

www.fciconnect.com		surface 3.2 ASME Y14.5	tolerance std ASME Y14.5	projection MM
		TOLERANCES UNLESS OTHERWISE SPECIFIED		size A4
Dr	G. PETERS	2003/08/13	ANGULAR	Scale 1:1
Eng	D. BRANN	2003/08/13	LINEAR	ECN 108-0048
Chr	RAMESH P K	2008/03/27	0° ±2°	Product family EyeMax (Im)
Appr	RAMESH P K	2008/03/27	0.xxx ±.050	Spec ref -
FCI		Title 4X R/A THUMBSCREW RECPT ASSEMBLY, w/ 7 KEY SLOTS		Rev. K
catalog no		-		10009629
		CUSTOMER		sheet 3 of 9



Copyright FCI.

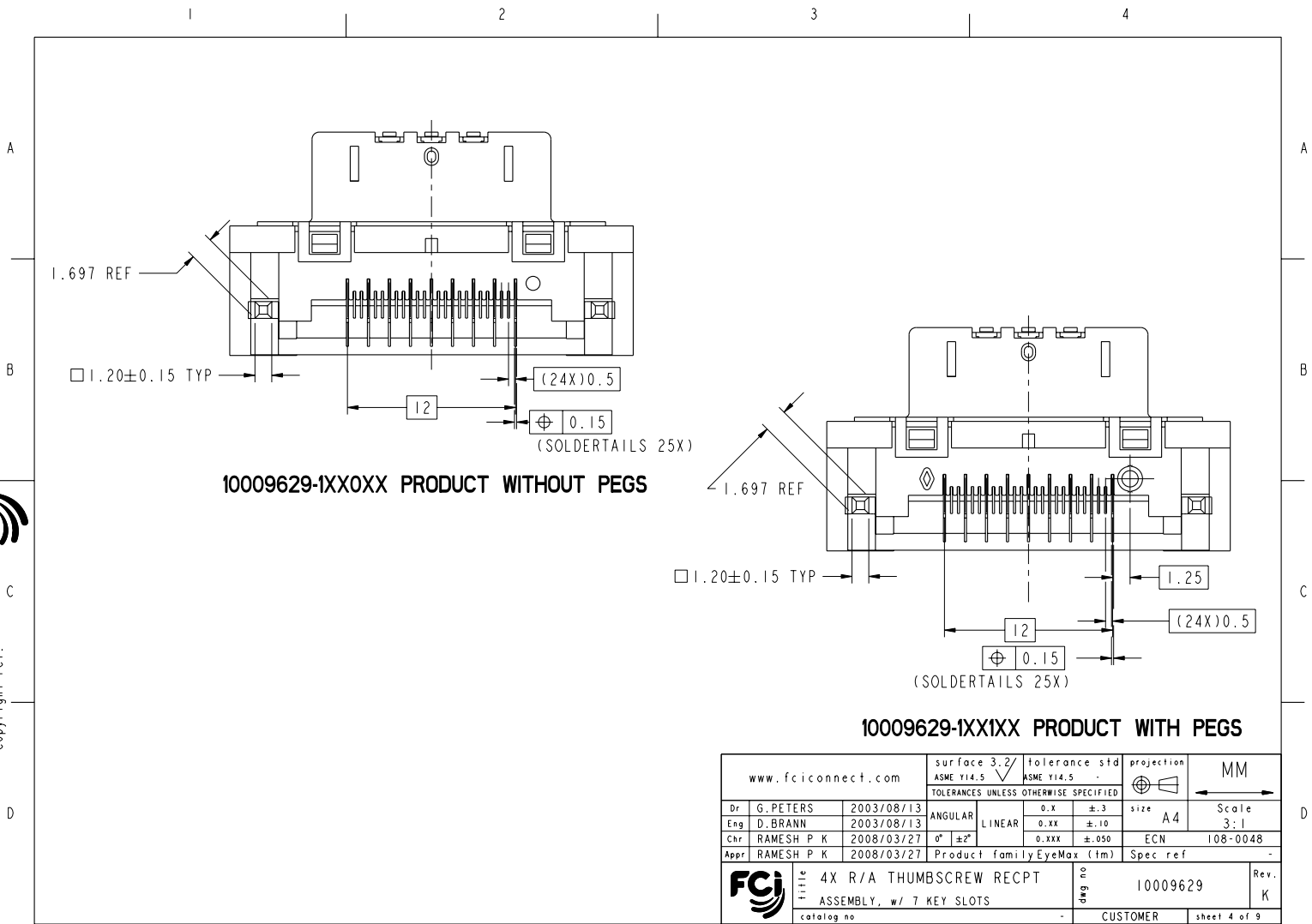

REV F - 2006-03-17

www.fciconnect.com		surface 3.2 ASME Y14.5	tolerance std ASME Y14.5	projection MM									
TOLERANCES UNLESS OTHERWISE SPECIFIED		<table border="1"> <tr> <td>ANGULAR</td> <td>0.X</td> <td>±.3</td> </tr> <tr> <td>LINEAR</td> <td>0.XX</td> <td>±.10</td> </tr> <tr> <td>0° ±2°</td> <td>0.XXX</td> <td>±.050</td> </tr> </table>			ANGULAR	0.X	±.3	LINEAR	0.XX	±.10	0° ±2°	0.XXX	±.050
ANGULAR	0.X	±.3											
LINEAR	0.XX	±.10											
0° ±2°	0.XXX	±.050											
Dr G. PETERS	2003/08/13	size A4	Scale 3:1										
Eng D. BRANN	2003/08/13	ECN 108-0048											
Chr RAMESH P K	2008/03/27	Product family EyeMax (Im)	Spec ref										
Appr RAMESH P K	2008/03/27												
	title 4X R/A THUMBSCREW RECPT ASSEMBLY, w/ 7 KEY SLOTS	cat no	10009629	Rev. K									
			CUSTOMER	sheet 4 of 9									

3 PDM: Rev:K STATUS Released 4 Printed: Apr 02, 2008



Copyright FCI.

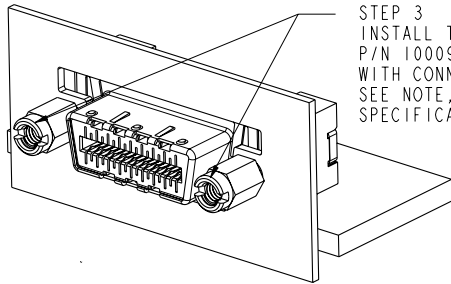

STEP 3
INSTALL THREADED STANDOFFS
P/N 10009634-001, NOT SUPPLIED
WITH CONNECTOR ASSEMBLY
SEE NOTE, SHEET 8, FOR TORQUE
SPECIFICATION.

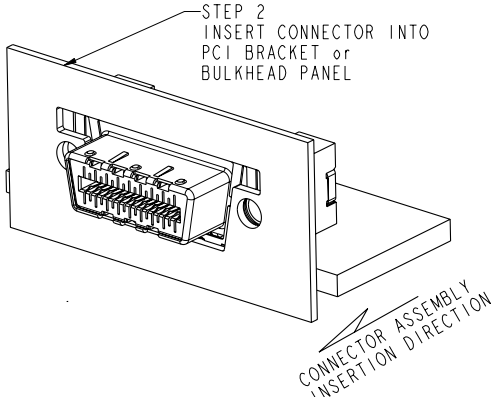

STEP 2
INSERT CONNECTOR INTO
PCI BRACKET or
BULKHEAD PANEL

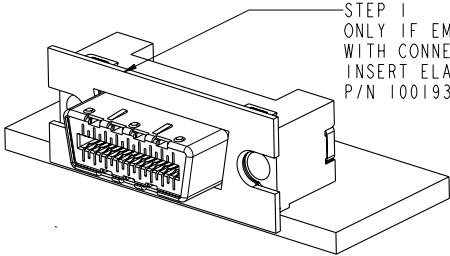

STEP 1
ONLY IF EMI GASKET NOT SUPPLIED
WITH CONNECTOR ASSEMBLY,
INSERT ELASTOMERIC EMI GASKET,
P/N 10019396-001.

CONNECTOR APPLICATION TO PCI BRACKET/PANEL

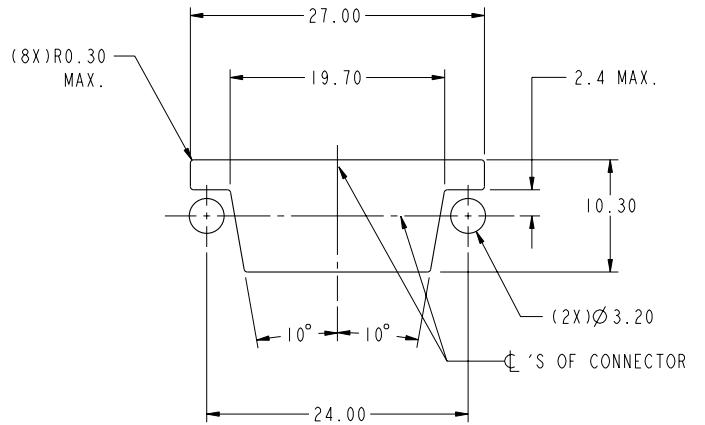

RECOMMENDED PANEL CUTOUT

www.fciconnect.com			surface 3.2/ ASME Y14.5	tolerance std ASME Y14.5	projection MM
			TOLERANCES UNLESS OTHERWISE SPECIFIED		
Dr	G. PETERS	2003/08/13	ANGULAR	0.X ±.30	size A4 Scale 1:1
Eng	D. BRANN	2003/08/13	LINEAR	0.XX ±.10	ECN 108-0048
Chr	RAMESH P K	2008/03/27	0° ±2°	0.XXX ±.050	Spec ref -
Appr	RAMESH P K	2008/03/27	Product family EyeMax (Im)		
FCI			4X R/A THUMBSCREW RECPT ASSEMBLY, w/ 7 KEY SLOTS		Rev. K
catalog no			10009629		sheet 5 of 9

3 PDM: Rev:K

STATUS Released

4 Printed: Apr 02, 2008

REV F - 2006-03-17



Copyright FCI.

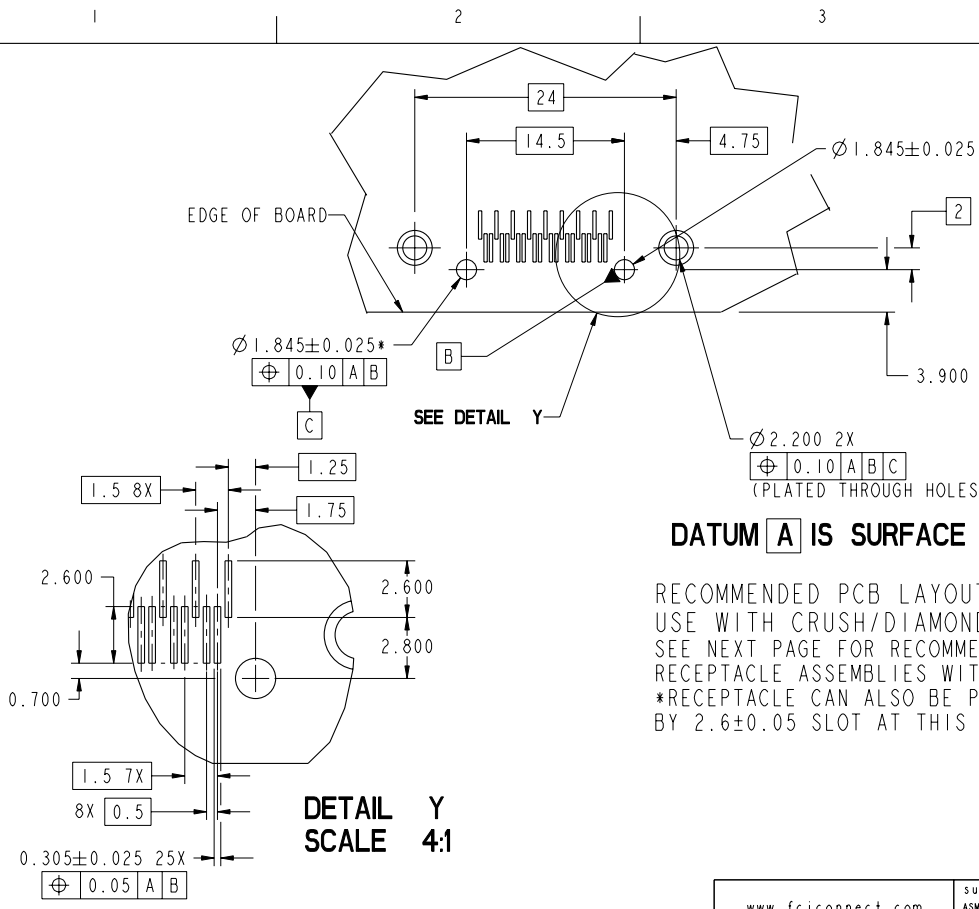

DATUM A IS SURFACE OF PCB

RECOMMENDED PCB LAYOUT, COMPONENT SIDE FOR USE WITH CRUSH/DIAMOND PEGS (10009629-1XX1XX) SEE NEXT PAGE FOR RECOMMENDED PCB LAYOUT FOR RECEPTACLE ASSEMBLIES WITHOUT CRUSH/DIAMOND PEGS. *RECEPTACLE CAN ALSO BE PLACED WITH 1.82±0.05/-0.0 BY 2.6±0.05 SLOT AT THIS LOCATION ON THE PCB

REV F - 2006-04-17

www.fciconnect.com		surface 3.2/ ASME Y14.5	tolerance std ASME Y14.5	projection MM
Dr G. PETERS 2003/08/13		TOLERANCES UNLESS OTHERWISE SPECIFIED		size A4
Eng D. BRANN 2003/08/13		ANGULAR	0.X ±.30	Scale 1:1
Chr RAMESH P K 2008/03/27		LINEAR	0.XX ±.10	ECN 108-0048
Appr RAMESH P K 2008/03/27		0° ±2°	0.XXX ±.050	Spec ref -
Product family EyeMax (Im)		Title 4X R/A THUMBSCREW RECPT ASSEMBLY, w/ 7 KEY SLOTS		Rev. K
catalog no		Part no 10009629		sheet 6 of 9
		CUSTOMER		

PDM: Rev:K

STATUS Released

Printed: Apr 02, 2008



Copyright FCI.

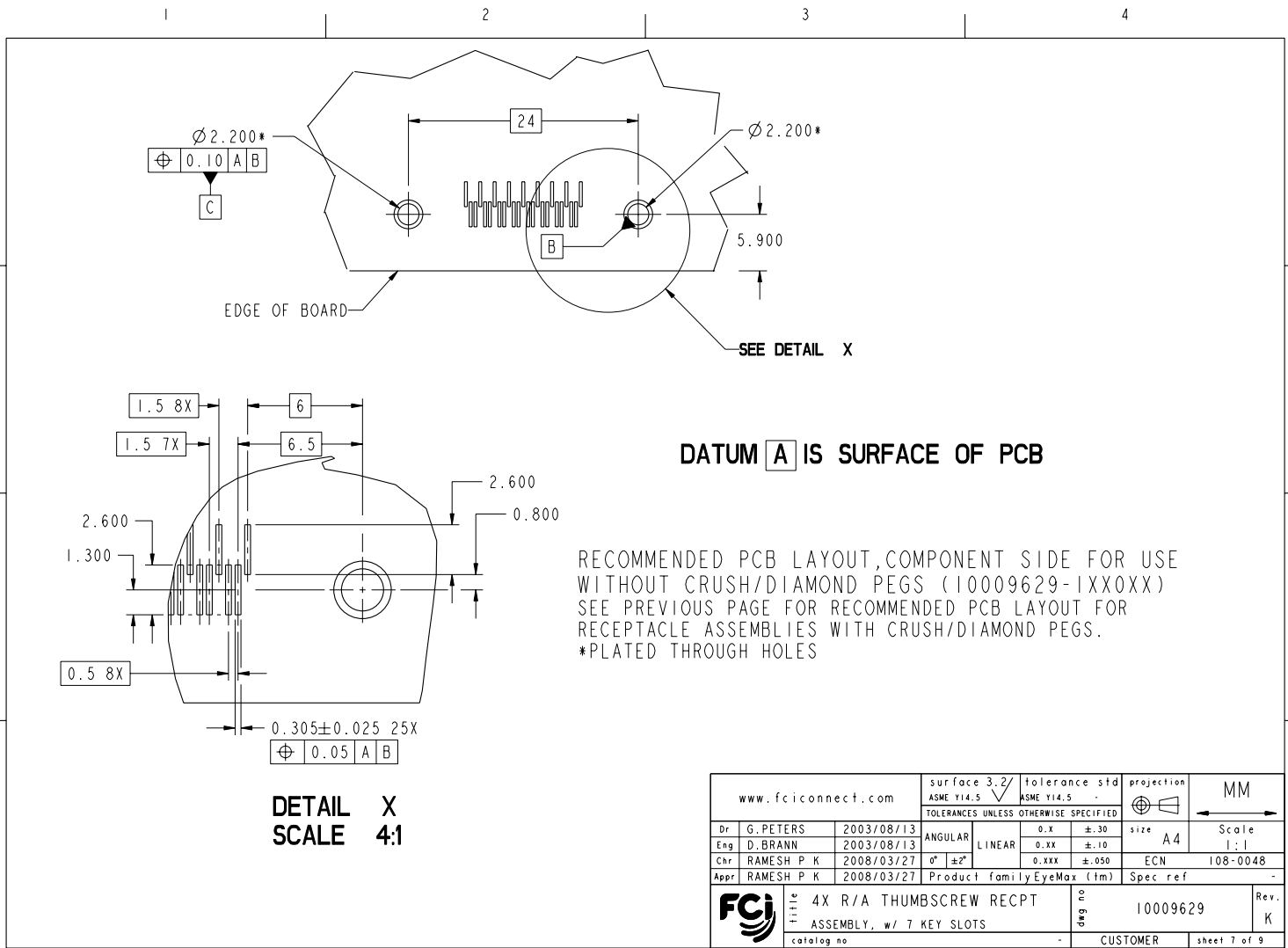

DATUM A IS SURFACE OF PCB

RECOMMENDED PCB LAYOUT, COMPONENT SIDE FOR USE WITHOUT CRUSH/DIAMOND PEGS (10009629-1XX0XX)
SEE PREVIOUS PAGE FOR RECOMMENDED PCB LAYOUT FOR RECEPTACLE ASSEMBLIES WITH CRUSH/DIAMOND PEGS.
*PLATED THROUGH HOLES

DETAIL X
SCALE 4:1

www.fciconnect.com		surface 3.2 ASME Y14.5	tolerance std ASME Y14.5	projection MM
TOLERANCES UNLESS OTHERWISE SPECIFIED		ANGULAR	LINEAR	size A4
Dr G. PETERS	2003/08/13	0° ±2°	0.X ±.30	Scale 1:1
Eng D. BRANN	2003/08/13	0.XX ±.10	0.XXX ±.050	ECN 108-0048
Chr RAMESH P K	2008/03/27	Product family EyeMax (Im)	Spec ref	-
Appr RAMESH P K	2008/03/27	FCI		Rev. K
Title 4X R/A THUMBSCREW RECEPT ASSEMBLY, w/ 7 KEY SLOTS		cat no	10009629	sheet 7 of 9

REV 1 - 2006-04-17



Copyright FCI.

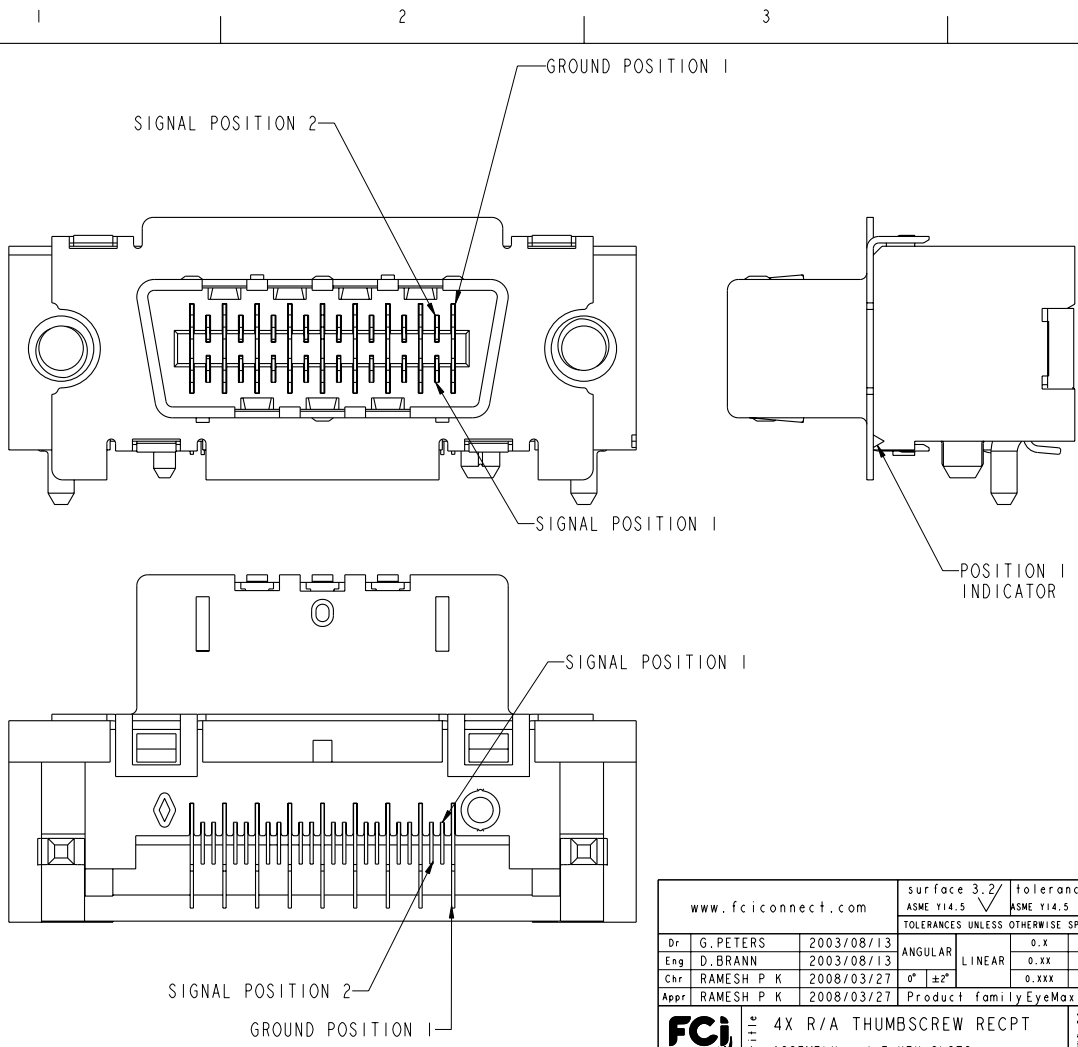

REV 1 - 2006-03-17

www.fciconnect.com		surface 3.2 ASME Y14.5	tolerance std ASME Y14.5	projection MM
TOLERANCES UNLESS OTHERWISE SPECIFIED		ANGULAR	LINEAR	size A4
Dr	G. PETERS	2003/08/13	0.X ±.30	Scale 1:1
Eng	D. BRANN	2003/08/13	0.XX ±.10	ECN 108-0048
Chr	RAMESH P K	2008/03/27	0°. ±2°	0.XXX ±.050
Appr	RAMESH P K	2008/03/27	Product family EyeMax (Im)	Spec ref -
FCI		4X R/A THUMBSCREW RECPT ASSEMBLY, w/ 7 KEY SLOTS		Rev. K
catalog no		-		10009629
-		CUSTOMER		sheet 8 of 9

3 PDM: Rev:K STATUS Released 4 Printed: Apr 02, 2008



Copyright FCI.

PRODUCT NUMBER
10009629-1XXXXX

10009629-1XXXXXX

- SOLDERTAIL PLATING
BLANK-TIN-LEAD
LF-LEAD FREE (SEE NOTE 2)
- KEYING OPTIONS
0-NONE
- PACKAGING
1-TAPE & REEL
2-TRAY
3-TAPE & REEL WITH THREADED STAND-OFFS INCLUDED
(PACKAGED SEPERATELY). 2 PER CONNECTOR.
4-TRAY WITH THREADED STAND-OFFS INCLUDED
(PACKAGED SEPERATELY). 2 PER CONNECTOR.
- PEGS
0-NONE
1-CRUSH/DIAMOND PEGS
- PCB THICKNESS
1-1.6mm
2-2.4mm
3-4.0mm
- EMI GASKET
0-WITH FOAM GASKET
1-WITHOUT GASKET
2-WITH METAL GASKET (NOT TOOLED)
- PLATING
GOLD OVER NICKEL IN CONTACT AREA

CONNECTOR NOTES:

- ① HOUSING MATERIAL: UL94 V-0 LCP RESIN.
SIGNAL PIN MATERIAL: COPPER ALLOY.
GROUND CONTACT MATERIAL: COPPER ALLOY.
- ② PLATING: LEAD FREE SOLDER TAILS 2μm (80μin) MIN MATTE TIN
OVER 1.27μm (50μin) MIN NICKEL UNDERPLATE.
- ③ P/N AND DATE CODE TO APPEAR
ON THIS SURFACE.
4. PRODUCT SPECIFICATION GS-12-209.
APPLICATION SPECIFICATION GS-20-025.
5. CONNECTOR WEIGHT = 5.465 grams
6. PACKAGING SPECIFICATION GS-14-794. PACKAGING OF LEAD FREE
PRODUCTS MEETS LABELING AND PACKAGING SPECIFICATION GS-14-920.
7. MAXIMUM PANEL THICKNESS 1.70mm
- ⑧ MAXIMUM TORQUE 0.45 N-m (4.0 lbf-in)

PCB NOTES:

9. ALL DIMENSIONS ARE BASIC UNLESS OTHERWISE
SPECIFIED.
10. ALL HOLE DIAMETERS ARE FINISHED HOLE SIZE
11. MATES WITH EYEMAX® PLUG 58443 (WITHOUT PCB), 58638
(WITH UNEQUALIZED PCB) OR 10026692 (WITH EQUALIZED PCB).
12. LEAD FREE PRODUCTS MEET EUROPEAN UNION DIRECTIVES AND
OTHER COUNTRY REGULATIONS AS DESCRIBED IN GS-22-008.
13. THE HOUSING WILL WITHSTAND EXPOSURE TO 260°C PEAK TEMPERATURE
FOR 15 SECONDS IN A CONVECTION, INFRARED OR VAPOR PHASE REFLOW
OVEN.

PRODUCT NUMBER	BOARD THICKNESS	DIM A
10009629-1X1XXX	1.6mm	2.3mm
10009629-1X2XXX	2.4mm	3.1mm
10009629-1X3XXX	4.0mm	4.7mm

www.fciconnect.com		surface 3.2 ASME Y14.5	tolerance std ASME Y14.5	projection	MM
		TOLERANCES UNLESS OTHERWISE SPECIFIED			
Dr	G. PETERS	2003/08/13	ANGULAR	0.X ±.30	size A4 Scale 1:1
Eng	D. BRANN	2003/08/13	LINEAR	0.XX ±.10	ECN 108-0048
Chr	RAMESH P K	2008/03/27	0° ±2°	0.XXX ±.050	Spec ref -
Appr	RAMESH P K	2008/03/27	Product family EyeMax (Im)		
		title 4X R/A THUMBSCREW RECPT		dag no 10009629	Rev. K
		catalog no		CUSTOMER	sheet 9 of 9

REV F - 2006-04-17