

THIS DRAWING IS UNPUBLISHED
 UNLESS INDICATED OTHERWISE
 © 1978 BY TYS ELECTRONICS CORPORATION ALL INFORMATION HEREIN IS UNCLASSIFIED

REV	DATE	DESCRIPTION	BY	CHK	APP
DF	DO	SEE SHEET 1	-	-	-

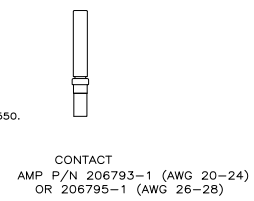
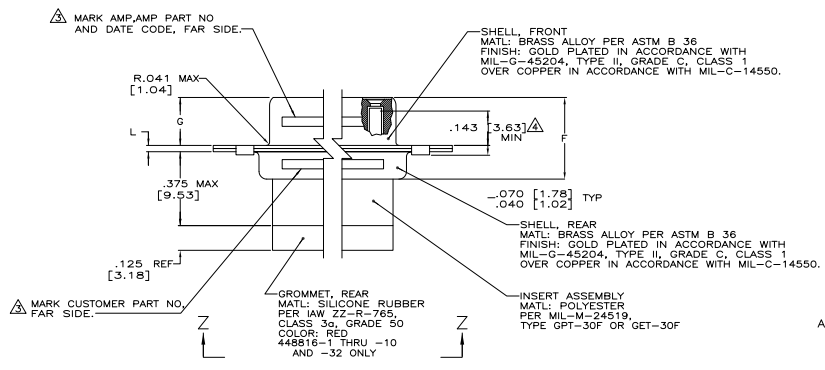
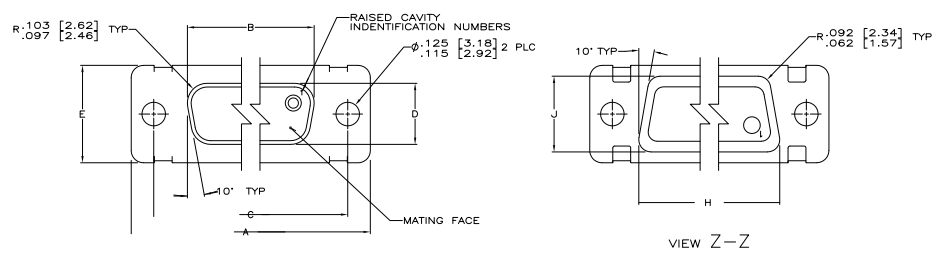

THIS DRAWING IS A CONTROLLED DOCUMENT.		DATE: 2-11-83	BY: J. GENY	REV: 2
DRAWN BY: J. GENY		DATE: 2-11-83	BY: J. GENY	REV: 2
CHECKED BY: J. GENY		DATE: 2-11-83	BY: J. GENY	REV: 2
APPROVED BY: J. GENY		DATE: 2-11-83	BY: J. GENY	REV: 2
TYS ELECTRONICS CORPORATION		Harrisburg, PA 17105-3608		
PROJECT: AMP		MIL-C-24308		
DESCRIPTION: AMPLIMITE NONMAGNETIC RECEPTACLE ASSY WITH SIZE 20 CRIMP TYPE SOCKET CONTACTS, SERIES 109,		REV: 2		
SIZE: A1	DATE: 00779	ISSUE: G=448816	REV: 2	REV: 2
CUSTOMER DRAWING		PAGE: 2 OF 2		