

## 0433/8433

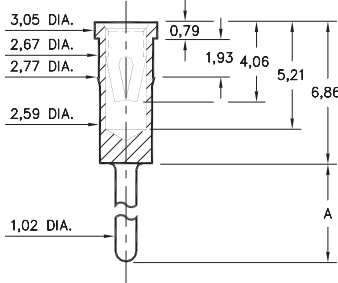

Basic Part Number	Length A
0433-0	3,05
8433-0	8,38

**X433-0-15-XX-03-XX-04-0**  
Press-fit in 2,69 mounting hole

## 0435/0436

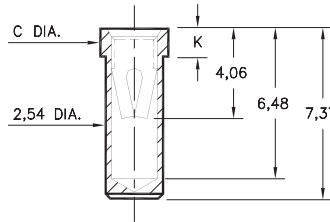

Basic Part Number	Dia. C	Length K
0435-0	3,0	1,27
0436-0	3,18	1,78

**0435-0-15-XX-03-XX-10-0**  
Solder mount in 2,59 min. mounting hole  
Also available on 24mm wide carrier tape: 950 parts per 330mm reel.  
Order as: 0435-0-57-XX-03-XX-10-0

## 4064

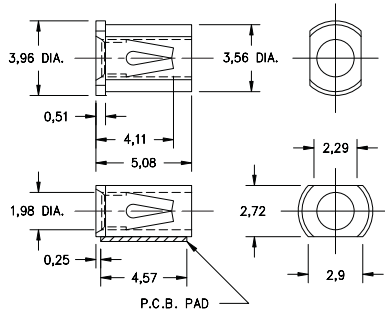

**4064-0-18-XX-03-XX-40-0**  
Surface mount  
Also available on 16mm wide carrier tape: 2,400 parts per 330mm reel.  
Order as: 4064-0-58-XX-03-XX-40-0



P.C.B. Layout

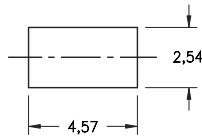

## 0342

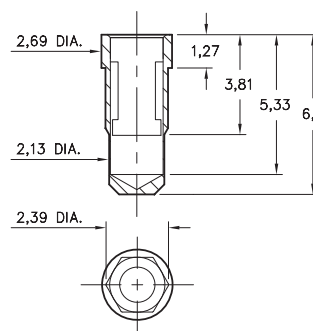

• 0342 receptacle uses Mill-Max's new #42 Contact. This receptacle will accept the  $\varnothing 1,55 \pm 0,05$  power pins of 1/4 brick DC/DC converters.

• #42 contact can be ordered in standard receptacles that use #03 contact; or it can be specified as the spring element inside custom made receptacles.

**0342-0-15-XX-42-XX-10-0**  
Hex press-fit in  $2,29 \pm 0,05$  plated thru hole

## 0434

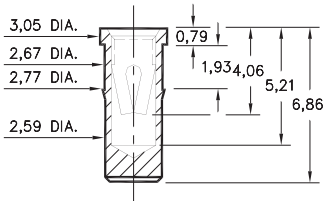

**0434-0-15-XX-03-XX-10-0**  
Press-fit in 2,69 mounting hole

### Mechanical Data #42 Contact:

Insertion/Extraction Force with a  $\varnothing 1,55$  (nominal) pin:

First Cycle		2nd & Subsequent Cycles	
Insertion Force	Extraction Force	Insertion Force	Extraction Force
20N	6N	10N	6N

Compliance Test (the "spring back" characteristic of the contact to accept  $\varnothing 1,5$  small pin after insertion of a  $\varnothing 1,6$  large pin) :

Initial Cycle with $\varnothing 1,5$ pin		Second Cycle with $\varnothing 1,6$ pin		Third Cycle with $\varnothing 1,5$ pin	
Ins. Force	Ext. Force	Ins. Force	Ext. Force	Ins. Force	Ext. Force
18N	6N	22N	7N	3N	2N

(Insertion/Extraction Forces are in Newtons and measured with polished steel gage pins having elliptical shaped tips).

## SPECIFICATIONS

**SHELL MATERIAL:**  
Brass Alloy 360, 1/2 Hard

**CONTACT MATERIAL:**  
Beryllium Copper Alloy 172, HT

**DIMENSION IN INCHES TOLERANCES ON:**  
LENGTHS:  $\pm 0,13$   
DIAMETERS:  $\pm 0,05$   
ANGLES:  $\pm 2^\circ$

ORDER CODE: **XXXX - X - 1X - XX - XX - XX - XX - 0**

BASIC PART #

SPECIFY SHELL FINISH:

- 01 5,08 m TIN/LEAD OVER NICKEL
- ◇ 80 5,08 m TIN OVER NICKEL (RoHS)
- ◇ 15 0,25 m GOLD OVER NICKEL (RoHS)

SPECIFY CONTACT FINISH:

- 01 5,08 m TIN/LEAD OVER NICKEL
- ◇ 80 5,08 m TIN OVER NICKEL (RoHS)
- ◇ 27 0,76 m GOLD OVER NICKEL (RoHS)



SELECT CONTACT

#03 or #42 CONTACT (DATA ON PAGE 224)