

RoHS HF 157 Series – Standard Nano Fuse and Clip Assembly



Description

The 157 Series – Standard Nano Fuse/Clip assembly is a small, square, very fast acting surface mount fuse that is assembled in surface mountable fuse clips. The fuse clip and pre-installed fuse combination can be automatically placed in PC Board in one efficient manufacturing operation. It permits quick and easy replacement of fuses without performing desoldering process, even in the field and without exposing the PC Board to detrimental effects of rework solder heat.

Features

- Surface Mountable, Very Fast Acting Fuse.
- Fully compatible with RoHS/Pb-Free solder alloys and higher temperature profiles associated with leadfree assembly.
- Easily replaceable on PC Board (Field Replaceable)
- RoHS compliant and Halogen Free
- Available in ratings of 0.062 ~ 10 Amperes.

Agency Approvals

AGENCY	AGENCY FILE NUMBER	AMPERE RANGE
	E14721	0.062A ~ 10A
	NBK030205-E10480A NBK030205-E10480B NBK101105-E184655	1A 1.5A - 5A 6.3A - 10A

Electrical Characteristics for Series

% of Ampere Rating	Opening Time at 25°C
100%	4 hours Minimum
200%	5 secs. Maximum

Applications

- Instrumentation
- Base Stations
- Telecommunications

Electrical Specifications by Item

Ampere Rating (A)	Amp Code	Max Voltage Rating (V)	Interrupting Rating (A)	Fuse Furnished	Nominal Cold Resistance (Ohms)	Nominal Melting I ² t (A ² sec)	Agency Approvals	
0.062	.062	125	50A @ 125 VAC/VDC 300A @ 32 VDC	0451.062	5.5372	0.00019	X	
0.080	.080	125		0451.080	4.0500	0.00033	X	
0.100	.100	125		0451.100	3.1000	0.00138	X	
0.125	.125	125		0451.125	1.7059	0.00286	X	
0.160	.160	125		0453.160	1.2157	0.0048	X	
0.200	.200	125		0453.200	1.3971	0.00652	X	
0.250	.250	125		0453.250	1.0496	0.01126	X	
0.315	.315	125		0453.315	0.3881	0.0311	X	
0.375	.375	125		0453.375	0.6083	0.0425	X	
0.400	.400	125		0453.400	0.5600	0.0484	X	
0.500	.500	125		0453.500	0.4181	0.0795	X	
0.630	.630	125		0453.630	0.3050	0.143	X	
0.750	.750	125		0453.750	0.2458	0.185	X	
0.800	.800	125		0453.800	0.2120	0.271	X	
1.0	001.	125		0453001.	0.1537	0.459	X	X
1.25	1.25	125		04531.25	0.078	0.664	X	X
1.5	01.5	125		045301.5	0.0634	0.853	X	X
1.6	01.6	125		045301.6	0.0580	1.060	X	X
2.0	002.	125		0453002.	0.0373	0.530	X	X
2.5	02.5	125		045302.5	0.0288	1.029	X	X
3.0	003.	125	0453003.	0.0229	1.650	X	X	
3.15	3.15	125	04533.15	0.0215	1.920	X	X	
3.5	03.5	125	045303.5	0.0203	2.469	X	X	
4.0	004.	125	0453004.	0.0163	3.152	X	X	
5.0	005.	125	0453005.	0.0127	5.566	X	X	
6.3	06.3	125	045306.3	0.0098	9.17	X	X	
7.0	007.	125	0453007.	0.0092	10.32	X	X	
8.0	008.	125	0453008.	0.0079	20.23	X	X	
10.0	010.	125	35A @ 125 VAC / 50A @125 VDC 300A @ 32VDC	0453010.	0.0058	26.46	X	X

1. Cold resistance measured at less than 10% of rated current at 23°C.
 2. I²t values stated for 8ms opening time.
 3. Agency Approval Table Key: X=Approved or Certified, P=Pending and Blank=Not Approved
 4. Have special electrical characteristic needs? Contact Littelfuse to learn more about application specific options.

Temperature Derating Curve

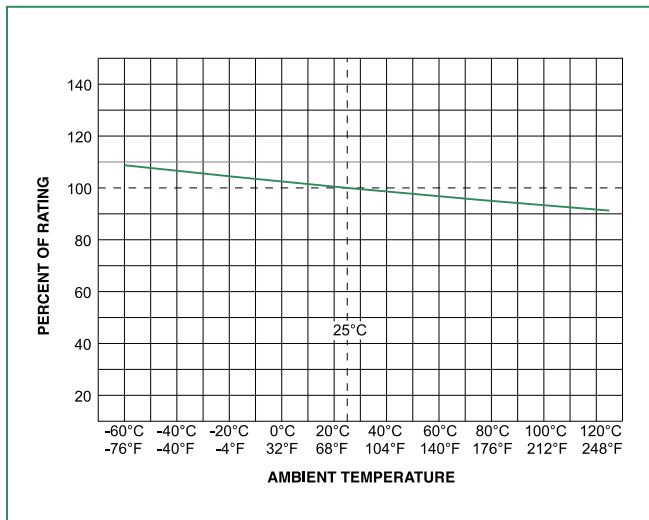

Note:

1. Derating depicted in this curve is in addition to the standard derating of 25% for continuous operation.

Average Time Current Curves

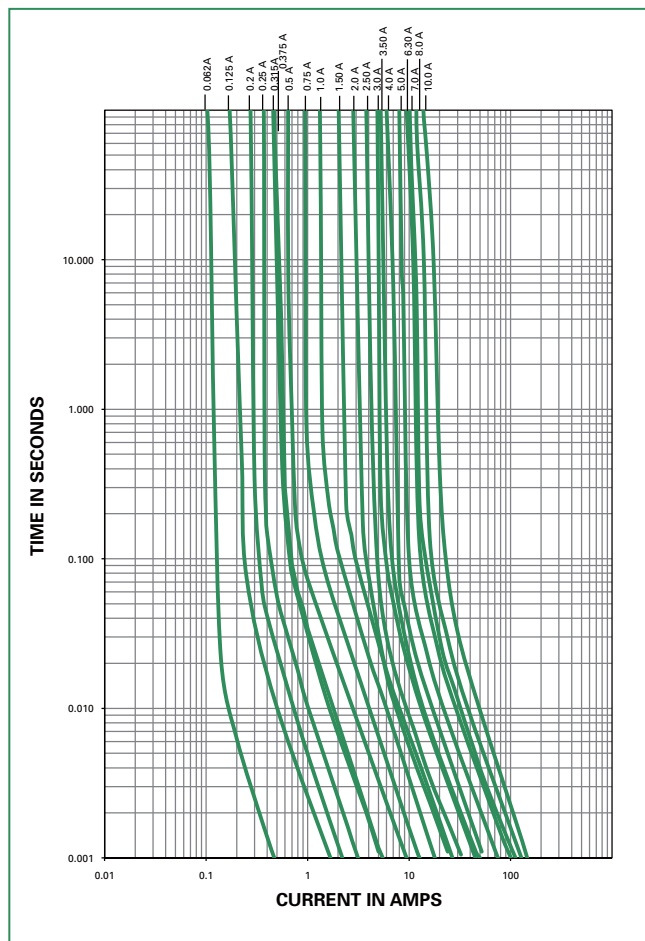

Soldering Parameters

Reflow Condition		Pb – Free assembly
Pre Heat	- Temperature Min ($T_{s(min)}$)	150°C
	- Temperature Max ($T_{s(max)}$)	200°C
	- Time (Min to Max) (t_s)	60 – 120 secs
Average ramp up rate (Liquidus Temp (T_L) to peak)		5°C/second max.
$T_{s(max)}$ to T_L - Ramp-up Rate		5°C/second max.
Reflow	- Temperature (T_L) (Liquidus)	217°C
	- Temperature (t_L)	60 – 90 seconds
Peak Temperature (T_p)		250 ^{+0/-5} °C
Time within 5°C of actual peak Temperature (t_p)		20 – 40 seconds
Ramp-down Rate		5°C/second max.
Time 25°C to peak Temperature (T_p)		8 minutes max.
Do not exceed		260°C

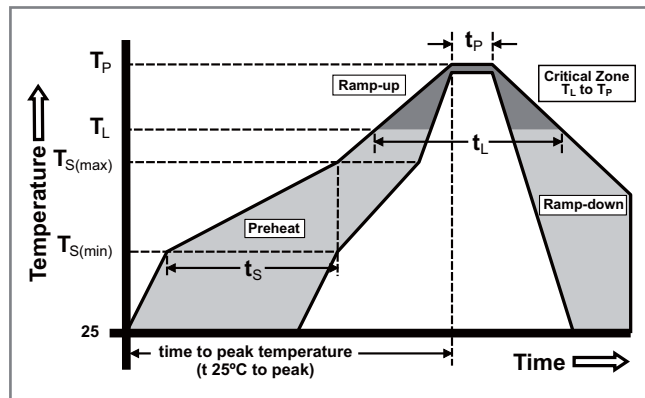

Product Characteristics

Materials	Body: Ceramic Cap: For 0.062A ~ 0.125A – Au plated Brass For 0.200A ~ 10A – Silver plated Brass Clip Plating: Matte Tin
Product Marking	Body: Brand Logo, Current Rating
Clip Retention	Force applied at fuse center, perpendicular to the long axis (@ 0.75 lbs. MIN)
Solderability	MIL-STD-202, Method 208 / IPC/ EIA / JEDEC J-STD002B, Test Condition A
Humidity Test	MIL –STD-202, Method 103 @ 85°C / 85%RH, 1000 hours
Resistance to Solvents	MIL-STD-202, Method 215 (3 solvent types)

Operating Temperature	-55°C to 125°C with proper derating
Thermal Shock	MIL-STD-202, Method 107, Test Condition B (5 cycles -65°C to +125°C)
Vibration	MIL-STD-202, Method 201 (10-55 Hz)
Moisture Resistance	MIL-STD-202, Method 106, 10 cycles
Salt Spray/ Atmosphere	MIL-STD-202, Method 101, Test Condition B (48 hrs.), 5% NaCl in De-ionized Water
Shock	MIL-STD-202, Method 213, Test Condition I (100 G's peak for 6 milliseconds)

Dimensions

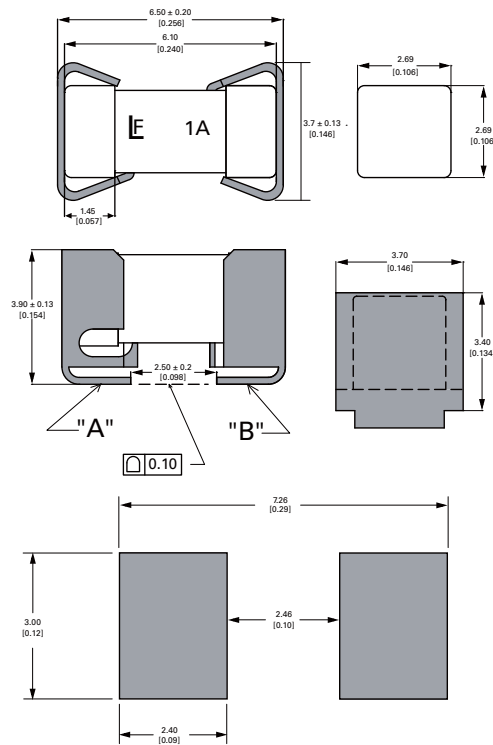

PCB Recommendation for Thermal Management

1. Minimum Copper Layer Thickness = 100µm
2. Minimum Copper Trace Width = 10mm

Note:

Alternate methods of thermal management may be used. In such cases, under normal operations, the maximum temperature of the fuse body should not exceed 80°C in a 25°C ambient environment.

Part Numbering System

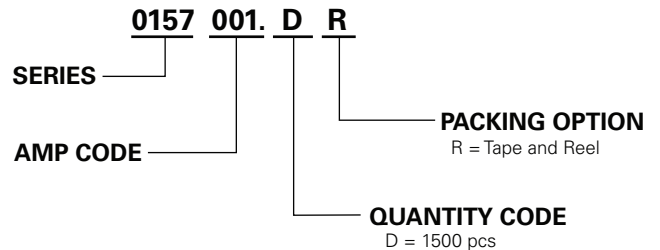

Packaging

Packaging Option	Packaging Specification	Quantity	Quantity & Packaging Code
Tape and Reel	Surface Mount	1500	DR

